

G 2000 MK

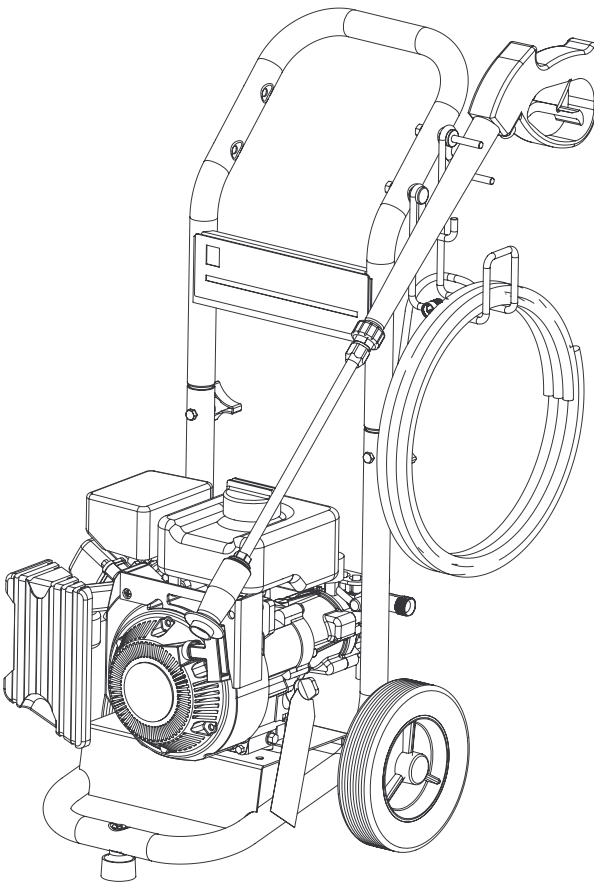

HIGH PRESSURE WASHER OPERATOR MANUAL

Model Overview	3
Important Safety Instructions	4
Assembly Instructions	6
Operating Instructions	6
Using the Accessories	9
Working with Detergents	9
Taking a Break	10
Shutting Down & Clean-Up	10
Winterizing and Long-Term Storage	10
Maintenance Instructions	11
Cleaning Tips	13
Troubleshooting	15

Specifications

Operating pressure	2000 PSI
Water volume	2.0 GPM
Detergent suction	0.15 - 0.20 GPM
Engine	87cc Grow A154 F
Part No.	1.133-621.0
Serial no.	

Safety Alert Symbols

DANGER

indicates “an imminently hazardous situation which, if not avoided, will result in death or serious injury.”

WARNING

indicates “a potentially hazardous situation which, if not avoided, could result in death or injury.”

CAUTION

indicates “a potentially hazardous situation which, if not avoided, may result in minor or moderate injury or in property damage incidents.”

Owner/User Responsibility

The owner and/or user must have an understanding of the manufacturer's operating instructions and warnings before using this pressure washer.

Warning information should be emphasized and understood.

If the operator is not fluent in English, the manufacturer's instructions and warnings shall be read to and discussed with the operator in the operator's native language by the purchaser/owner, making sure that the operator comprehends its contents.

Owner and/or user must study and maintain for future reference the manufacturers' instructions.

Kärcher Customer Support USA

Call: **1-800-537-4129** for help or visit our website:

www.karcher-usa.com/home

Please take a moment to register your pressure washer online at

www.karcher-usa.com/warranty

Kärcher Customer Service CDN

Call: **1-800-537-4129** for help or visit our website:

www.karcher-canada.com

Kärcher Customer Support Mexico

Call: **01-800-024-13-13** for help or visit our website: **www.karcher.com.mx**

MODEL OVERVIEW

- | | | | |
|---|--|----|------------------------------------|
| 1 | Handle | 8 | Spark plug
(not shown) |
| 2 | High pressure hose | 9 | Detergent suction tube with filter |
| 3 | Spray wand | 10 | High pressure outlet |
| 4 | Gas tank | 11 | Dipstick |
| 5 | Choke
(not shown) | 12 | Trigger gun |
| 6 | Water inlet filter | 13 | Trigger gun safety lock |
| 7 | Water inlet with garden hose connector | 14 | Gun/hose storage hanger |

For engine details see engine manual.

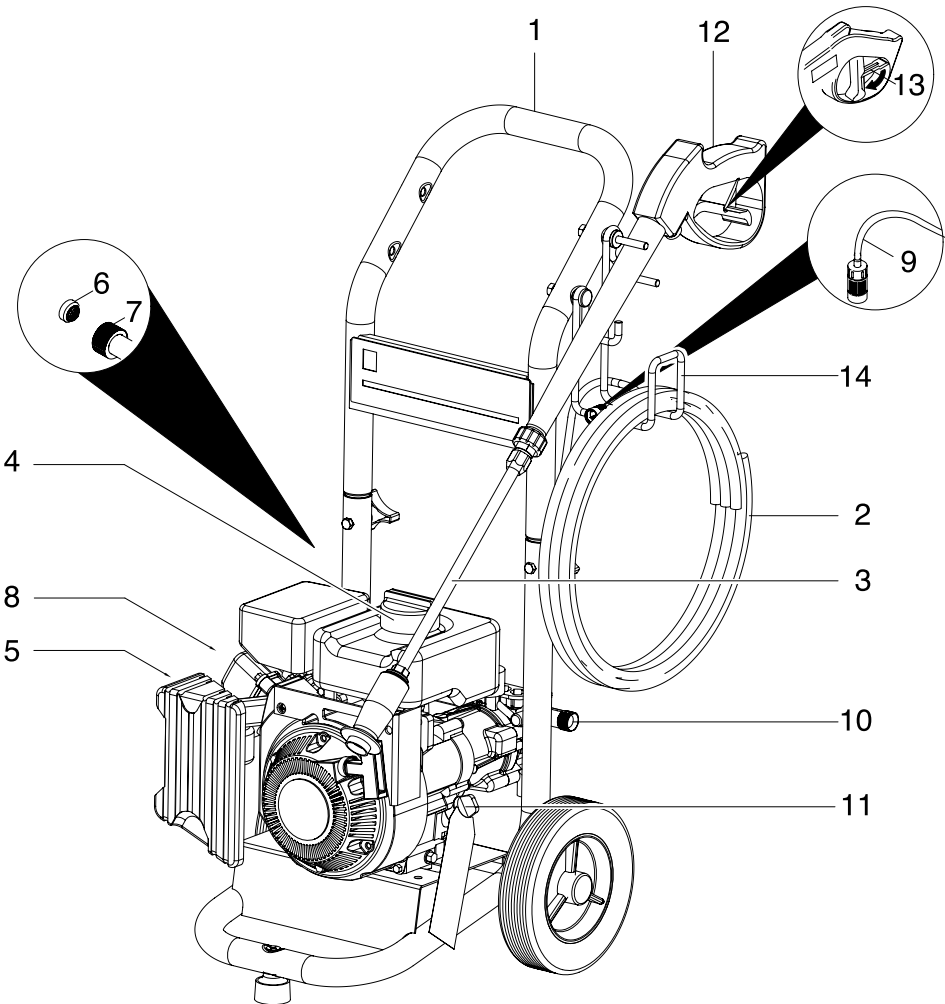

IMPORTANT SAFETY INSTRUCTIONS

- *Read the operating instructions of the engine manufacturer before start-up and follow the safety instructions carefully.*

⚠ WARNING

When using this product basic precautions should always be followed, including the following:

- *Read all the instructions before using the product.*
- *To reduce the risk of injury, close supervision is necessary when a product is used near children.*
- *Know how to stop the product and bleed pressures quickly. Be thoroughly familiar with the controls.*
- *Stay alert – watch what you are doing.*
- *Do not operate the product when fatigued or under the influence of alcohol or drugs.*
- *Keep operating area clear of all persons.*
- *Do not overreach or stand on unstable support. Keep good footing and balance at all times.*
- *Wear safety goggles.*
- *Follow the maintenance instructions specified in the manual.*

⚠ WARNING

Risk of Injection or Injury – Do Not Direct Discharge Stream At Persons.

- *High pressure jets can be dangerous if misused. The jet must not be directed at persons, animals, electrical devices, or the unit itself.*
- *Do not spray electrical connections, electrical outlets or fixtures.*

⚠ WARNING

Risk Of Explosion – Do not spray flammable liquids.

- *Do not use acids, alkaline, solvents, or any flammable material in this product. These products can cause physical in-*

juries to the operator and irreversible damage to the machine.

⚠ WARNING

Gun Kicks Back – Hold with both hands.

- *The Trigger Gun Safety Lock prevents the trigger from accidentally being engaged. This safety feature DOES NOT lock trigger in the ON position.*

⚠ CAUTION

Risk of Asphyxiation – Use this product only in a well ventilated area.

- *Operate and fuel machine in a well ventilated area, free of devices featuring an open pilot or flame such as boilers, water heaters, etc.*

⚠ CAUTION

Risk of Fire – Do not add fuel when the product is operating.

- *Do not operate if fuel has been spilled. Instead, move the machine to a different location and avoid creating sparks.*
- *Do not remove the gas tank cap or add fuel while the engine is running or hot. Add fuel after the engine has cooled by waiting 2 or more minutes after the engine is stopped.*
- *Do not smoke when adding fuel*
- *Do not allow the high pressure hose to come into contact with the muffler guard.*
- *Do not leave the machine running unattended.*
- *Avoid tipping the machine on its side.*
- *Do not operate the machine with the muffler or the air cleaner removed. Especially for the muffler, check the tightness of mounting screw, damage and leakage periodically, and if abnormality is found, repair or replace it.*
- *Occasionally inspect the fuel system components to check for cracks and leaks. Replace components when necessary.*

⚠ WARNING

- Do not check for spark with the spark plug removed.
- Do not touch the high-voltage cord or spark plug cap.
- Do not stop the machine by using the choke lever.
- Do not unreasonably adjust the engine speed.
- Do not place hands or feet near moving or rotating parts.
- Do not operate machine with combustible material in the muffler area.

⚠ CAUTION

- Do not touch hot surfaces or allow accessories to contact hot surfaces.
- The machine has hot surfaces which can cause burns. Operate the unit in a safe environment and away from children.
- Remove trash, grass and other debris from around the cooling fins and recoil starter.
- Always use new gasoline. Old gasoline could cause build up in the carburetor

which could cause poor engine operation.

SAVE THESE INSTRUCTIONS

WATER SUPPLY (Cold Water Only)

⚠ CAUTION

*When connecting the water inlet to the water supply mains, local regulations of your water company must be observed. In some areas the unit must not be connected directly to the public drinking water supply. This is to ensure that there is no feedback of chemicals into the water supply. Direct connection via a receiver tank or backflow preventer, for example, is permitted.
Dirt in the feed water will damage the unit. To avoid this risk, we recommend fitting a water filter.*

- Garden hose must be at least 5/8 inch in diameter.

- Flow rate of water supply must not fall below 2.8 GPM (gallons per minute).
- Flow rate can be determined by running the water for one minute into an empty 5-gallon container.
- The water supply temperature must not exceed 104°F/40°C.
- Never use the pressure washer to draw in water contaminated with solvents, e.g. paint thinners, gasoline, oil, etc.
- Always prevent debris from being drawn into the unit by using a clean water source. Use additional water filter.
- Do not operate pressure washer without the water turned on.

ASSEMBLY INSTRUCTIONS

→ STEP 1:

Attach the handle to the frame of the pressure washer. Align holes, insert bolts, and tighten with knobs.

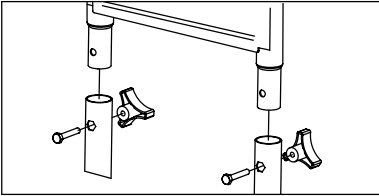

→ STEP 2:

Mount the gun/hose storage hanger.

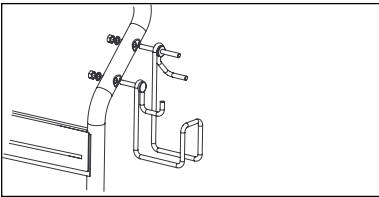

→ STEP 3:

Attach the high pressure hose to the spray gun.

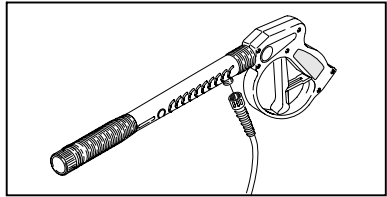

→ STEP 4:

Attach the wand to the spray gun.

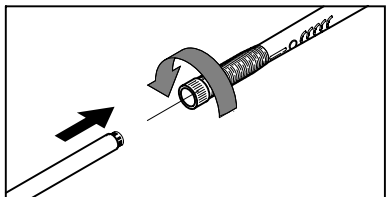

OPERATING INSTRUCTIONS

Please follow the instructions step-by-step. Failure to follow the instructions explicitly could lead to premature failure of the engine.

⚠ CAUTION

Engine shipped without oil. Before starting engine, fill with oil. Do not over-fill. Do not run the engine with a high or low oil level as this can cause engine damage.

→ STEP 1:

Add the oil (1 bottle of SAE 15W 40SF/ SJ) supplied with your pressure washer to the engine crankcase only. Failure to add engine oil will cause engine failure. This type of failure is not covered by the manufacturer's warranty.

Oil amount should not exceed 10 oz / 300ml.

Below indicates the optimal levels when adding or checking oil.

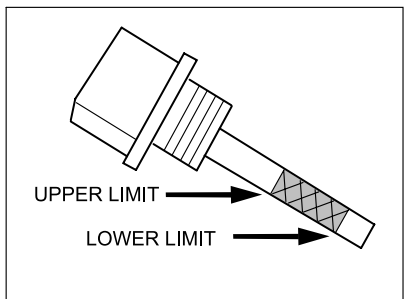
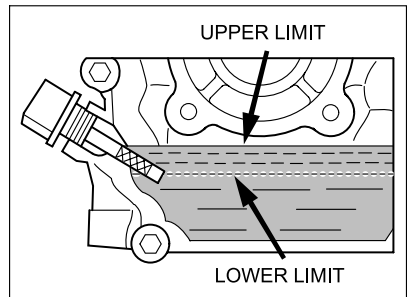

⚠ CAUTION

Too much oil can cause the engine to overheat. Signs include but are not limited to the following: a decrease in engine performance, oil leaking from the governor arm, an oil seal, or the air filter.

To correct this, immediately drain the oil from the engine and make sure you are using the correct amount of oil as shown previously.

→ STEP 2:

Before starting the engine, **move the CHOKE lever to the CHOKE position as indicated.**

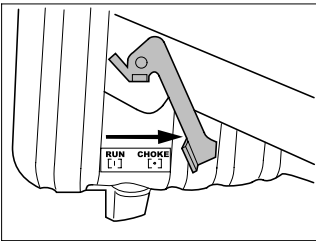

After engine has warmed and idles smoothly, **move CHOKE lever to the RUN position as indicated.**

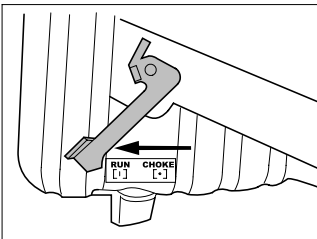

Warm engine starting:

Move the CHOKE lever to the CHOKE position as indicated in the previous step. Once you have achieved stable idle, move CHOKE lever back to RUN position.

→ STEP 3:

Connect the high pressure hose to the unit's high pressure outlet.

→ STEP 4:

Connect garden hose to unit's water inlet.

→ STEP 5:

Connect garden hose to the cold water source and turn water on completely. Do not use hot water.

→ STEP 6:

If the trigger gun safety lock is engaged, please disengage.

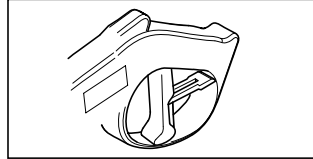

Hold the trigger gun open until all trapped air is eliminated from the low pressure water stream.

→ STEP 7:

Check oil level.

Please see **STEP1** for details on min/ max levels

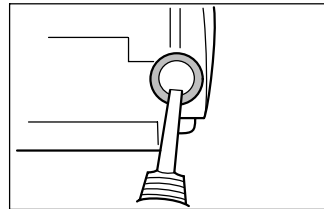

→ STEP 8:

Fill gas tank with unleaded gasoline.

Do not use leaded gasoline.

Do not mix oil into the gasoline.

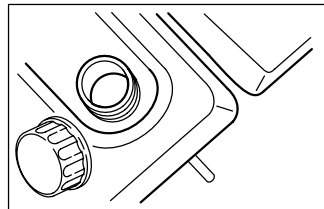

→ **STEP 9:**

Push the engine switch to the ON position.

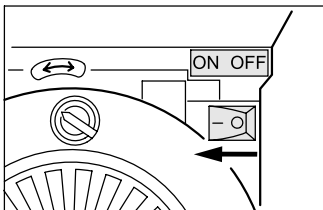

→ **STEP 10:**

Open fuel valve.

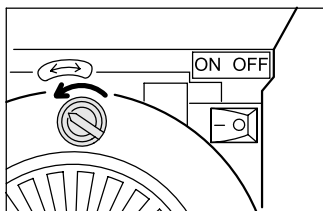

→ **STEP 11:**

Set CHOKE lever to the CHOKE position.

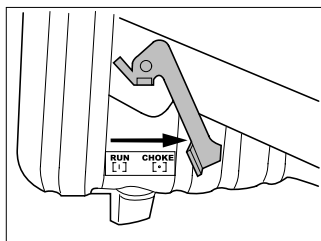

→ **STEP 12:**

Pull the starter handle.

If the engine fails to start after 3 pulls, squeeze the trigger gun to release pressure, and repeat step.

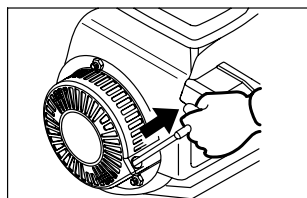

→ **STEP 13:**

Move back the CHOKE lever to the RUN position as indicated.

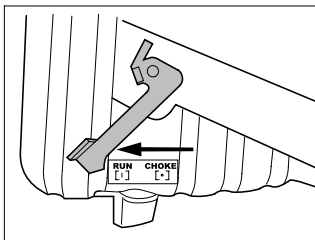

NOTE:

- Always check engine oil and gasoline before operating your pressure washer.
- Do NOT overfill engine oil
- Move CHOKE lever to the RUN position once the engine runs warm and stable.
- A WARM start require the CHOKE lever to be in the CHOKE position.

USING THE ACCESSORIES

High / Low pressure nozzle

This nozzle features four positions. The high setting (+) provides a steady powerful high pressure spray pattern, for general cleaning. The low setting (-) creates a low pressure spray pattern.

Note: Detergent is applied with the nozzle set at low pressure.

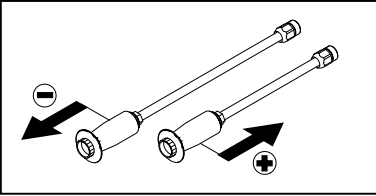

After pulling backwards to high pressure, turn wand left or right to change the spray pattern between point jet and flat jet.

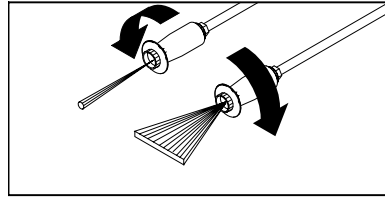

⚠ WARNING

To avoid serious injury never point spray nozzle at yourself, other persons or animals.

WORKING WITH DETERGENTS

→ STEP 1:

Slide spray wand tip to low pressure position.

→ STEP 2:

Fill a container with Kärcher detergent. Place the filter end of detergent suction tube into the container.

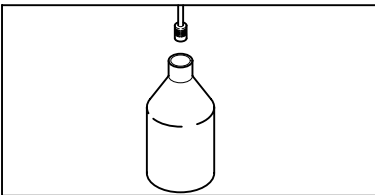

→ STEP 3:

With the engine running, pull trigger to operate unit.

Liquid detergent is drawn into the unit and mixed with water.

Apply detergent to work area.

Do not allow detergent to dry on surface.

→ STEP 4:

Always draw fresh water through the detergent suction tube when the cleaning job is done, to rinse/flush any remaining detergents from the injection system.

For best results see Cleaning Tips for specific information on how to clean different surfaces.

Detergents

⚠ CAUTION

This unit has been designed for use with cleaning detergents recommended by the manufacturer. The use of other cleaning detergents may affect the operation of the machine and void the warranty.

Always Use Kärcher Detergent for Best Results

Kärcher biodegradable detergents are specially formulated to protect the environment and your pressure washer. The special formula won't clog the suction tube filter and will protect the internal parts of the pressure washer for a longer life. For Kärcher Deter-

gents, check your retailer or visit our website:

www.karcher-usa.com/home

Kärcher detergents available in USA / Mexico:

- All Purpose & Vehicle Cleaner
- Exterior House Cleaner
- Deck & Patio Cleaner
- Heavy Duty Degreaser

Kärcher detergents available in Canada:

- Vehicle Wash
- Pressure Wash
- Deck & Fence Wash

- Degreaser

⚠ CAUTION

Never use:

- Bleach, Chlorine products and other corrosive chemicals
- Liquids containing solvents (i.e., paint thinners, gasoline, oils)
- Tri-sodium phosphate products
- Ammonia products
- Acid-based products

These chemicals will harm the unit and will damage the surface being cleaned.

Use of these items will void the warranty.

TAKING A BREAK ..five minutes or more

→ STEP 1:

Push the engine switch to the OFF position.

→ STEP 2:

Release trigger and engage gun safety lock.

SHUTTING DOWN & CLEAN-UP

→ STEP 1:

Remove detergent suction tube from container and insert into 1 gallon of fresh water.

Siphon water at low pressure for one minute.

→ STEP 2:

Push the engine switch to the OFF position.

→ STEP 3:

Close the fuel valve.

→ STEP 4:

Turn off the water source.

→ STEP 5:

Press trigger to release water pressure.

→ STEP 6:

Release trigger and engage gun safety lock.

→ STEP 7:

Disconnect the garden hose from the water inlet on the unit.

→ STEP 8:

Disconnect the high pressure hose from the high pressure outlet.

WINTERIZING AND LONG-TERM STORAGE

→ 1: Disconnect all water connections.

→ 2: Turn on the machine for a few seconds, until the water which had remained in the pump exits, turn off immediately.

→ 3: Do not allow high pressure hose to become kinked.

→ 4: Store the machine and accessories in a room which does not reach freezing temperatures. DO NOT store near fur-

nace or other sources of heat as it may dry out the pump seals.

⚠ CAUTION

Failure to follow the above directions will result in damage to the pump assembly and accessories and will void the warranty.

Kärcher also recommends the regular practice of using a pump protector like "Kärcher Pump Guard" to prevent cold weather damage during storage in the winter months.

MAINTENANCE INSTRUCTIONS

Kärcher pump

Initial Use

All Kärcher pumps ship with oil already inside direct from the factory. There is no need to add oil.

Pump Inspection

You should routinely make a visual inspection of the pressure washer's pump. If you notice oil leaking around the pump seals, you should take the pressure washer to a

Kärcher-Authorized Service Center for repair. (You can locate a service center in your area online at www.karcher-usa.com/service.)

Pump Maintenance

The pump on your Kärcher pressure washer does not require maintenance. Any attempts to service or alter the pump may damage your pressure washer and void your product warranty.

Engine

Change the oil within the first 20 hours. Subsequent oil changes should be every 40 hours.

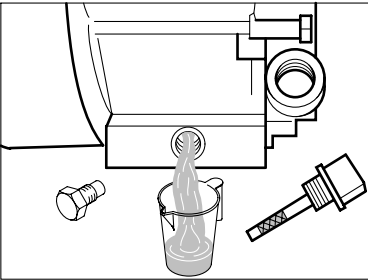

Clean the air filter every 40 hours.

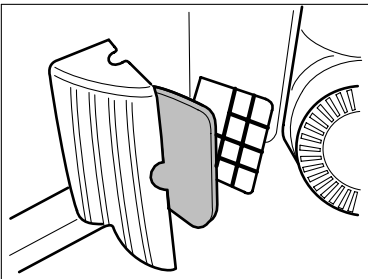

Regular inspection table:

	Before every use	Every 20 hours	Every 40 hours	Every 100 hours
Inspection and tightening of bolts and nuts.	x			
Check engine oil and add if necessary.	x			
Change of engine oil		only first time	x	
Check for fuel and oil leaks.	x			
Check and cleaning of air filter	x			
Clean around the recoil starter	x			
Clean the muffler cover.	x			
Check and clean the spark plug.			x	
Removal of carbon in combustion chamber.				by distributor only
Check and adjustment of valve clearance.				by distributor only
Replace the fuel lines.	3 years (or when necessary)			

CLEANING TIPS

Deck Cleaning

(with or without detergent). Pre-rinse deck and surrounding area with fresh water. If using Kärcher Deck Wash, apply to surface at low pressure. For best results, limit your work area to smaller sections of approximately 25 square feet. Allow Deck Wash to remain on surface 1-3 minutes. Do not allow detergent to dry on surface. Rinse at high pressure in a long sweeping motion keeping the spray nozzle approximately 3-6 inches from the cleaning surface. Always clean from top to bottom and from left to right. When moving on to a new section of the cleaning surface, be sure to overlap the previous section to eliminate stop marks and ensure a more even cleaning result.

⚠ CAUTION

Do not use Dirtblaster spray nozzle on wood surface as it may cause damage.

House Siding

(with or without detergent). Pre-rinse cleaning surface with fresh water. If using Kärcher Pressure Wash, apply to surface at low pressure (for best results, limit your work area to sections of approximately 6 feet and always apply detergent from bottom to top). Allow Pressure Wash to remain on surface 1-3 minutes. Do not allow detergent to dry on surface, if surface appears to be drying, simply wet down surface with fresh water. If needed, use special wash brush attachment (not included) to remove stubborn dirt. Rinse at high pressure from top to bottom in an even sweeping motion keeping the spray nozzle approximately 6 inches from the cleaning surface.

⚠ CAUTION

Do not use Dirtblaster spray nozzle on siding as it may cause damage.

Cement Patios, Brick and Stone

(with or without detergent). Pre-rinse cleaning surface with fresh water. If using Kärcher Pressure Wash or Degreaser, apply to surface at low pressure. For best results, limit your work area to smaller sections of approximately 25 square feet. Allow Pressure Wash or Degreaser to remain on surface 1-3 minutes. Do not allow detergent to dry on surface. Rinse at high pressure in a sweeping motion keeping the spray nozzle approximately 3-6 inches from the cleaning surface. Always clean from top to bottom and from left to right. For removing extremely stubborn stains, use the Dirtblaster Nozzle.

Cars, Boats & Motorcycles

(with or without detergent). Pre-rinse vehicle with fresh water. If using Kärcher Touchless Vehicle Wash, apply to surface at low pressure. For best results, clean one side of vehicle at a time and always apply detergent from bottom to top, do not allow detergent to dry on surface. If needed, use special wash brush attachment (not included) to remove stubborn dirt. Rinse at high pressure in a sweeping motion keeping the spray nozzle approximately 6-8 inches from the cleaning surface (distance should increase when rinsing pin-striping or other sensitive surfaces). Always clean from top to bottom and from left to right. For best results, wipe surface dry with a chamois or soft dry cloth.

⚠ CAUTION

Do not use Dirtblaster spray nozzle on vehicles as it may cause damage.

Barbecue Grills, Outdoor Power Equipment & Gardening Tools

(with or without detergent). Pre-rinse cleaning surface with fresh water. If using Kärcher Pressure Wash or Degreaser, apply detergent at low pressure. Allow Pressure Wash to remain on surface 1-3 minutes. Do not allow detergent to dry on surface. Rinse at high pressure keeping the spray nozzle approximately 3-6 inches from the cleaning surface. For removing extremely stubborn dirt, it may be necessary to move the spray nozzle even closer to the surface for greater dirt cutting action.

CAUTION

Do not use Dirtblaster spray nozzle on cloth, plastic or other sensitive surfaces as it may cause damage.

Patio & Lawn Furniture

(with or without detergent). Pre-rinse furniture and surrounding area with fresh water. If using Pressure Wash, apply to surface at low pressure. Allow Pressure Wash to remain on surface 1-3 minutes. Do not allow detergent to dry on surface. If needed use special Wash Brush Attachment (not included) to remove stubborn dirt. Rinse at high pressure in a sweeping motion keeping the spray nozzle approximately 3-6 inches from the cleaning surface. For best results, clean from top to bottom and from left to right.

CAUTION

Do not use Dirtblaster spray nozzle on patio or lawn furniture as it may cause damage.

Recommendations

- Before cleaning any surface an inconspicuous area should be cleaned to test spray pattern and distance for maximum cleaning results.
- If painted surfaces are peeling or chipping, use extreme caution as pressure washer may remove the loose paint from the surface.
- When using on surfaces which might come in contact with food, flush surfaces with plenty of drinking water.
- For additional cleaning tips, visit our website at www.karcher-usa.com/home

Optional Accessories

Optional accessories are available to further enhance your cleaning capabilities. Please check our website www.karcher-usa.com/home for pricing and up-to-date information.

TROUBLESHOOTING

⚠ CAUTION

Remove the spark plug cable to prevent accidental ignition of the engine before making any repair.

Symptom	Cause	Solution
Engine will not start	No gasoline	Fill gas tank
	Engine switch is in the OFF position.	Push the engine switch to the ON position.
	Fuel valve is closed	Open fuel valve.
	Water pressure built up in the machine.	Squeeze the trigger to release the pressure.
Unit does not reach high pressure.	Diameter of garden hose is too small.	Replace with a 5/8 inch or larger garden hose.
	Water supply is restricted.	Check garden hose for kinks, leaks and blockage.
	Not enough inlet water supply.	Turn water on full force. Check garden hose for kinks, leaks or blockage.
	Water inlet filter is clogged.	Remove filter and rinse out in warm water.
	Spray wand is on low pressure position.	Slide spray wand tip to low pressure position.
Output pressure varies high and low.	Not enough inlet water supply.	Turn water on full force. Check garden hose for kinks, leaks or blockage.
	Pump is sucking air.	Check that hoses and fittings are air tight. Turn off machine and purge pump by squeezing trigger gun until a steady flow of water emerges through the nozzle.
	Water inlet filter is clogged.	Remove filter and rinse out in warm water.
	Spray nozzle is obstructed.	Blow out or remove debris with a fine needle.
	Calcified gun, hose or spray wand.	Run distilled vinegar through detergent suction tube.

Symptom	Cause	Solution
No detergent.	Detergent suction tube not properly connected to the machine.	Check connection.
	Detergent is too thick.	Dilute detergent, for best results use Kärcher detergent.
	Filter on detergent suction tube is clogged.	Run warm water through filter to remove debris.
	Damaged or clogged detergent suction tube.	Remove obstruction or replace detergent suction tube.
	Spray nozzle is obstructed.	Blow out or remove debris with fine needle.
Garden hose connection leaks.	Loose fittings.	Tighten fittings.
	Missing/worn rubber washer.	Insert new washer.
Spray wand leaks.	Spray wand not properly attached.	Turn the swivel nut of the gun clockwise until connection is tight.
	Broken o-ring or plastic insert.	Call Customer Support
Pump is noisy.	Pump is sucking air.	Check that hoses and fittings are air tight. Turn off machine and purge pump by squeezing trigger gun until a steady flow of water emerges through the nozzle.
Water leaks from pump (up to 10 drops per minute is permissible).	Loose fittings.	Tighten fittings.
	Water seals are damaged or worn.	Call Customer Support
Oil Drip.	Oil seals are damaged or worn.	Call Customer Support

If you encounter any additional difficulties not listed, please call for help or visit our website.

USA: 1-800-537-4129

www.karcher-usa.com/home

Canada: 1-800-537-4129

www.karcher-canada.com

Mexico: 01-800-024-13-13

www.karcher.com.mx