

OPERATORS MANUAL

SH Series



Q Series



TR Series



Images, from left, illustrate SH-style, Q-style, and TR-style pressure washers.

<input type="checkbox"/>	<u>Model</u>	<u>PSI</u>	<u>GPM</u>	<u>Horsepower</u>	<u>Fuel type</u>	<u>Weight ship/net (lb)</u>
<input type="checkbox"/>	1700SHDR	1700	3.0	6.0 Robin	For all:	380
<input type="checkbox"/>	25006QD	2500	3.0	6.5 Diesel		380
<input type="checkbox"/>	3000QB	3000	4.0	13.0 Vanguard	No. 1 diesel,	570
<input type="checkbox"/>	3000QD	3000	4.0	10.0 Diesel		570
<input type="checkbox"/>	3000QH	3000	4.0	13.0 Honda	No. 2 diesel,	570
<input type="checkbox"/>	4000QB	4000	4.0	16.0 Vanguard		600
<input type="checkbox"/>	2000TRDH	2000	4.0	11.0 Honda		600
<input type="checkbox"/>	3000TRDH	3000	4.0	13.0 Honda	or	600
<input type="checkbox"/>	3000TRDB	3000	4.0	13.0 Vanguard		600
<input type="checkbox"/>	4000TRDB	4000	4.0	16.0 Vanguard	kerosene	600

Cam Spray Hot Water Models

Gas-powered, diesel-fired hot water power washers
Manual Version 082501

Cam Spray
520 Brooks Road
Iowa Falls, IA 50126

toll free: 1.800.648.6007
fax: 1.641.648.5013

e-mail: camspray@camspray.com



Working well under pressure!

Thank you

Thank you for selecting our products. Our personnel have proudly made every effort to ensure that your new pressure washer is of the quality you expect. But things do occasionally go wrong. This is why every pressure washer is covered by a limited warranty. Among other things, this warranty provides for the replacement of parts found to be defective during the operation of your new pressure washer. Please note that the owner/operator has certain obligations under the terms of the warranty. Be sure to read this manual for directions on proper installation, start-up, use, and storage of your pressure washer.

Your new pressure washer was tested after production for proper pressure and flow. Please note that this process will sometimes leave a water residue in the pump. The dealer you have purchased your new machine from should review with you the proper installation, start-up, use, and storage. Most 'big' problems occur when shortcuts are taken in one of these processes. If a problem occurs that you need some assistance with, please feel free to contact us at the listing below: Be familiar with the model plate located on your machine.

Warranty Service Center
520 Brooks Road
Iowa Falls, IA 50126
1.800.648.6007

Please make note of Model Identification	
Model	_____
Code	_____
Serial #	_____
Always have this information when calling Warranty Service Center.	

Statement of warranty

The manufacturer of this pressure washer agrees to repair or replace designated parts that prove defective within one year from date of original purchase. Specific limitations and exclusions apply. To make claim under the terms of the warranty, all parts said to be defective must be returned to the Warranty Service Center listed above for warranty inspection. The judgments and decisions of the factory personnel concerning the validity of warranty claims are final.

Items not covered by the warranty given by us include motors, engines, and pumps. These components are covered by warranties given by their respective manufacturers. These warranties pass through to the end user. As a factory authorized and trained warranty service center, the factory will honor the terms of all component warranties and satisfy claims of the appropriate warranty provisions.

Normal wear items are not covered by this warranty. Normal wear items include hoses, nozzles, filters, valves, and seals.

This warranty does not cover the following: machines used for rental purposes, damage resulting from shipping, accident, abuse, misuse, or neglect. Also not covered is damage from repairs or alterations performed by non-factory authorized personnel or failure to install and operate equipment according to the guidelines put forth in the instruction manual.

The manufacturer will not be liable to any persons for consequential damage, for personal injury, or for commercial loss.

 WARNING
Engine exhaust from this product contains chemicals known to the State of California to cause cancer, birth defects, or other reproductive harm.



WARNING

The following warnings must be followed. Failure to follow these warnings could result in serious personal injury or death!

Never allow children or untrained personnel to operate machinery.

Gun kicks back--hold with both hands.



Electrical equipment can cause shock and sparks.

Do not bypass or remove the grounding prong in any electrical plug.

Keep electrical plugs, connections, and cords out of water and moisture.

Disconnect from power source before servicing.

Inspect and repair damaged or exposed electrical components prior to use.

Never splice electrical cords on pressure washers.

Be sure electrical service is adequately sized for the equipment.



Exhaust fumes contain harmful gasses.

Exhaust gasses can cause death or serious injury.

Use only in well ventilated areas or vent the exhaust to the outside.



High pressure water can cause death or serious injury.

Warning--high temperature water.

Wear protective clothing and face shield.

Do not direct water stream toward self or others.

All hoses should be secured in the lines to be cleaned at least five feet.

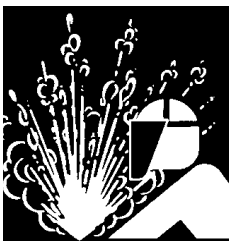

Pressurized fluid streams and ruptured pressure vessels can cause death or serious injury.

High pressure fluid can create a high pressure stream or ruptured vessel.

Wear a safety face shield.

Relieve pressure before servicing.

Do not modify, repair, or rework vessel or change safety relief or pressure setting.

Do not direct stream toward self or others.

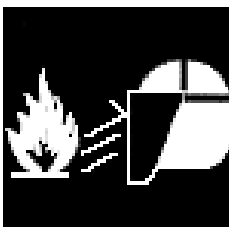

Fire can cause death or serious injury.

Kerosene, fuel oil, and gasoline will burn when ignited.

Wear face shield and protective clothing.

Do not expose fuel to flames, sparks, or other sources of ignition.

Use in well ventilated area or vent to outside area.

Save these instructions

Initial setup and operation of your new pressure washer

- Inspection for freight damage When you receive your pressure washer, be sure you check for concealed freight damage. Any damage should be noted with the delivering carrier. If you have any questions related to freight, call the 800 number listed in the front of the manual.
- Inspection of oil levels Check all oil levels in the pump or engine, if applicable. Failure to check all levels will result in equipment damage. Most pumps are shipped with oil from factory and the crankcase are sealed, you may have to remove a shipping plug and install a dipstick in the pump. Most engines are shipped *without oil*, be sure to check these oil levels.
- Water supply Your water supply must provide water to the equipment that exceeds the Gallon Per Minute (GPM) rate of your machine. You can check your GPM by using a five gallon bucket and a timer. If your machine is five GPM or less and the bucket fills in less than a minute you have adequate supply. Some systems are effected by things like washing machines, livestock watering systems, and flushing toilets. Be sure the supply is still adequate when these operations are taking place. The water temperature cannot exceed 145 degrees Fahrenheit. Water pressure should not exceed 60 PSI. Failure to secure adequate water supply will result in pump damage. Do not run pump dry.
- Water quality Your water should not contain particles larger than 80 microns. Although there are small filters installed on pressure washers that filter the water, they can only filter poor quality water for a short period of time before they clog. Clogging would result in damage to the machine. Therefore you should insure no sand or scale particles are present in the water supply.
- Supply hose Hook a garden hose from the hydrant to the machine, when doing this be sure to check the inlet water filter or screen. This hose should be at least 5/8' diameter and a length at least 15 feet. This 15 foot length helps isolate the water supply from pulsations from the pump. Many states require a Vacuum Break or backflow preventer be installed at the hydrant, before the garden hose, to insure the water source cannot be contaminated. Be sure to check local and state regulations upon installation.
- Purge air Turn on the water supply and open the trigger gun, this will purge all the air from the system. Look for water leaks and stop any leak found. Leaks can cause erratic pump behavior.
- Burner fuel Turn equipment off and allow time to cool before refueling. Fill the burner tank labeled 'fuel'. Be sure the fuel is clean and free from moisture and particles. Use only No. 1, No. 2 or kerosene, no other fuel should be used! There is a fuel filter in the line. Check this filter prior to operation. Do not run fuel pump dry, doing so will damage the fuel pump.
- Pump/engine Prior to starting the engine, check the oil in the engine and pump. Be sure they are at proper operating levels and that the correct oil for the conditions is being used. Check your engine manual for oil type and conditions and the pump breakdown for proper oil for the pump.
- Fuel Be sure your engine is full of fresh, clean fuel.
- Starting engine Start your engine following the instructions in the engine manual. Be familiar with fuel shutoff, throttle control, choke, and shutoff switch before starting. Allow engine to warm at half throttle for one to two minutes before operating washer. Run engine at half throttle for one to two minutes before shutting down.

Initial setup and operation of your new pressure washer, cont.

- During operation** The pressure was set at the factory during the testing procedure, no adjustments to the machine should be required for operation. During operation the burner may cycle on and off. The adjustable thermostat may be set to desired temperature. Water temperature will not exceed 190 degrees, the safety switches will shut the burner down. During operation do not leave the machine running for more than two minutes without the trigger gun being pulled. Although your machine has a by-pass valve on it and may have a thermal relief system, this can cause extensive pump damage. If machine will not be discharging water for more than two minutes, shut the machine off.
- Interchangeable tips** Your machine is supplied with interchangeable spray tips. The colored tips are for high-pressure rinse at different spray angles. The red tip sprays at zero degrees; yellow, fifteen degrees; green, twenty-five degrees; and white, forty degrees. The yellow tip is used for most standard applications. Be sure the quick coupler is fully engaged before pulling the trigger gun. Failure to do so may result in the tip becoming a projectile and may be lost and damage to property and persons may occur.
- Chemical injector use** Your pressure washer is supplied with a downstream chemical injector. The 1/4" clear vinyl tube is to be inserted into the desired chemical to apply. Be sure the nozzle with the large hole, approximately 1/8", is used when desiring to inject chemical. The chemical injector will only open up and allow chemical into the line when this tip is used. This tip enables the pressure to drop to approximately 250 PSI to draw chemical. This is done by turning the side handle on the wand, this is a valve that allows the water to flow through the wand and through the chemical tip. The rate of injection can also be set by turning the knob that the clear vinyl tube attaches to. Be sure to flush injection system with clear water after use.
- Calibration** If an accurate injection rate is desired, use this formula.
(GPM x 128) / ounces drawn in one minute = x: 1
IE: If a 2.0 GPM machine draws eight ounces of chemical in one minute: $\frac{2 \times 128}{8} = 32:1$

Shut down procedure

- Storage**
1. Turn off the power switch on the burner. Continue to run the pressure washer and pull the trigger to circulate water through to cool the coil.
 2. After several minutes when water is cool, shut off the pressure washer motor or engine.
 3. Shut off water supply and disconnect garden hose.
 4. Be sure to double check for water leaks or oil leaks that should be repaired before the next operation.
- Winter storage** If you are going to store the machine for extended period of times in cold climates be sure to winterize the equipment. If you have a gas engine, be sure to treat the fuel for storage. A fifty percent anti-freeze solution may be drawn in through the inlet of the pump using a short remnant of garden hose. This fluid should be run through the pump and coil. When the fluid is discharged from the coil discharge your machine is winterized. Do not allow machine to freeze.
- Pump** The pump oil should be changed after the first fifty hours of operation, then every year for average service or more frequently for extensive use or hostile environments (dusty or high moisture).

Shut down procedure, cont.

Engine	Engine oil should be changed per the manufacturers recommendations. Refer to enclosed manufacturer's literature.
Filters	Water, oil, fuel filters, hoses and fittings should be checked prior to every operation for cleanliness, leaks and needed repair and replacement.

Troubleshooting: common problems and solutions

Despite the complexity of your power washing equipment, a number of common complaints stem from relatively simple problems. With guidance, the user can identify and remedy many common problems.

Always disconnect the power supply before attempting to service any equipment.

Malfunction	Cause	Remedy
Pressure washer will not run	<ul style="list-style-type: none"> -Switch in 'off' position -Low oil level in engine -Circuit breaker tripped 	<ul style="list-style-type: none"> -Turn switch to 'on' position -Fill oil to proper level -Reset circuit breaker in main panel
Unit runs but no water discharges	<ul style="list-style-type: none"> -Water supply not turned on -Plugged nozzle on wand -Trigger gun off or malfunctioning 	<ul style="list-style-type: none"> -Turn on water supply -Remove, clean, or replace nozzle -Remove, repair, or replace trigger gun
Low nozzle pressure	<ul style="list-style-type: none"> -Plugged spray nozzle -Inlet screen is plugged -Insufficient water supply -Unloader valve stuck open -Plugged inlet or discharge hose -Use of additional lengths of hose -Soap control valve open 	<ul style="list-style-type: none"> -Remove nozzle and clean or replace -Remove filter and clean or replace -Secure adequate water supply -Disassemble and clean; repair or replace -Flush or replace hoses -Reduce discharge hose length. -Close valve (refer to pg 11 gun/wand breakdown)
Surging pressure or drop in pressure	<ul style="list-style-type: none"> -Partially plugged spray nozzle -Worn nozzle -Soap (low pressure tip installed) -Restricted or leaking water hose -Cavitation (inadequate water supply) -Worn pump packings -Fouled inlet or discharge valves -Broken valve spring -Worn or restricted unloader valve 	<ul style="list-style-type: none"> -Remove nozzle and replace or clean -Remove and replace nozzle -Remove and install one of the nozzles -Check inlet hose and filter; clean or replace -Secure adequate water supply -Inspect and replace worn packings -Inspect valves and clean or replace -Inspect and replace valve spring -Inspect unloader and repair or replace
Pressure at pump but low discharge pressure at gun	<ul style="list-style-type: none"> -Restricted discharge 	<ul style="list-style-type: none"> -Check for discharge obstructions in injector
Chemical injector not working properly	<ul style="list-style-type: none"> -Valve on gun/wand not open -Injector valve not turned on -Discharge hose too long -Clogged injector pick-up hose -Clogged injector 	<ul style="list-style-type: none"> -Open valve by turning forward handle counter-clockwise. (see wand breakdown page 10) -Turn on injector by turning fitting on injector -Reduce hose length or reposition injector to within forty feet of trigger gun -Remove and clean or replace -Disassemble, clean, and reassemble
Water leaks from pump manifold	<ul style="list-style-type: none"> -Worn plungers or packings 	<ul style="list-style-type: none"> -Inspect and replace

Troubleshooting: common problems and solutions, cont.

Malfunction	Cause	Remedy
Unloader cycles when gun is shut off	-Leak in trigger or discharge	-Inspect leaking fittings and repair or replace
Water in crankcase	-High humidity or direct water spray -Worn seals	-Reduce oil change intervals -Replace seals
Will not produce hot water	-Burner switch in 'off' position -Burner switch on but pump switch off -Inadequate fuel supply -Plugged fuel filter -Trigger gun not pulled on -Thermostat turned off	-Turn burner switch on -Turn on pump switch (must be on for heater to operate properly) -Fill tank with kerosene, no. 1 or no. 2 diesel -Replace fuel filter -Pull trigger gun (water flow must go through coil to operate heater) -Turn thermostat dial to the 'on' position

For problems beyond those listed, refer to flow chart included with the burner breakdown.

Burner troubleshooting

Pump is running
Burner is running
Burner will not fire

Check fuel supply

Tank empty →

Fill fuel tank

Tank full ↓

While machine is running, disconnect fuel line at burner housing. Is fuel flowing?

Yes ↓

Check transformer by arching an insulated handle across contacts.

Transformer does not operate →

Replace transformer

Transformer operates →

Check for plugged burner nozzle and properly spaced electrodes. If ok, replace electrodes.

No ↓

Disconnect power supply. Is fuel filter clean? Does fuel flow freely? Is fuel at bleeder on fuel pump?

No →

Clean or replace filter. Clean or look for pinched hoses.

Yes ↓

Test fuel solenoid circuit:
1. Disconnect power supply
2. Unplug black & yellow leads
3. Plug black female into yellow male
4. Connect power supply
5. Start machine using normal procedure
Does burner fire?

No →

Clean or replace fuel solenoid

Yes ↓

Test Thermostat circuit:
1. Disconnect power supply
2. Connect the yellow leads together
3. Plug orange male into black female
4. Connect power supply
5. Start machine using normal procedure
Does burner fire?

No →

Test flow switch circuit:
1. Disconnect power supply
2. Connect the black leads together
3. Plug the yellow male into the orange female
4. Connect power supply
5. Start machine using normal procedure
Does burner fire?

Yes ↓

Replace thermostat

Yes ↓

Clean or replace flow switch

Reference

Pump may look different but the locations of these items are similar.

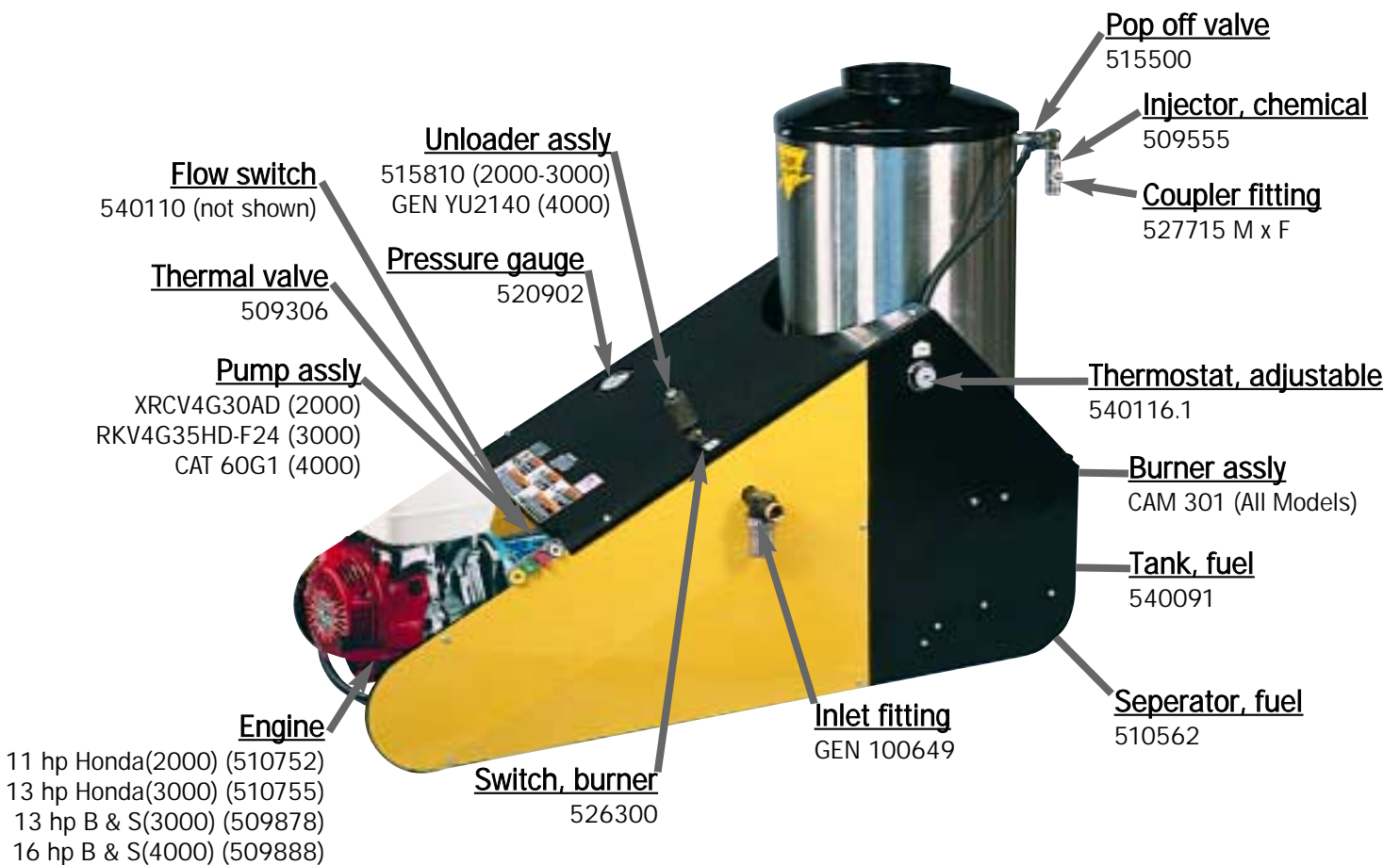
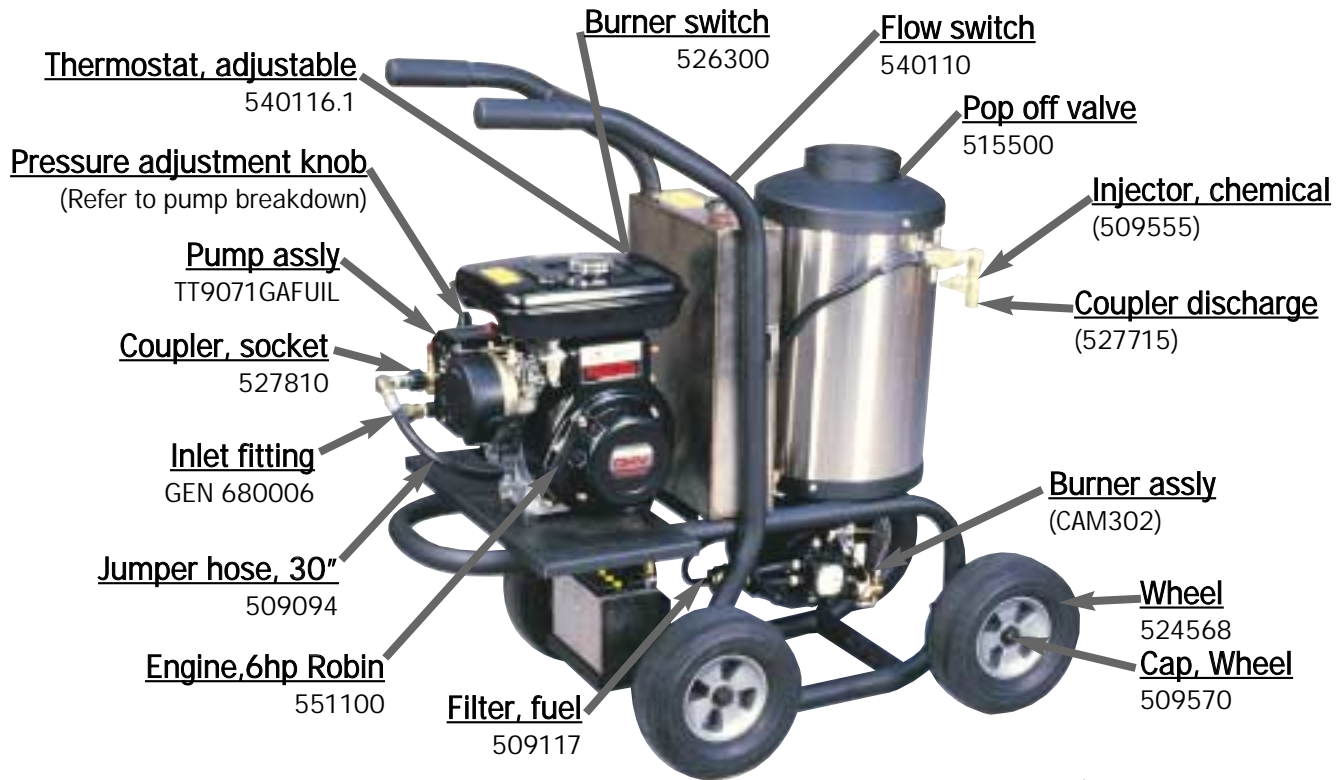



DC burner breakdown

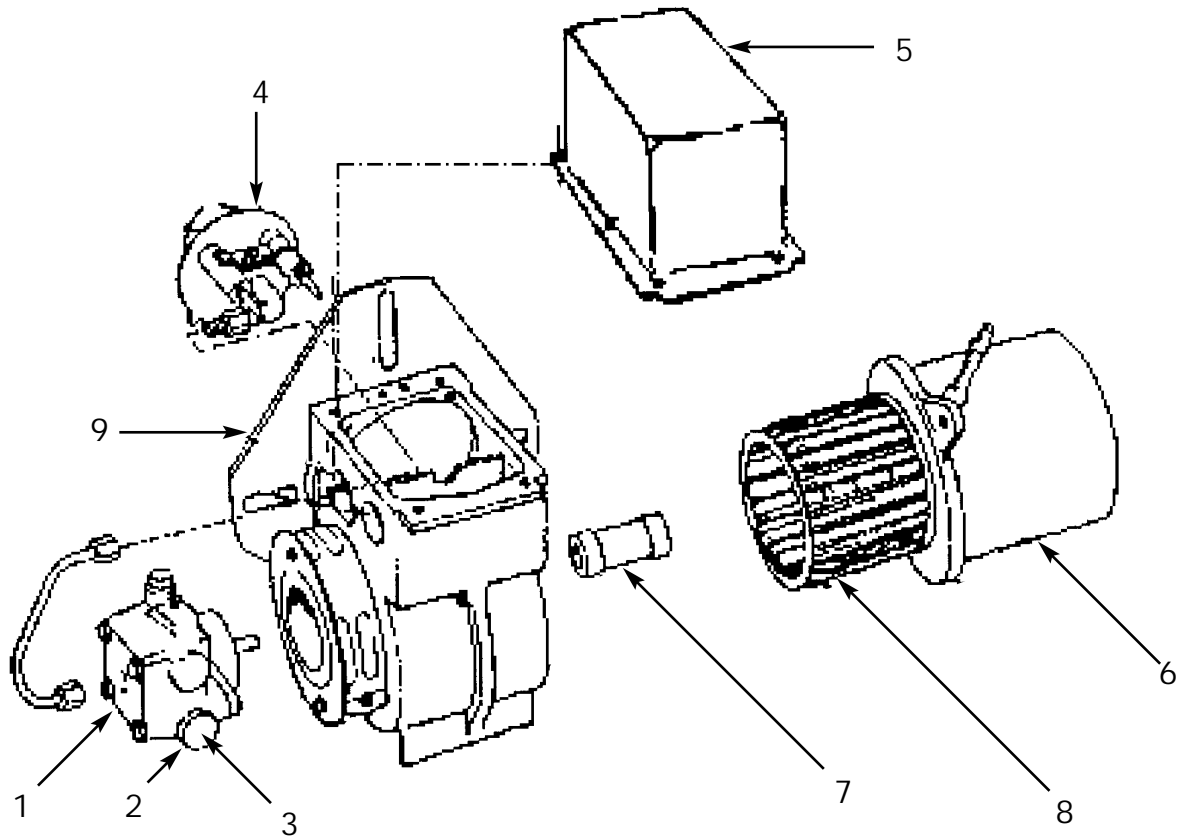

No.	Part No.	Description
1	B2184402U	Fuel pump w/ valve
2	B21754U	Valve coil
3	B21877U	Valve stem
4	B5780	Electrode set
5	B517760	Transformer (w/control board & cad cell)
6	B21699UF	Motor
7	B21405U	Coupler
8	B21404U	Blower wheel
9	B3616	Gasket
N/S	B51843U	Strainer kit
N/S	1010899	Vacuum switch
N/S	525105	Relay

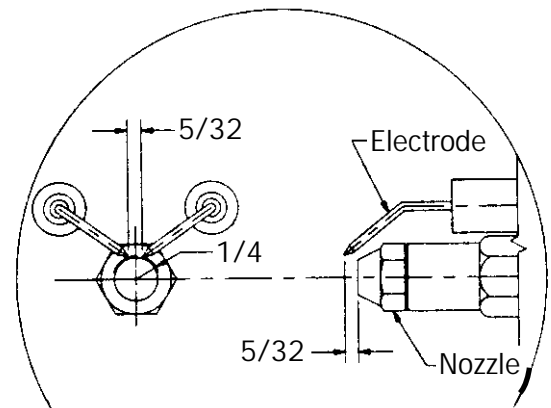

Electrode adjustments

Burner motor

Specifications 14 VDC, 1/6 horsepower, 13.5 Amps (max), 3450 RPM, CCW from shaft end, N.E.M.A. "M" flange

Replaceable brushes

Note: If polarity is reversed, motor will run backwards.

Lubrication The motor is permanently lubricated and has no need for oiling.

Brushes Check every 300 hundred hours of operation. If either of the brushes is shorter than 1/4" replace them. At no time allow the brushes to become shorter than 3/16"

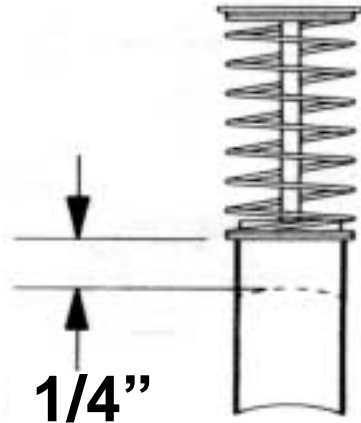

Gun/Wand breakdown



<u>Part no.</u>	<u>Description</u>
AR AL200	Gun section of wand
542002	Dual wand 1/2
510100	O-ring for Quick coupler and Twist-fast sockets
510065	Quick coupler socket 1/4"
527800	Twist fast socket 1/4" x 22mm

Replacement tips for all units

Flow	3 GPM	4 GPM
Tip description	1700SHDR	3000 / 4000 Q and TR-style
Red	00045 Q meg	0004 Q meg
Yellow	15045 Q meg	1504 Q meg
Green	25045 Q meg	2504 Q meg
White	40045 Q meg	4004 Q meg
Soap	4030 1/4 meg	4030 1/4 meg



Replacement Hoses

<u>Part no.</u>	<u>Description</u>
509073	20' x 3/8"
509074	30' x 3/8"
509080	40' x 3/8"
509085	50' x 3/8"
509081	100' x 3/8"



Hose Extensions (with coupler ends)

<u>Part no.</u>	<u>Description</u>
527650	20' x 3/8"
527651	40' x 3/8"
527653	50' x 3/8"
527660	100' x 3/8"