

OPERATORS MANUAL

for
MX, MXD and Wall Mount Style Models

MX and MXD Models



Features General pump

Models are:
1000MX, 1500AMX, 1500MX
and 20005MX



Features Cat pump

Models are:
1000MXDS, 1500AMXDS,
1500MXDS and 20005MXDS

Wall Mount Style Models



Models offered are:

1000WM and 1500WM with painted frame

1000WM/SS and 1500WM/SS with stainless
steel frame.

Thank You...

.....for selecting our products. Our personnel have proudly made every effort to ensure that your new Pressure Washer is of the quality that you expect. But things do occasionally go wrong. This is why every pressure washer is covered by a limited warranty. Among other things this warranty provides for the replacement of parts found to be defective during the operation of your new pressure washer. Please note that the owner/operator has certain obligations under the terms of the warranty. Be sure to read this manual for directions on proper installation, start-up, use and storage of your pressure washer.

Your new Pressure Washer was tested after production for proper pressure and flow. This process will leave a water residue in the pump sometimes. The dealer that you have purchased your new machine from should review with you the proper installation, start-up, use and storage. Most "Big" problems occur when shortcuts are taken in one of these processes. If a problem occurs you need some assistance with please feel free to contact us at the listing below:

**Warranty Service Center
520 Brooks Road
Iowa Falls, IA 50126
1-800-648-6007**

Be familiar with the model plate located on your machine. Have the model and code number with you when you call for service.

Statement of Warranty

The manufacturer of this pressure washer agrees to repair or replace designated parts that prove defective within 1 year from date of original purchase. Specific limitations and exclusions apply. To make claim under the terms of the warranty, all parts said to be defective must be returned to the Warranty Service Center listed above for warranty inspection. The judgements and decisions of the factory personnel concerning the validity of warranty claims are final. Items not covered by the warranty given us include:

Motors, Engines and Pumps: These components are covered by warranties given by their respective manufacturers. These warranties pass through to the end user. As a factory authorized and trained warranty service center the factory will honor the terms of all component warranties and satisfy claims of the appropriate warranty provisions.

Normal wear items are not covered by this warranty, hoses, nozzles, filters, valves and seals are considered normal wear items and are not covered by this warranty.

This warranty does not cover the following: machines used for rental purposes, damage resulting from shipping, accident, abuse, or acts of God, misuse or neglect. Neither is damage from repairs or alteration performed by non-factory authorized personnel or failure to install and operate equipment according to the guidelines put forth in the instruction manual.

The manufacturer will not be liable to any persons for consequential damage, for personal injury or for commercial loss.



WARNING

The following warnings must be followed, Failure to follow these warnings could result in serious personal injury or death!

Never allow children or untrained personnel to operate machinery.



Electrical equipment can cause shock and sparks.
Do not bypass or remove the grounding prong in any electrical plug.
Keep electrical plugs, connections and cords out of water and moisture.
Refer to instructions prior to equipment operation.
Disconnect from power source before servicing.
Inspect and repair damaged or exposed electrical components prior to use.
Never splice electrical cords on pressure washers.



High Temperature Water.
Wear protective clothing and face shield.
Do not direct water stream toward self or others.
Do not spray electrical apparatus.

High pressure water can cause death or serious injury.

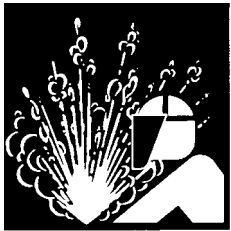

High pressure fluid can create a high pressure stream or ruptured vessel.
Wear safety face shield.
Relieve pressure before servicing.
Do not modify/repair/rework vessel or change safety relief or pressure setting.
Do not direct stream toward self or others.
Pressurized fluid streams and ruptured pressure vessels can cause death or serious injury.

Important Safety Instructions

WARNING - when using this product basic precautions should always be followed, including the following:

1. Read all the instructions before using the product.
2. To reduce the risk of injury, close supervision is necessary when a product is used near children.
3. Know how to stop the product and bleed pressure quickly. Be thoroughly familiar with the controls.
4. Stay alert - watch what you are doing.
5. Do not operate the product when fatigued or under the influence of alcohol or drugs.
6. Keep operating area clear of all persons.
7. Do not overreach or stand on unstable support. Keep good footing and balance at all times.
8. Follow the maintenance instructions specified in the manual.
9. "WARNING - Risk of Injection or Injury - Do Not Direct Discharge Stream At Persons."

SAVE THESE INSTRUCTIONS GROUNDING INSTRUCTIONS

This product must be grounded. If it should malfunction or breakdown, grounding provides a path of least resistance for electric current to reduce the risk of electric shock. This product is equipped with a cord having an equipment-grounding conductor and a grounding plug. The plug must be plugged into appropriate outlet that is properly installed and grounded in accordance with all local codes and ordinances.

DANGER - Improper connection of the equipment-grounding conductor can result in a risk of electrocution. Check with a qualified electrician or service personnel if you are in doubts to whether the outlet is properly grounded. Do not modify the plug provided with the product - if it will not fit the outlet, have a proper outlet installed by a qualified electrician. Do not use any type of adaptor with this product.

Initial setup and operation of your new pressure washer

- Inspection for freight damage.** When you receive your pressure washer be sure you check for concealed freight damage. Any damage should be noted with the delivering carrier. If you have any questions related to freight call the 800 number listed in the front of the manual.
- Inspection of oil levels** Check oil levels in the pump. Failure to check levels will result in equipment damage. Most pump are shipped with oil from factory and the crankcase are sealed, you may have to remove a shipping plug and install a dipstick in the pump.
- Water Supply** Your water supply must provide water to the equipment that exceeds the Gallon Per Minute {GPM} rate of your machine. You can check your GPM by using a 5 Gallon bucket and a timer. If your machine is 5 GPM or less and the bucket fills in less than a minute you have adequate supply. Some systems are effected by things like washing machines, livestock watering systems and flushing of toilets. Be sure the supply is still adequate when these operations are taking place. The water temperature cannot exceed 145 Degrees Fahrenheit on the MX models and 180 degrees Fahrenheit on the MXD and Wall Mount models and the pressure should not exceed 60 PSI. **Failure to secure adequate water supply will result in pump damage. DO NOT RUN PUMP DRY.**
- Water Quality** Your water should not contain particles larger than 80 microns. Although there are small filters installed on pressure washers that filter the water, they could only filter poor quality water for a short period of time before they clog. This would result in damage to the machine. Therefore you should insure no sand or scale particles are present in the water supply.
- Supply hose** Hook a garden hose from the hydrant to the machine, when doing this be sure to check the inlet water filter or screen. This hose should be at least 5/8" diameter and a length at least 15 feet. This 15' length helps isolate the water supply from pulsations from the pump. ***Many states require a Vacuum Break or backflow preventor be installed at the hydrant, before the garden hose, to insure the water source cannot be contaminated. Be sure to check local and state regulations upon installation.***
- Purge Air** Turn on the water supply and open the trigger gun, this will purge all the air from the system. Look for water leaks and stop any leak found. Leaks can cause erratic pump behavior.
- Electrical Supply** A circuit dedicated only to the pressure washer is recommended. This circuit should be installed by a licensed electrician and checked to supply adequate voltage ***Under Load***. Sometimes the distance from the panel is to long, the wire size is to small or the voltage is initially to low, this will cause the GFCI or Thermal to trip. If the GFCI trips or the thermal overload on the motor trips consult factory. Plug your cord into the receptacle. **DO NOT USE EXTENSION CORD!**
- Pump** Prior to turning on the power switches or your engine check the oil level in the pump.
- Turn on Power** Turn on the power switch. Pull trigger gun and check for adequate pressure.

During Operation The pressure was set at the factory during the testing procedure, no adjustments to the machine should be required for operation. **During operation do not leave the machine running for more than 2 minutes without the trigger gun being pulled. Although your machine has a by-pass valve on it and may have a thermal relief system, this can cause extensive pump damage. If machine will not be discharging water for more than 2 minutes, shut the machine off.**

Nozzles Your machine is supplied with interchangeable spray tips. The black tip lowers your pressure and draws chemical. The other tips are for high pressure rinse at different spray angles. Red is 0 degree, yellow is 15 degree, green is 25 degree and white is 40 degree. The yellow tip is used for most standard applications. Be sure the quick coupler is fully engaged before pulling the trigger gun. Failure to do may result in the tip becoming a projectile and may be lost or damage to property or persons may occur.

Chemical injector use. Your pressure washer is supplied with a downstream chemical injector with dual chemical selector. The 1/4" clear vinyl tube is to be inserted into the desired chemical to apply. Be sure to use the black, low pressure nozzle to inject chemical. The chemical injector will only open up and allow chemical into the line when this tip is used. This tip enables the pressure to drop to approximately 250 PSI to draw chemical. The injector can be turned on and off or the rate of injection can also be set by turning the knob that the clear vinyl tube attaches to. See calibration below.
Be sure to flush injection system with clear water after use.

Calibration The chart below is an average ratio observed using water as the test fluid to draw through the injector and serves only as a guide, your actual ratio will vary.

Setting on valve	Injection Ratio
9	6:1
8	8:1
7	10:1
6	13:1
5	20:1
4	28:1
3	35:1
2	50:1

For better accuracy, calibrate using the following formula:

$(\text{GPM} \times 128) \div (\text{ounces drawn in 1 minute}) = x:1$.

IE: If a 2.0 GPM machine draws 8 ounces of chemical in 1 minute: $\frac{(2 \times 128)}{8} = 32:1$

Hoses and couplers Factory supplied hoses are sized in length and diameter for best operational performance and sized within the pressure capabilities. Additional hose added to the machine may change the performance of the machine. Consult factory if you have any questions. When replacing or disconnecting the quick couplers be sure the machine is shut off and relieve the pressure from all hoses.

Shut down procedure

- Storage**
1. Turn off the power switch on the pressure washer.
 2. Relieve pressure on line by pulling trigger gun.
 3. Shut off water supply and disconnect garden hose.
 4. Be sure to check for water leaks or oil leaks that should be repaired before the next operation.
 5. If you are going to store the machine for extended period of times in cold climates be sure to anti-freeze the equipment. A 50% anti-freeze solution may be drawn in through the inlet of the pump using a short remnant of garden hose. This fluid should be run through the pump when the fluid is discharged from the pump discharge your machine is winterized. **Do not allow machine to freeze.**
- Pump**
- The pump oil should be changed after the first 50 hours of operation, then every year for average service or more frequently for extensive use or hostile environments {dusty or high moisture}
- Filters**
- Water filters, hoses and fittings should be checked prior to every operation for cleanliness, leaks and repair needs. Repair or replace as needed.
-

Troubleshooting - Common Problems and Solutions

- Low Nozzle Pressure**
- Low nozzle pressure is a common complaint. In a majority of instances, low nozzle pressure is generally caused by one of the following:
1. Plugged nozzle tip.
 2. Inlet screen plugged.
 3. Insufficient flow in gallons per minute (not pressure) to the pump.
 4. Unloader valve stuck open due to debris lodged under the check valve ball.
 5. Customer use of shut-off-type quick connectors.
 6. Plugged hose.
 7. Incorrect nozzle or soap tip installed.
- Surging Operation**
- Another complaint is that pressure *surges*. That is, when the trigger is pulled, pressure is satisfactory for a moment then falls off. When the trigger is released, pressure builds up to normal levels. This is generally a sign that the water supply cannot provide the flow rate (gallons per minute) required by the pump. Following are some possible solutions:
1. Make sure the supply is not restricted; that there are no under-sized fittings and the inlet screen is unobstructed.
 2. Make sure the flow rate of the water supply is sufficient for the pump. First, find the capacity of your pump in gallons per minute (gpm) as shown in the *Water Supply section on Page 5*. Then determine the flow rate of your supply by measuring the gallons that can be delivered in one minute. If your supply does not deliver the gpm your pump requires, do *not* use the pump. It will suck air, causing cavitation that can quickly damage pump components.
 3. Check for leaks in the supply fittings. Any leak will cause the pump to draw air and perform poorly.
- Soap Injector Not Working Properly**
- When a soap injector is not working properly, the problem is generally fairly easy to isolate. Check the following:
1. Make sure the Black, soap tip is installed. Soap injectors will *not* work when high pressure nozzles are installed.
 2. Be sure that the soap injector valve is turned on, and turn selector valve to desired setting.
 3. A piece of debris may be caught in the injector valve, injector ball valve, or orifice. Disassemble and clean the injector.
- Notice**
- User maintenance procedures include replacing valves and seal. Unloader components are **not** user serviceable. Repairs involving unloaders and crankcase components should be referred to the factory or a factory authorized repair center.

MX and MXD Gun Wand Assembly



Wall Mount Gun Wand Assembly



Part Number	Description
542081	MX and MXD Gun Wand Half
542082.1	MX and MXD Wand Half
510065	1/4" Quick Coupler for All units
510100	O-Ring for 1/4" Quick Coupler and Twist Fast for All units
509372	Wall Mount Gun
509370	Wall Mount Lance

Replacement Quick Tips For All Units

Flow	2.0 GPM	2.0 GPM	3.0 GPM	3.0 GPM
Tip Description	Model 1000MX 1000MXDS	Model 1500AMX 1500AMXDS	Model 1500MX 1500MXDS	Model 20005MX 20005MXDS
Black-Soap Tip	509520	509520	509520	509520
Red-0 Degree	0004 Q Meg	0035 Q Meg	0005 Q Meg	0004 Q Meg
Yellow-15 Degree	1504 Q Meg	15035 Q Meg	1505 Q Meg	1504 Q Meg
Green-25 Degree	2504 Q Meg	25035 Q Meg	2505 Q Meg	2504 Q Meg
White-40 Degree	4004 Q Meg	40035 Q Meg	4005 Q Meg	4004 Q Meg

2SFX PUMP

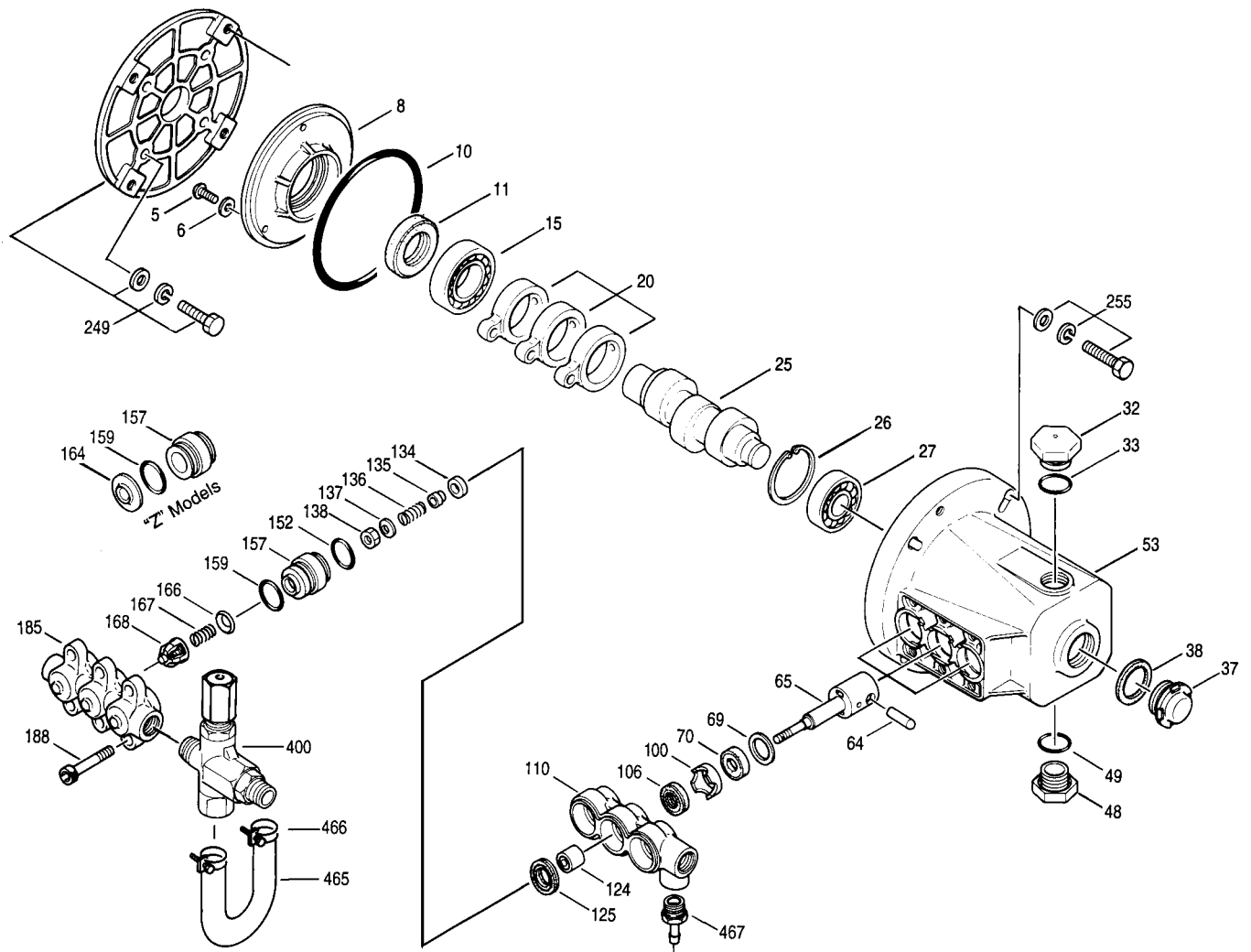

7500X UNLOADER

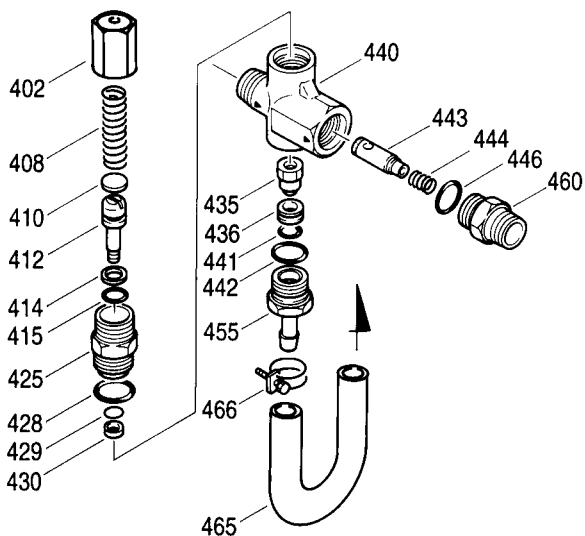

ITEM	PART NUMBER	DESCRIPTION	QTY
402	CAT 540081	CAP, HEX ADJUSTING	1
404	CAT 31047	NUT, LOCKING(OPTIONAL)	1
408	CAT 32094	SPRING, COIL (2000 PSI)	1
410	CAT 107672	RETAINER, SPRING	1
412	CAT 45694	STEM, PISTON (M5)	1
414	CAT 20184	BACK UP RING	1
415	CAT 14190	O-RING, RETAINER	1
425	CAT 107673	RETAINER, PISTON	1
428	CAT 13969	O-RING-70	1
429	CAT 14759	O-RING, BODY	1
430	CAT 107675	BACK UP RING, BODY	1
435	CAT 45696	ASSEMBLY, VALVE & BAL (M5)	1
436	CAT 107680	SEAT	1
440	-----	BODY	1
441	CAT 13963	O-RING, VALVE	1
442	CAT 13969	O-RING - 70	1
443	CAT 541060	VALVE, CHECK W/O-RING	1
444	CAT 45924	SPRING - 85G	1
446	CAT 13969	O-RING - 70	1
455	CAT 45865	BARB, BY-PASS FITTING	1
460	CAT 107681	FITTING, DISCHARGE (3/8" NPT)	1
465	CAT 46140	BY-PASS HOSE (5.5" x 1/4")	1
	CAT 45983	BY-PASS HOSE (9" x 1/4") (OPTIONAL)	1
466	CAT 45929	CLAMP, HOSE	2
468	CAT 32097	KIT, O-RING	1
		(Includes: 414, 415, 428, 429, 430, 441, 442, 446)	
485	Cat 7140	VALVE, THERMO(OPTIONAL)	1
	CAT 7135	VALVE, THERMO (OPTIONAL)	1
486	CAT 34600	TEE, T.V. MOUNT (OPTIONAL)	1
487	CAT 34576	NIPPLE, T.V. MOUNT (OPTIONAL)	1

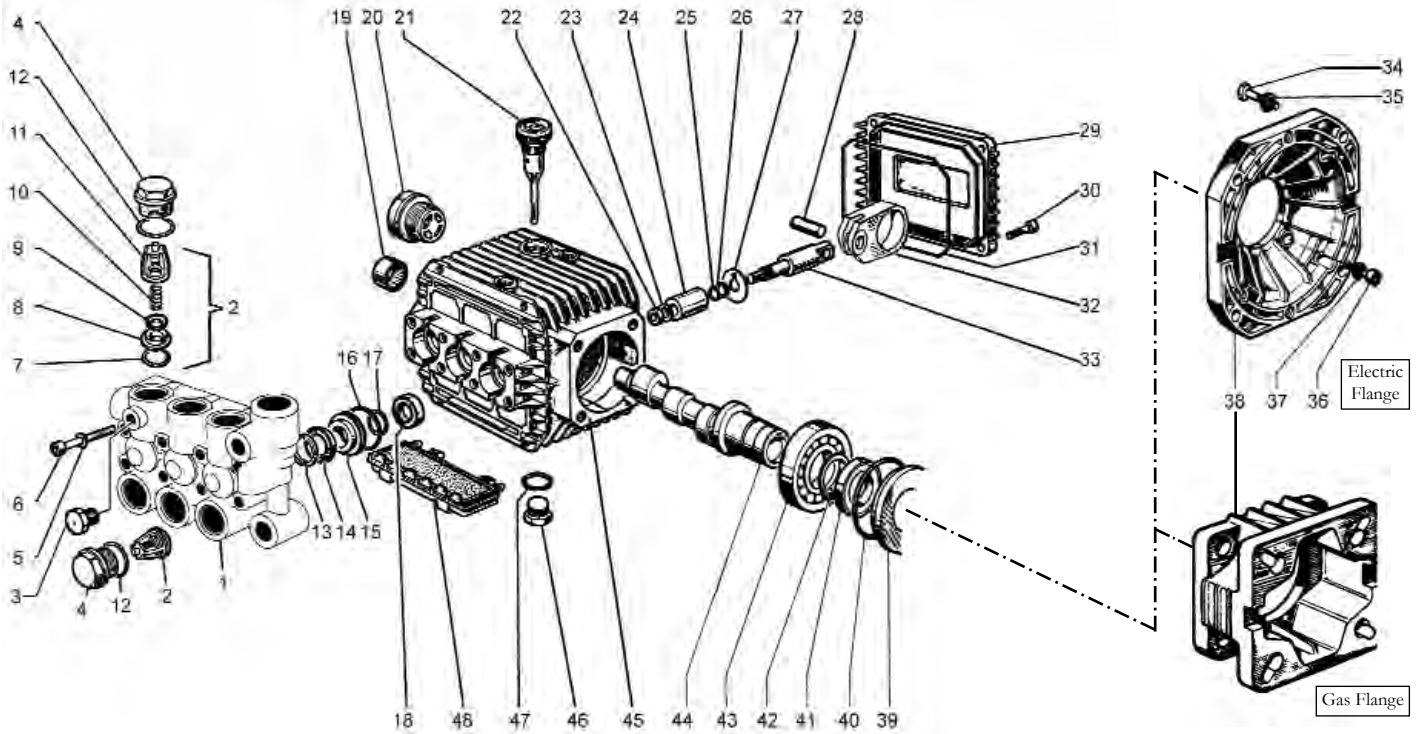

PARTS LIST

Pos.	Code	Description	Kit No.	Qty	Pos.	Code	Description	Kit No.	Qty
1	55120122	Manifold, Alum Nickel		1	25	90357200	O-ring		3
2	N/A	Valve assy, comp	K01	6	26	90502200	Anti-Ext ring		3
3	98204100	Plug 1/4 x 9 G		1	27	96707000	Flinger washer		3
4	98221800	Valve plug		6	28	N/A	Wrist pin		3
5	96693800	Washer		8	29	51160022	Back cover		1
6	99194300	Head bolt		8	30	99186700	Screw		4
7	N/A	O-ring	K01	6	31	N/A	O-ring	K100859	1
8	N/A	Valve seat	K01	6	32	N/A	Connecting rod		3
9	N/A	Valve poppet	K01	6	33	N/A	Piston guide		3
10	N/A	Valve spring	K01	6	34	N/A	Screw		4
11	N/A	Valve cage	K01	6	35	N/A	Washer		4
12	90384700	O-ring		6	36	99186700	Screw		4
13	N/A	Head-ring 15mm	K97	3	37	96693800	Washer		4
14	N/A	HP Packing 15mm	K97	3	38	10034622	Flange, Gas		1
15	51080070	Retainer 15mm		3		10034422	Flange, Electric		1
16	N/A	O-ring	K97	3	39	N/A	Spacer		1
17	N/A	LP seal	K97	3	40	N/A	O-ring	K100859	1
18	N/A	Oil seal	K100859	3	41	N/A	Seal	K100859	1
19	N/A	Needle bearing		1	42	N/A	Clip		1
20	97596800	Sight glass		1	43	N/A	Bearing		1
21	98210300	Dipstick		1	44	N/A	Crankshaft		1
22	92221600	Nut		3	45	N/A	Crankcase		1
23	96700800	Copper washer		3	46	98210000	Plug		3
24	51040009	Plunger 15mm		3	47	90383300	O-ring	K100859	1
					48	51209051	Shield		1

REPAIR KITS

Kit No.	K01	K97	K100859
Item No.s Included In Kit	7,8,9, 10,11, (2)	13,14, 16,17	18,31,40, 41,47
Number Of Assemblies In Kit	6	3	-
Description	Valve kit	Seal kit	Oil seal kit

TORQUE SPECS*

Position	Ft.- lbs
3	9.6
4	60.0
6	8.8
20	13.2
22	11.0
30	7.3
34	14.7
36	7.3
46	29.4

*Decrease torque by 20% if threads are lubricated.