



OPERATOR'S MANUAL FOR
HSP-SERIES
HOT WATER
PRESSURE WASHERS
(UTILIZES EMF SYSTEM PATENT #5,954,494)



 CAUTION
RISK OF INJURY!

READ MANUAL BEFORE OPERATING!

This manual is an important part of the pressure washer and must remain with the unit when you sell or rent it!

TABLE OF CONTENTS

INTRODUCTION	3
IMPORTANT SAFETY WARNINGS	4-7
RISK OF EXPLOSION OR FIRE	4
RISK OF ASPHYXIATION	5
RISK OF INJECTION OR SEVERE CUTTING INJURY	5
RISK OF ELECTROCUTION OR ELECTRICAL SHOCK.....	5
RISK OF BURNS	6
RISK OF BURSTING	6
RISK FROM MOVING PARTS.....	6
RISK OF BODILY INJURY	7
FEATURES	8-11
INSTALLATION & PREPARATION	12-14
ATTIRE	12
SET-UP.....	12
ENGINE/BURNER FUEL TANK.....	12
ADJUSTABLE PRESSURE DUAL LANCE.....	13
DUAL LANCE CONNECTION	13
WATER SUPPLY.....	13
UNLOADER	14
HEAT DUMP VALVE	14
PRE-START INSPECTION PROCEDURES.....	14
OPERATING INSTRUCTIONS	16-17
PRIMING THE PUMP	16
START-UP/COLD WATER OPERATION	16
HOT WATER OPERATION.....	17
CLEANING WITH DETERGENTS UNDER LOW PRESSURE	17
SHUTDOWN.....	17
STORAGE & MAINTENANCE	18-19
SPECIFIC MAINTENANCE	18
WINTERIZING	19
TROUBLESHOOTING	20-21
MAINTENANCE CHART	22
ACCESSORIES	23
STATEMENT OF WARRANTY	24
NOTES	25

 **WARNING**
The engine exhaust from this product contains chemicals known to the State of California to cause cancer, birth defects or other reproductive harm.

 **WARNING**
This product contains one or more chemicals known to the State of California to cause cancer and birth defects or other reproductive harm.

INTRODUCTION

Congratulations on the purchase of your new Mi-T-M HSP-Series hot water pressure washer featuring the patented Electro Magnetic Firing (EMF) System! You can be assured your Mi-T-M hot water pressure washer was constructed and designed with quality and performance in mind. Each component has been rigorously tested to ensure the highest level of acceptance.

This operator's manual was compiled for your benefit. By reading and following the simple safety, installation, operation, maintenance and troubleshooting steps described in this manual, you will receive years of trouble free operation from your new Mi-T-M hot water pressure washer. The contents of this manual are based on the latest product information available at the time of publication. Mi-T-M reserves the right to make changes in price, color, materials, equipment, specifications or models at any time without notice.

! IMPORTANT !

These paragraphs are surrounded by a "SAFETY ALERT BOX". This box is used to designate and emphasize Safety Warnings that must be followed when operating this pressure washer. Accompanying the Safety Warnings are "signal words" which designate the degree or level of hazard seriousness. The "signal words" used in this manual are as follows:

DANGER: Indicates an imminently hazardous situation which, if not avoided, **WILL** result in death or serious injury.

WARNING: Indicates a potentially hazardous situation which, if not avoided, **COULD** result in death or serious injury.

CAUTION: Indicates a potentially hazardous situation which, if not avoided **MAY** result in minor or moderate injury.



The symbols set to the left of this paragraph are "Safety Alert Symbols". These symbols are used to call attention to items or procedures that could be dangerous to you or other persons using this equipment.



ALWAYS PROVIDE A COPY OF THIS MANUAL TO ANYONE USING THIS EQUIPMENT. READ ALL INSTRUCTIONS BEFORE OPERATING THIS PRESSURE WASHER AND ESPECIALLY POINT OUT THE "SAFETY WARNINGS" TO PREVENT THE POSSIBILITY OF PERSONAL INJURY TO THE OPERATOR.

Once the unit has been uncrated, immediately write in the serial number of your unit in the space provided below.

SERIAL NUMBER _____

Inspect for signs of obvious or concealed freight damage. If damage does exist, file a claim with the transportation company immediately. Be sure that all damaged parts are replaced and that the mechanical and electrical problems are corrected prior to operation of the unit. If you require service, contact Mi-T-M Customer Service.

CUSTOMER SERVICE
CALL OUR TOLL-FREE NUMBER
for the Sales or Service Center nearest you!
800-553-9053

Please have the following information available for all service calls:



1. Model Number
2. Serial Number
3. Date and Place of Purchase



SAFETY WARNINGS

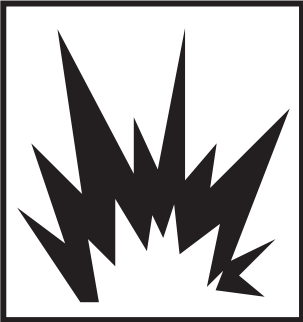

WARNING: When using this product, basic precautions should always be observed, including the following.
READ ALL SAFETY WARNINGS BEFORE USING PRESSURE WASHER



HAZARD	POTENTIAL CONSEQUENCE	PREVENTION
<p data-bbox="162 231 435 304">RISK OF EXPLOSION OR FIRE</p>  	<p data-bbox="511 231 925 357">Serious injury or death may occur from normal sparks in the multiple ignition sources or engine/burner exhaust.</p> <p data-bbox="511 588 925 661">Serious injury or death may occur as a result of improper fueling.</p> <p data-bbox="511 1291 925 1386">Serious injury or death may occur from a ground fire caused by a muffler spark.</p> <p data-bbox="511 1617 925 1711">Serious injury or death may occur if system safety's are not properly maintained.</p>	<p data-bbox="950 231 1485 357">Always operate pressure washer in a well ventilated area free of flammable vapors, combustible dust, gases or other combustible materials.</p> <p data-bbox="950 378 1485 504">Do not store the pressure washer near an open flame or any equipment such as a stove, furnace, water heater, etc., which utilizes a pilot light or sparking device.</p> <p data-bbox="950 525 1485 577">Do not use this pressure washer to spray flammable material!</p> <p data-bbox="950 598 1380 630">Do not smoke while filling fuel tanks.</p> <p data-bbox="950 640 1485 735">Never fill the fuel tanks while the engine is running or hot. Allow the engine to cool two minutes before refueling.</p> <p data-bbox="950 745 1485 808">Do not refuel indoors or in a poorly ventilated area.</p> <p data-bbox="950 829 1485 892">Always refuel slowly to avoid the possibility of spilled fuel which may cause a risk of fire.</p> <p data-bbox="950 903 1485 997">Engine Fuel Tank: If using a Gasoline Engine, refuel with gasoline only. Do not use diesel or fuel oil.</p> <p data-bbox="950 1008 1485 1102">Burner Fuel Tank (Black): When refueling the Burner Fuel Tank, use No. 1 or No. 2 fuel oil/diesel or kerosene. Do not use gasoline.</p> <p data-bbox="950 1123 1485 1270">Do not operate the unit if gasoline or diesel fuel is spilled. Wipe the pressure washer clean and move it away from the spill. Avoid creating any ignition until the gasoline or diesel fuel has evaporated.</p> <p data-bbox="950 1291 1485 1606">A spark arrester must be added to the muffler of this engine if it is to be used on any forest covered, brush covered or grass covered unimproved land. The arrester must be maintained in effective working order by the operator. In the state of California, the above is required by law. (Section 4442 of the California Public Resources Code.) Other states may have similar laws. Federal laws apply on Federal lands.</p> <p data-bbox="950 1627 1485 1774">This pressure washer has a Safety Relief device which should never be altered, modified, removed or made inoperative. If the device fails, replace immediately with only genuine manufacturer replacement part.</p>



SAFETY WARNINGS

READ ALL SAFETY WARNINGS BEFORE USING PRESSURE WASHER

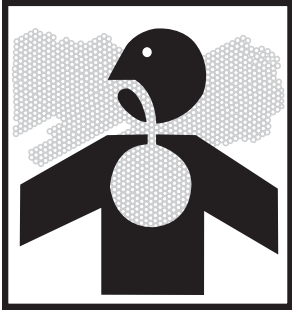
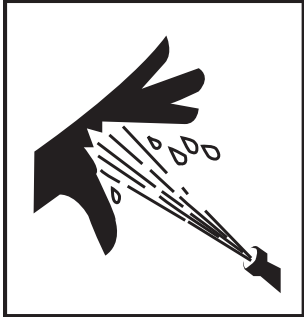



HAZARD	POTENTIAL CONSEQUENCE	PREVENTION
<p style="text-align: center;">RISK OF ASPHYXIATION</p> 	<p>Serious injury or death may occur from inhaling engine/burner exhaust or dangerous vapors. The engine exhaust from this product contains chemicals known to the State of California to cause cancer, birth defects, or other reproductive harm.</p>	<p>This pressure washer was designed for outdoor use only. Never operate this pressure washer in an enclosed area. Always make certain there is adequate ventilation (fresh outside air) for breathing and combustion. This will prevent the buildup of dangerous carbon monoxide gases. Beware of poorly ventilated areas, or areas with exhaust fans which can cause poor air exchange.</p> <p>Follow all safety instructions provided with the materials you are spraying. Use of a respirator may be required when working with some materials. Do not use this pressure washer to dispense hazardous detergents.</p>
<p style="text-align: center;">RISK OF INJECTION OR SEVERE CUTTING INJURY</p> 	<p>Serious injury or death could occur from high pressure spray penetrating the skin.</p>	<p>Keep clear of nozzle and spray! Never put your hand, fingers or body directly over the spray nozzle.</p> <p>Never point the high pressure discharge spray at yourself or anyone else.</p> <p>Always keep operating area clear of all persons.</p> <p>DO NOT allow children to operate this unit.</p> <p>SEEK EMERGENCY MEDICAL CARE if the spray appears to have penetrated the skin! DO NOT TREAT AS A SIMPLE CUT!!</p> <p>High pressure hoses and fuel lines should be inspected daily for signs of wear. If evidence of failure exists, promptly replace all suspect hoses and fuel lines to prevent the possibility of injury from the high pressure spray. If a hose or fitting is leaking, NEVER PLACE YOUR HAND DIRECTLY ON THE LEAK.</p> <p>NEVER operate the gun with the trigger wired in the open position. To prevent accidental discharge, the trigger gun should be securely locked when not in use.</p> <p>Before removing the spray nozzle or servicing the unit, ALWAYS shut off the unit and trigger the gun to release trapped pressure. (Even after you shut off the unit, there is high pressure water left in the pump, hose and gun until you release it by triggering the gun.)</p>
<p style="text-align: center;">RISK OF ELECTROCUTION OR ELECTRICAL SHOCK</p> 	<p>Serious injury or death may occur from contact with electricity.</p>	<p>DO NOT direct spray on or into electrical installations of any kind! This includes electrical outlets, light bulbs, fuse boxes, transformers, the unit itself, etc.</p> <p>DO NOT allow metal components of the pressure washer to come in contact with live electrical components.</p>



SAFETY WARNINGS

READ ALL SAFETY WARNINGS BEFORE USING PRESSURE WASHER

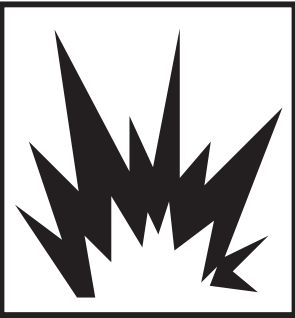

HAZARD	POTENTIAL CONSEQUENCE	PREVENTION
<p>RISK OF BURNS</p> 	<p>Serious injury may occur from touching the gasoline engine, muffler or heat exchanger. These areas can remain hot for some time after the pressure washer is shutdown.</p>	<p>Never allow any part of your body to contact the gasoline engine, muffler or heat exchanger.</p>
<p>RISK OF BURSTING</p> 	<p>Serious injury may occur from a pressure washer malfunction or exploding accessories if incorrect system components, attachments or accessories are used.</p> <p>Serious injury or death may occur if attempting to start the pressure washer when the pump is frozen.</p>	<p>Never make adjustments to the factory set pressures.</p> <p>Never exceed manufacturers maximum allowable pressure rating of attachments.</p> <p>Do not allow any hoses to make contact with the engine muffler, gasoline engine or heat exchanger to prevent the possibility of bursting. Avoid dragging the hoses over abrasive surfaces such as cement.</p> <p>Use only Mi-T-M recommended repair parts for your pressure washer.</p> <p>In freezing temperatures, the unit must always be warm enough to ensure there is no ice formation in the pump. Do not start the pressure washer if it has been transported in an open or underheated vehicle without first allowing the pump to thaw.</p>
<p>RISK FROM MOVING PARTS</p> 	<p>Serious injury may occur to the operator from moving parts on the pressure washer.</p>	<p>Before making any adjustments, be certain the engine is turned off and the ignition cable(s) is removed from the spark plug(s). Turning the machinery over by hand during adjustment or cleaning might start the engine and machinery with it.</p> <p>Do not operate the unit without all protective covers in place.</p>



SAFETY WARNINGS

READ ALL SAFETY WARNINGS BEFORE USING PRESSURE WASHER



HAZARD	POTENTIAL CONSEQUENCE	PREVENTION
<p>RISK OF BODILY INJURY</p> 	<p>Serious injury or death may occur from detergents contacting the skin.</p> <p>Serious injury can occur from loose debris being propelled at a high speed from the spray gun.</p> <p>Injury may occur if the operator loses his balance caused by the thrust of water traveling through the spray nozzle.</p> <p>Injury may occur from the pressure washer.</p>	<p>SEEK EMERGENCY MEDICAL CARE if you are using cleaning agents and the spray appears to have penetrated the skin! DO NOT TREAT AS A SIMPLE CUT! Be prepared to tell a physician exactly what kind of detergents you were using by reading the Material Safety Data Sheet (MSDS) provided with your detergent.</p> <p>Never use any solvents or highly corrosive detergents or acid type cleaners with this pressure washer.</p> <p>Protective equipment such as rubber suits, gloves and respirators are advisable, especially when using cleaning detergents.</p> <p>Keep all detergents out of the reach of children!</p> <p>ALWAYS wear protective goggles when operating the unit to shield the eyes from flying debris and detergents.</p> <p>DO NOT direct spray toward fragile materials such as glass for shattering could occur.</p> <p>Stay alert-watch what you are doing. Do not operate the unit when fatigued or under the influence of alcohol or drugs.</p> <p>NEVER squeeze the trigger unless securely braced.</p> <p>DO NOT overreach or stand on unstable support.</p> <p>Wet surfaces can be slippery, wear protective foot gear and keep good footing and balance at all times.</p> <p>NEVER trigger the gun while on a ladder or roof.</p> <p>ALWAYS hold on firmly to the gun/lance assembly when starting and operating the unit. Failure to do so can cause the lance to fall and whip dangerously.</p> <p>Know how to stop the pressure washer and bleed pressures quickly. Be thoroughly familiar with controls.</p> <p>DO NOT leave pressurized unit unattended. Shut off the pressure washer and release trapped pressure before leaving.</p> <p>DO NOT operate the unit if you see any fuel, oil or water leaks from the machine. DO NOT resume operation until the unit has been inspected and repaired by a qualified service person.</p> <p>NEVER run the engine with the governor disconnected or operate at excessive speeds.</p> <p>Place unit in a clean, dry, flat area for servicing. Before servicing the unit: turn the unit off, relieve the water pressure from the trigger gun, and allow the unit to cool down. Service in clean, dry, flat area. If applicable, block wheels to prevent unit from moving.</p> <p>Do not move the unit by pulling on the hose.</p>

!SAVE THESE INSTRUCTIONS!

HSP-SMALL FRAME FEATURES

HSP-2003-OMGH/OMGV MODELS

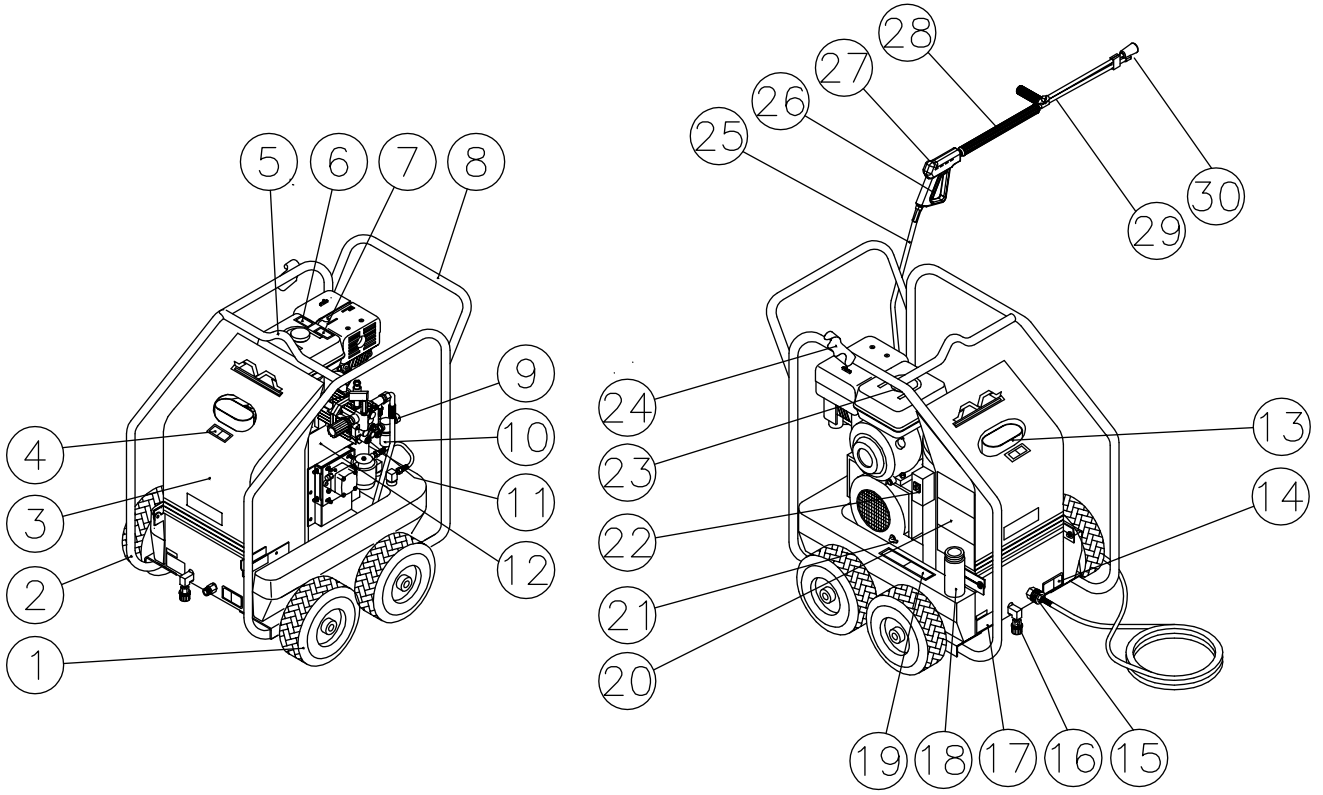

HSP-2003-1MGH/1MGV MODELS
HSP-2403-1MGH MODEL

HSP-2003-3MGH/3MGV MODELS
HSP-2403-3MGH MODEL

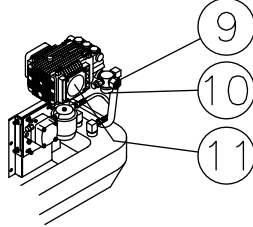
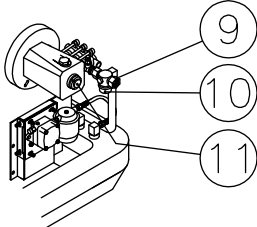

OMHSP004-032905-RZ

FEATURES LISTING

1. Pneumatic Wheels
2. Protective Rollcage
3. Protective Cover
4. Decal-Warning: Hot Surfaces
5. Center Balanced Lifting Eye
6. Decal-Caution: Cool before Refueling
7. Decal-Warning: Allow to Cool
8. Convenient Push/Pull Handle
9. Water Inlet
10. Water Strainer
11. High Pressure Pump
12. Beltguard
13. Heat Exchanger Exhaust
14. Decal-Warning: Do Not Modify Plumbing
15. High Pressure Outlet
16. Coil Drain Assembly
17. Decal-Data Plate
18. Burner Fuel Tank
19. Decal-Caution: Risk of Fire
20. Decal-Warning/Caution/Operating
21. Air Shutter Adjusting Arm
22. Burner On/Off Switch
23. Engine Gasoline Tank
24. Wand Holder
25. High Pressure Hose
26. Trigger Safety Lock
27. Trigger Gun
28. Insulated Lance
29. Adjustable Pressure Dual Lance
30. Nozzle

SPECIFIC UNIT INFORMATION

BODY/FRAME:	One piece, welded construction, full roll cage with solid steel axles, lifting hook and convenient push/pull handle, protective steel housing cover.
PORTABILITY:	Four pneumatic tires for easy mobility.
FINISH:	Powder Coated
HIGH PRESSURE HOSE:	3/8" x 50'
TRIGGER GUN ASSEMBLY:	Trigger controlled, safety lockoff, insulated lance.
DUAL LANCE:	Dual Lance, Insulated, w/adjustable pressure.

HSP-LARGE FRAME FEATURES

HSP-3004-1MGH/1MGV MODELS
HSP-3504-1MGH/1MGV MODELS

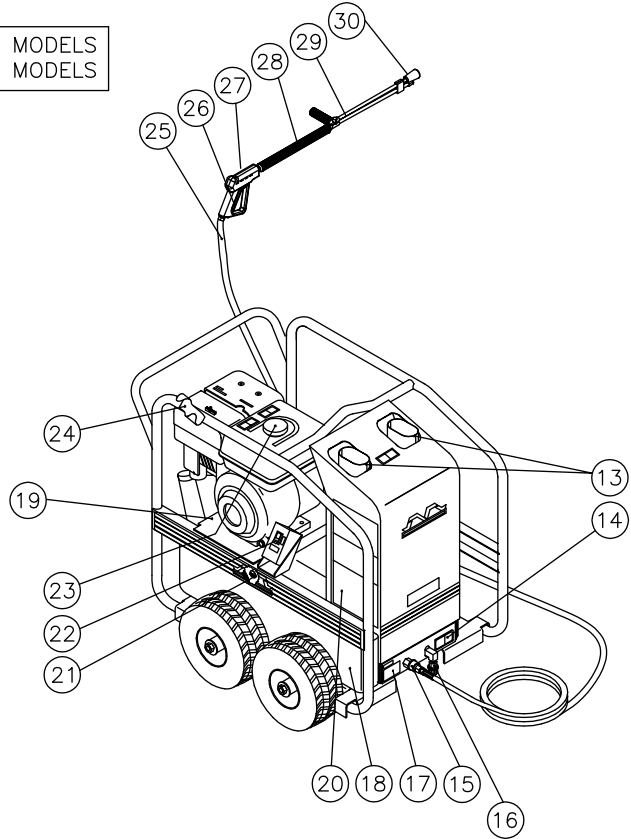
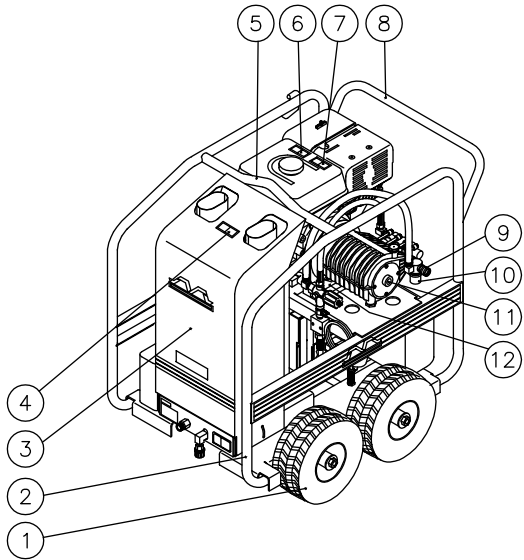

HSP-3004-3MGH/3MGV MODELS
HSP-3504-3MGH/3MGV MODELS

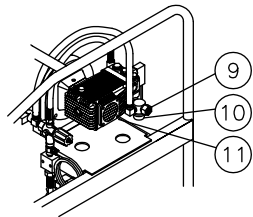

FEATURES LISTING

1. Pneumatic Wheels
2. Protective Rollcage
3. Protective Cover
4. Decal-Warning: Hot Surfaces
5. Center Balanced Lifting Eye
6. Decal-Caution: Cool before Refueling
7. Decal- Warning: Allow to Cool
8. Convenient Push/Pull Handle
9. Water Inlet
10. Water Strainer
11. High Pressure Pump
12. Beltguard
13. Heat Exchanger Exhaust
14. Decal-Warning: Do Not Modify Plumbing
15. High Pressure Outlet
16. Coil Drain Assembly
17. Decal-Data Plate
18. Burner Fuel Tank
19. Decal-Caution: Risk of Fire
20. Decal-Warning/Caution/Operating
21. Air Shutter Adjusting Arm
22. Burner On/Off Switch
23. Engine Gasoline Tank
24. Wand Holder
25. High Pressure Hose
26. Trigger Safety Lock
27. Trigger Gun
28. Insulated Lance
29. Adjustable Pressure Dual Lance
30. Nozzle

SPECIFIC UNIT INFORMATION

BODY/FRAME:	One piece, welded construction, full roll cage with solid steel axles, lifting hook and convenient push/pull handle, protective steel housing cover.
PORTABILITY:	Four pneumatic tires for easy mobility.
FINISH:	Powder Coated
HIGH PRESSURE HOSE:	3/8" x 50'
TRIGGER GUN ASSEMBLY:	Trigger controlled, safety lockoff, insulated lance.
DUAL LANCE:	Dual Lance, Insulated, w/adjustable pressure.



INSTALLATION & PREPARATION

ATTIRE:

Proper attire is essential to your safety. It is advised to utilize whatever means necessary to protect eyes, ears, and skin. Additional safety attire (such as respiratory mask) may be required when using detergent cleaning agents with this washer.



DANGER

RISK OF EXPLOSION OR FIRE!

DO NOT PLACE UNIT IN AN AREA WHERE FLAMMABLE GAS VAPORS MAY BE PRESENT. A SPARK COULD CAUSE AN EXPLOSION OR FIRE!

RISK OF UNIT BURSTING!

DO NOT STORE/OPERATE UNIT IN FREEZING ENVIRONMENTS!



WARNING

RISK OF ASPHYXIATION!

DO NOT OPERATE IN AN ENCLOSED AREA. USE THIS PRODUCT ONLY IN WELL VENTILATED AREAS!

THE EXHAUST CONTAINS CARBON MONOXIDE, A POISONOUS, ODORLESS AND INVISIBLE GAS. BREATHING THIS GAS CAN CAUSE SERIOUS INJURY, ILLNESS & POSSIBLE DEATH.

SET-UP:

1. This unit should only be placed on a level surface to ensure proper lubrication for the engine and water pump while operating. NEVER spray water directly on the unit.
2. Do not use unit in an area:
 - a. with insufficient ventilation.
 - b. where there is evidence of oil or gas leaks.
 - c. where flammable gas vapors may be present.This unit has multiple ignition sources that could cause an explosion or fire.
3. Be certain to block the wheels to prevent the unit from moving while operating.
4. Do not allow the unit to be exposed to rain, snow or freezing temperatures. If any part of the unit becomes frozen, excessive pressure may build up in the unit which could cause it to burst resulting in possible serious injury to the operator or bystanders.
5. Pump oil level should be checked before each use. Check the oil level indicator on the pump crankcase. Make certain the oil is in the center of the oil sight glass. If the level appears to be low, fill with Mi-T-M pump oil #AW-4085-0016.



DANGER

RISK OF FIRE!

- DO NOT SMOKE WHILE FUELING!
- DO NOT FILL THE FUEL TANK WHILE UNIT IS RUNNING OR HOT. ALLOW UNIT & ENGINE TO COOL FOR TWO MINUTES BEFORE REFUELING.
- DO NOT FILL FUEL TANK TO POINT OF OVERFLOWING. ALLOW APPROXIMATELY 1/4" OF TANK SPACE FOR FUEL EXPANSION.



WARNING

RISK OF EXPLOSION OR FIRE!

ALWAYS STORE FUEL AWAY FROM THE WASHER WHILE THE UNIT IS RUNNING OR HOT.

ENGINE/BURNER FUEL TANK:

1. Review "Risk of Explosion or Fire" Warnings pg. 4, before fueling.
2. Locate the Safety Decals on your unit and heed their warnings.
3. **Gasoline Engines:** When filling tank, gasoline fuel should be a minimum of 85 octane. DO NOT MIX OIL WITH GASOLINE. Gasoline fuel should be purchased in quantities that may be used within 30 days. Use of clean, fresh lead-free gasoline is recommended. Leaded gasoline may be used if lead-free is unavailable. DO NOT use gasoline containing methanol or alcohol.
Burner Fuel: When filling tank, use No. 1 or No 2 fuel oil/diesel or kerosene.
4. Check the engine oil level before starting the engine. (See Engine manual.)
5. Refer to the Engine Manual supplied with this unit for proper engine adjustment procedures.
6. **Review the engine manual accompanying this pressure washer for correct engine start-up and maintenance procedures.**

INSTALLATION & PREPARATION

DUAL LANCE ASSEMBLY WITH ADJUSTABLE PRESSURE:

This unit features a Dual Lance Assembly with adjustable pressure which allows the user to select a high or low pressure "fan" spray. Simply rotate the adjustable grip on the dual lance to achieve the desired pressure selection.

1. Selection of high pressure can be achieved by turning the adjustable grip on the Dual Lance assembly **counterclockwise** as shown in the figure below.
2. Selection of low pressure detergent application can be achieved by turning the adjustable grip on the Dual Lance **clockwise** as shown in the figure below. Once the pressure is low enough, the detergent injector on the pressure washer will draw detergent into the system. A water/detergent mixture exits from both the spray nozzle and detergent nozzle.

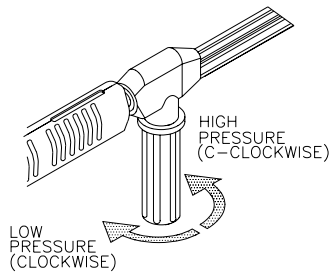

DUAL LANCE CONNECTION:

1. Be certain the trigger gun is locked in the "OFF" position.
2. Connect the dual lance assembly to the trigger gun assembly at this time. Be certain the connection is securely tightened.

WATER SUPPLY:

1. Select a water supply hose which is a quality grade of garden hose measuring at least 3/4" ID and no longer than 50 feet.
2. Check the water inlet strainer to ensure it is clean and free of any obstructions. As a strainer becomes obstructed, it restricts proper flow of water to the pump. This can result in cavitations which will prematurely cause failure of pump packings.
 - a. Unscrew the strainer cap from the unit.
 - b. Remove the strainer screen and clean, or replace.
3. Connect one end of the water supply hose to the water inlet of the unit. Connect the other end of the hose to your pressurized water supply.

NOTE: When connecting the water inlet to the water supply mains, local regulations of your water company must be observed. In some areas, the unit must not be connected directly to the public drinking water supply. This is to ensure there is no feedback of detergents into the water supply. (Direct connection is permitted if a backflow preventer is installed. Check with local authorities for approval.)

NOTE: If the mineral content of the water in your area is extremely high, the use of a water softener is recommended to prevent the possibility of excessive scale buildup inside the heat exchanger coil.

4. Follow the incoming water requirements listed below:
 - a. Water pressure must be a minimum of 20 pounds per square inch (PSI) and a maximum of 125 PSI. (A typical outdoor faucet will generally supply this PSI if turned completely "ON".)
 - b. Incoming GPM must be approximately one gallon more than the outgoing GPM stated on the pressure washer nameplate. (You can check GPM by timing how long it takes to fill a 5 gallon container.)
 - c. Incoming water temperature must not exceed 125°F. Excessive pump damage may result if the water temperature exceeds this acceptable level.
5. Never allow the unit to operate without the incoming water line attached and the water supply is completely turned on.

WARNING

RISK OF INJECTION CAUSING SEVERE INJURY!

- THE TRIGGER GUN SHOULD ALWAYS BE LOCKED IN THE OFF POSITION WHEN NOT IN USE!
- NEVER LOOK DIRECTLY AT THE NOZZLE UNLESS IT IS DISCONNECTED FROM THE TRIGGER GUN/DUAL LANCE ASSEMBLY!

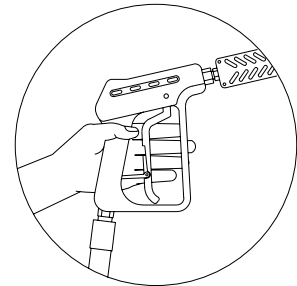

WATER INLET STRAINER

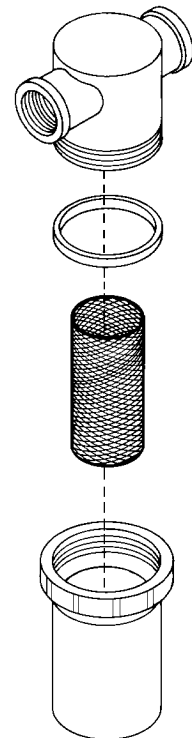

INSTALLATION & PREPARATION



CAUTION

RISK OF UNIT DAMAGE!

DO NOT OVERTIGHTEN THE UNLOADER. BREAKAGE COULD RESULT IN IMMEDIATE LOSS OF WATER PRESSURE AND COSTLY REPAIRS.

UNLOADER:

The HSP-0MGH/0MGV-MODELS: The unloader on these models is equipped with an adjustment knob so you can adjust the pressure. Should less pressure be required, simply turn the adjustment knob **counterclockwise**. To set back to maximum, turn the adjustment knob completely **clockwise**. **DO NOT OVERTIGHTEN.**

The HSP-1MGH/1MGV-MODELS: The unloader on these models is not equipped with an adjustment knob. **DO NOT** adjust pressure on your own. The pressure has been preset at the factory and should only be adjusted by a trained Service Representative.

THERMAL RELIEVE VALVE:

To ensure the water temperature does not exceed acceptable levels, never allow the pressure washer to operate in the bypass mode (with the unit running and the trigger closed) for more than three minutes.

A thermal relieve valve has been added to this unit to protect the pump. It may begin to open and release water if the water temperature in the pump has exceeded 140° F. This will allow fresh, cool water to enter the system, therefore preventing premature failure of pump packings.

PRE-START INSPECTION PROCEDURES:

Before starting the unit, perform the following procedures:

1. Check the oil level in the pump and engine.
2. Inspect the water inlet strainer. Clean or replace if necessary. See "Water Supply", #2, pg 13.
3. Check all hose connections to ensure they are securely tightened. See "Water Supply", #3, pg. 13.
4. Inspect for system water leaks, oil leaks and fuel leaks. If a fuel leak is found, **DO NOT START UNIT!** See "Risk of Explosion or Fire", pg. 4. Be sure that all damaged parts are replaced and that the mechanical problems are corrected prior to operation of the unit. If you require service, contact Customer Service.
5. Inspect high pressure hoses for kinking, cuts and leaks. If a cut or leak is found, **DO NOT USE HOSE!** Replace hose before starting unit. See "Risk of Injection" pg. 5. Be sure that all damaged parts are replaced and that the mechanical problems are corrected prior to operation of the unit. If you require service, contact Customer Service.

END OF PREPARATION INSTRUCTIONS

WARNING

THE FOLLOWING PAGES CONTAIN OPERATING AND MAINTENANCE INSTRUCTIONS.

DO NOT ATTEMPT TO OPERATE THIS PRESSURE WASHER UNTIL YOU HAVE READ AND UNDERSTOOD ALL SAFETY PRECAUTIONS AND INSTRUCTIONS LISTED IN THIS MANUAL.

INCORRECT OPERATION OF THIS UNIT CAN CAUSE SERIOUS INJURY!!

DO NOT ALTER OR MODIFY THIS EQUIPMENT IN ANY MANNER!

OPERATING INSTRUCTIONS



CAUTION

RISK OF UNIT DAMAGE.

BE CERTAIN THE HOSE, GUN & DUAL LANCE ASSY. ARE NOT CONNECTED TO THE UNIT WHILE PRIMING THE PUMP. PRIMING ALLOWS MINERAL DEPOSITS TO BE RELEASED FROM THE SYSTEM WHICH WOULD OBSTRUCT OR DAMAGE THE GUN AND NOZZLE ASSEMBLY RESULTING IN COSTLY REPAIRS.

PRIMING THE PUMP:

It is essential to prime the pump and flush the unit each time the water supply has been disconnected from the unit OR whenever the unit has set for any period of time. This unit has a steel coil which, after setting, will cause the water remaining in the coil from the previous usage to turn brown or black. This contaminated water must be flushed from the system before start-up. This procedure should be performed **without** the high pressure hose, gun and dual lance assembly installed.

DIRECT FEED: All units.

1. Turn on the water supply.
2. Low pressure water will begin flowing from the water outlet. This allows the unit to prime and purge any air from the system. The unit is primed when water flow is uninterrupted by air.
3. Once the unit is primed, turn off the water supply and connect the high pressure discharge hose to the water outlet of the unit. (Note: The trigger gun and dual lance assembly should already be connected to the high pressure discharge hose at this time.)
4. Turn on the water supply.

SUCTION FEED: HSP-1MGH/1MGV-MODELS only. These models have the ability to draw water from a static source and can provide a suction lift of 5' with a 3/4" inlet hose. We recommend the following for suction feed.

1. Immerse a 3/4" x 5' long inlet hose into the water supply.
2. Start the engine following the start up procedures given in the engine manual accompanying this unit.
3. Adjust the engine to a low speed until you see water exiting the water outlet.

NOTE: This may take up to 3-5 minutes. Adjust the engine throttle back to full RPM.

4. Once the unit is primed, stop the engine and connect the high pressure discharge hose to the water outlet of the unit.

NOTE: The trigger gun and dual lance assembly should already be connected to the high pressure discharge hose at this time.



DANGER

RISK OF INJECTION CAUSING SEVERE INJURY!

-KEEP CLEAR OF NOZZLE! NEVER PLACE HAND OR FINGERS IN FRONT OF NOZZLE!
-DO NOT DIRECT DISCHARGE STREAM AT PEOPLE OR PETS!

START-UP/COLD WATER OPERATION:

1. Refer to the "Safety Precautions" pgs. 4-7 before starting the unit.
2. Locate the Safety Decals on your unit and heed their warnings.
3. Ensure the burner switch is in the "OFF" position.
4. Pointing the trigger gun in a safe direction, unlock the trigger gun and squeeze the trigger. Hold the trigger gun open while starting the engine according to the manufacturer's instructions in the engine manual accompanying this unit.
5. Once the engine has started, ensure the engine throttle is adjusted to full RPM and perform the following procedures with the trigger gun open:
 - a. Inspect for system water leaks, oil leaks and fuel leaks. If a fuel leak is found, TURN UNIT OFF IMMEDIATELY! See "Risk of Fire", pg. 4. Be sure that all damaged parts are replaced and that the mechanical problems are corrected prior to operation of the unit. If you require service, contact Customer Service.
 - b. Inspect high pressure hoses for kinking, cuts and leaks. If a cut or leak is found, DO NOT TOUCH HOSE AT LEAK!!! TURN UNIT OFF IMMEDIATELY! Replace hose before starting the unit. See "Risk of Injection", pg. 5. Be sure that all damaged parts are replaced and that the mechanical problems are corrected prior to operation of the unit. If you require service, contact Customer Service.
6. At this point, the unit is operating as a cold water pressure washer. Trigger the gun several times and try adjusting the water pressure. NEVER place hand or fingers in front of the nozzle or look directly into the nozzle! High pressure water creates a risk of severe injury!
7. Do not allow unit to operate in bypass mode (with trigger closed) for more than three minutes without triggering the gun. Failure to follow this simple rule can cause premature failure of pump packings, resulting in costly pump repair.
8. Your pressure washer can deliver high pressure spray and a variety of spray patterns using cold water. If you wish to use the Hot Water application or Cleaning with Detergents, see page 17 for the correct procedures.



CAUTION

RISK OF DAMAGE.

DO NOT ALLOW SPRAY PATTERN TO REMAIN ON A FIXED AREA FOR AN EXTENDED PERIOD OF TIME. POSSIBLE DAMAGE MAY OCCUR TO THE AREA.

OPERATING INSTRUCTIONS

HOT WATER OPERATION:

1. Follow the steps outlined for "START-UP/COLD WATER OPERATION".
2. Move the Burner Switch to the ON position. On initial start-up, water will begin turning hot in approximately 20 seconds and will reach maximum temperature in approximately 2-1/2 minutes, provided the trigger remains squeezed. The burner will stop firing when the trigger is released.

NOTE: While spraying, it is normal for the burner to fire intermittently. The high-limit switch will cause combustion to cease when the temperature of the discharged water exceeds the maximum temperature setting of the switch. Combustion will begin again when the temperature drops below the minimum setting.

At this point, the unit is operating as a hot water pressure washer. Be certain to be extremely cautious when adjusting the pressure and controlling the trigger gun/dual lance assembly to avoid the possibility of burns.

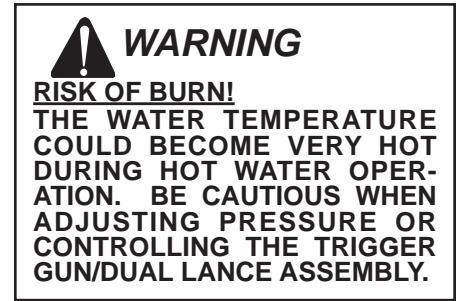

CLEANING WITH DETERGENTS UNDER LOW PRESSURE:

NOTE: This feature is designed for use with mild detergents only. Since the cleaning solution travels through the heat exchanger coil, DO NOT use corrosives as they will cause extensive damage as well as pose a considerable safety hazard.

1. Refer to "Risk of Bodily Injury/Detergents" pg. 7. Be certain to wear protective safety attire as stated on pg. 12.
2. Prepare detergent solution according to label directions. (Never pump acids, alkalines, abrasive fluids or solvents through the unit. Due to the unknown and often corrosive characteristics of many detergents commonly used in the pressure washer cleaning industry, it is recommended to use only Mi-T-M detergents with this unit.)
3. Fully immerse the *strainer end* of the clear vinyl detergent hose into the detergent solution.
4. Adjust the amount of detergent desired by locating the adjustment knob at the end of the clear vinyl hose. Turn the knob completely counterclockwise to set at maximum siphon rate. Be certain the adjustable grip on the dual lance is turned completely **clockwise** for low pressure detergent operation.

NOTE: This injection system is designed to apply detergents under low pressure only. It will not allow detergent solutions to be introduced into the system unless the dual lance is set in the low pressure mode.

5. To apply solution; unlock the trigger gun and squeeze the trigger. In a few moments a detergent/water mixture will exit the nozzle. Start spraying the lower portion of the surface being cleaned and move up, using long overlapping strokes. Applying from the bottom up helps avoid streaking. Allow to soak briefly. Avoid working on hot surfaces or in direct sunlight to minimize the chances of the detergent drying, which may result in damaging surfaces. Be certain to clean a small section at a time.
6. To rinse; lock the trigger gun in the "OFF" position, rotate the adjustable grip on the dual lance **counterclockwise** for high pressure. Unlock the trigger gun and spray. It will take about 30 seconds to purge all detergent from the line. For best rinsing results, start at the top and work down.
7. Siphon a gallon of water through the low pressure detergent injection system after each use. This prevents the possibility of corrosion or detergent residue causing mechanical problems during the next use.

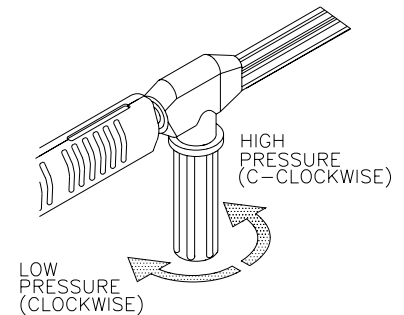

SHUT-DOWN:

1. Move the burner switch to the OFF position.
2. Squeeze the trigger and discharge the water for a period of three minutes to cool the heat exchanger and high pressure hose. (Insufficient cool down period of the high pressure hose will cause excessive wear and eventual rupturing of the hose.)
3. **DO NOT close the choke to stop the engine.** Backfire or engine damage may occur.
4. Move the engine On/Off Switch to the "off" position.
5. Close the engine fuel shut-off valve.
6. Turn off the water supply and trigger the gun momentarily to relieve trapped pressure.
7. Disconnect and store hoses. Store unit in a non-freezing environment.

STORAGE & MAINTENANCE

SPECIFIC MAINTENANCE:

ENGINE: The engine instruction manual accompanying your unit, lists specific procedures for maintenance of the engine. Following the engine manufacturer's recommendations will extend engine life.

PUMP: Change the pump oil after the first 50 hours of operation. After initial change, every 3 months or 250 hour intervals are recommended. If oil appears dirty or milky, changes may be required in greater frequency. Use Mi-T-M pump oil #AW-4085-0016 and fill only to the center of the oil sight glass. DO NOT overfill.

COUPLERS: There are o-ring seals inside the couplers which will deteriorate. To replace, simply install a replacement o-ring to correct the leak. (Additional o-rings can be purchased from your dealer.)

NOZZLE: Water flow through the spray nozzle will erode the orifice, making it larger, resulting in a pressure loss. Nozzles should be replaced whenever pressure is less than 85% of the maximum. The frequency of replacement will depend upon such variables as mineral content in the water and number of hours the nozzle is used.

FUEL WATER SEPARATOR: The fuel filter has a built in water separator. Occasionally the water has to be drained from the separator. Follow the procedures listed below:

1. Check the collection bowl daily.
2. Ensure the unit is off and place an oil catch basin under the fuel cartridge.
3. Loosen the drain plug to allow the fuel/water contaminants to flow into the catch basin.
4. Retighten the drain plug when completed.
5. Dispose of drainage according to environmental regulations in your area.

BURNER AIR ADJUSTMENT: The air shutter has been factory preset for proper operation between sea level and 2000 feet elevation at standard conditions (60°F ambient water and air temperatures). To assure maximum combustion efficiency at colder temperatures and higher altitudes, it will be necessary to adjust the air supply to the combustion chamber. A smoke spot test is recommended during any air shutter adjustment. This will aid in maximizing the burner efficiency and avoid inefficient operation and excessive sooting of the combustion chamber.

1. The machine must be running and the burner ON.
2. Take a smoke spot test to determine if more or less air is required for proper combustion.
 - a. HSP-SMALL FRAME SERIES:
 1. If the test is greater than a #3 smoke, turn the shutter arm **clockwise** to increase the air flow into the combustion chamber.
 2. If the test is yellowish in color, turn the shutter arm **counterclockwise** to decrease the air flow into the combustion chamber.
 - b. HSP-LARGE FRAME SERIES:
 1. If the test is greater than a #3 smoke, turn the shutter arm **counterclockwise** to increase the air flow into the combustion chamber.
 2. If the test is yellowish in color, turn the shutter arm **clockwise** to decrease the air flow into the combustion chamber.
3. Hold onto the air shutter adjusting arm and loosen the locking nut. Move the shutter in 1/8" increments and retighten the locking nut after each 1/8" movement.
4. Trigger the gun on and off slowly to make sure there is proper ignition. Slight or no puffing on the ignition, and a smoke spot test of less than #3 smoke is good.
5. Repeat steps 2 and 3 until step 4 is attained.

LEAKS: Promptly eliminate any leaks found in the pumping system by removing suspect parts, applying thread sealant to the threads and reinstalling.

NOTE: If using teflon tape, be certain no tape gets inside any plumbing to prevent the possibility of a plugged spray nozzle.

STORAGE & MAINTENANCE

WINTERIZING:

For storage and transportation purposes in subfreezing ambient temperatures, it will be necessary to winterize this unit. This unit must be protected to the lowest incurred temperature for the following reasons:

1. If any part of the pumping system becomes frozen; excessive pressure may build up in the unit which could cause the unit to burst resulting in possible serious injury to the operator or bystanders.
2. The pumping system in this unit may be permanently damaged if frozen. FREEZE DAMAGE IS NOT COVERED BY WARRANTY.

If you must store your unit in an area where the temperature may fall below 32°F, you can protect your unit by following the procedure outlined below.

1. Gather the following items:
 - a. Two 5 gallon containers.
 - b. One gallon of antifreeze. (Use an environmentally safe antifreeze.)
 - c. Water supply.
 - d. Three foot hose, 1/2-3/4 I.D. with a 3/4 inch male garden hose fitting.
2. Procedure:
 - a. To start winterizing, unit must be primed and run according to the "Start-up/Cold Water Procedures" listed on page 16.
 - b. After priming and running, shut off the unit and water supply.
 - c. Relieve system pressure by pointing the trigger gun in a safe direction and squeezing the trigger until water flow ceases to exit the Dual Lance Assembly.
 - d. Lock the trigger gun in the OFF position and remove the Dual Lance assembly.
 - e. Remove the water supply hose from the unit and attach the 3 foot hose securely to the inlet connection.
 - f. Shut off the detergent injector.
 - g. Fill one 5 gallon container with water.
 - h. Holding the 3 foot hose in an upright position, completely fill the hose with water. Then plug the hose outlet with your thumb or finger. Place the plugged end into the 5 gallon container of water.
 - i. Start the unit. Trigger the gun several times until all the air is worked out of the system (unit is primed). It may be necessary to adjust the engine RPM down to an idle to aid in priming.

NOTE: Proper winterizing is based on the recommended manufacturer's instructions listed on the "Protection Chart" shown on the back label of most antifreeze containers.

- j. With the trigger gun held open, siphon enough water out of the 5 gallon container until there is just enough water left to mix with the antifreeze.
 - k. Point the trigger gun into the empty container.
 - l. Trigger the gun until the antifreeze begins to exit the trigger gun. Release the trigger for 3 seconds, then trigger the gun for 3 seconds. Continue cycling the trigger gun several times until all the antifreeze mixture is siphoned from the container.
 - m. Detach the 3 foot hose from the unit and drain any excess antifreeze back into the 5 gallon container.
 - n. Disconnect the hose and trigger gun from the unit and drain any excess antifreeze back into the 5 gallon container.
 - o. Store the hose, trigger gun and dual lance assembly with the unit in a safe area.
 - p. Store antifreeze solution for next use or dispose of according to state EPA laws.
3. Optional Procedure:
 - a. Shut the unit and water supply off.
 - b. Relieve system pressure by pointing the trigger gun in a safe direction and squeezing the trigger until water flow ceases to exit the nozzle.
 - c. Disconnect and drain the hose, trigger gun and dual lance assembly.
 - d. Remove the hose from the inlet side of the heat exchanger coil.
 - e. Start the unit and allow it to run until all the water exits the unit. Once the water has stopped flowing from the unit, turn off.

NOTE: When using this procedure, caution should be used as ice chips can form from drops of water which could cause the unit to burst if starting before completely thawed.

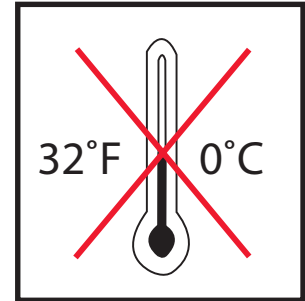
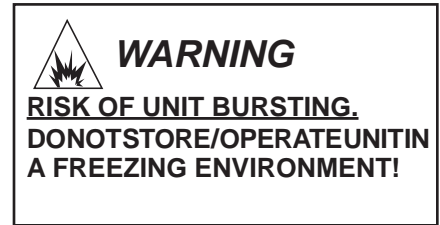

COIL DRAIN PLUG

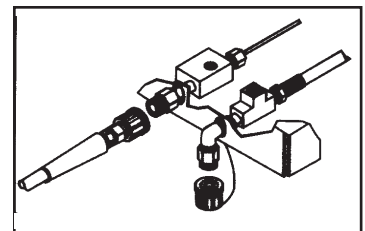

TROUBLESHOOTING

SYMPTOM	PROBABLE CAUSE	REMEDY
Engine will not start.	Various engine problems.	Refer to the Engine Manual accompanying your unit.
	Unit components are frozen.	Allow to thaw. If any part of the unit becomes frozen; excessive pressure may build up in the unit which could cause the unit to burst resulting in possible serious injury to the operator or bystanders.
No discharge at nozzle when trigger mechanism is squeezed.	Inadequate water supply.	Ensure hose is 3/4" diameter and incoming water supply is turned on.
Low or fluctuating pressure.	Kink in water inlet hose.	Remove kink.
	Kink in high pressure discharge hose.	Replace kinked high pressure hose.
	Water inlet screen obstructed.	Remove screen, clean or replace.
	Pump sucking air. (Prime eliminated)	Tighten all water intake connections Eliminate leaks in intake line.
	Adjustable Grip on Dual Lance is not in high pressure mode.	Turn grip counterclockwise to high pressure.
	Obstructed or worn spray nozzle.	Remove, clean or replace.
	Damaged or obstructed valve assy. on pump.	Remove, inspect, clean or replace.
	Pump packings worn.	Replace packings.
Water is leaking from Heat Dump Valve.	Unloader/Bypass valve not operating correctly.	Repair or replace.
	Water temperature is too high.	Do not allow unit to operate in bypass mode (with the trigger gun closed) for more than three minutes.
	Defective valve.	Replace.
Oil appears milky or foamy.	Water in oil.	Change pump oil. Fill to proper level.
Oil leaking from unit.	Worn seals or o-rings.	Contact Service.
Detergent will not siphon into Low Pressure Detergent mode.	Detergent strainer is not completely submerged in detergent solution.	Check, submerge if necessary.
	Detergent strainer obstructed.	Inspect, clean or replace.
	Detergent hose cut, obstructed or kinked.	Inspect, clean or replace.
	Detergent adjusting knob turned to closed position.	Open adjusting knob. Refer to "Cleaning with Detergents" pg. 17.
	Adjustable grip on dual lance is not in low pressure mode.	Turn grip clockwise to move to low pressure.
	Nozzle assembly is plugged.	Clean or replace.
	Too many high pressure hose extensions attached to the water outlet.	Use one extension maximum.
Water flows back into detergent container.	Ball & Spring in Venturi stuck.	Remove, clean or replace.
	Ball & Spring in Venturi reversed, missing or corroded.	Remove, clean or replace.
Water flows from the nozzle when the trigger gun is locked in the "OFF" position.	Trigger gun is malfunctioning.	Repair or replace.

TROUBLESHOOTING

SYMPTOM	PROBABLE CAUSE	REMEDY
Water is leaking under heat exchanger coil.	Coil drain plug is not installed.	Install.
	Safety relief device is relieving caused by an unloader or pressure switch problem.	<ol style="list-style-type: none"> 1. Detect and correct unloader or pressure switch problem. 2. Replace safety relief device. NEVER run unit without safety relief device. Doing so can cause an explosion!
Burner will not ignite	Burner switch is not turned on.	Check switch position.
	Out of fuel.	Refuel.
	Trigger gun is closed.	Open trigger gun for pressure.
	EMF Drive belt loose or broken.	Adjust or replace as necessary.
	Flexible coupler broken.	Replace.
	Dirty or clogged fuel filter/water sep.	Drain or replace as necessary.
	Fuel pump sucking air.	Tighten all fuel intake connections. Eliminate leaks in intake line.
	Fuel pump inoperative.	Check pressure, replace if needed.
	Fuel pickup screen is obstructed.	Consult Service.
	Dirty or clogged fuel nozzle.	Replace fuel nozzle.
	Ignition module.	Consult Service.
	Ignition electrodes damaged or worn.	With unit running and trigger gun closed, look through burner sight glass to ensure there is sparking across electrodes.
	No voltage.	Consult Service.
	Pressure switch override.	Pressure should be over 250 PSI/ 18 Bar to allow burner to come on.
	High limit switch override.	Allow unit to cool down before reigniting.
Improper burner air adjustment.	Adjust as shown on page 18.	
Fuel solenoid valve failure.	Replace.	
Burner runs erratically.	Water in the fuel oil.	Drain fuel filter/water separator, drain fuel tank and replace with clean fuel.
	Dirty fuel filter/water separator.	Replace element.
	Dirty fuel nozzle.	Replace.
	Improper air adjustment setting.	Adjust as shown on page 18.
	Fuel pickup screen is obstructed.	Consult Service.
Fuel pump malfunctioning.	Replace.	
Burner runs, but will not heat.	Poor or improper fuel supply.	Check fuel to ensure it is correct. Drain tank and filter if necessary and refill with proper fuel.
	Low fuel pump pressure.	Check fuel pump pressure, replace if needed.
	Dirty fuel nozzle.	Replace.
	Improper air adjustment setting.	Adjust as shown on page 18.
	Fuel pickup screen is obstructed.	Consult Service.
Scale build up in heat exchanger coil.	Consult Service.	
Burner discharges white smoke.	Low on fuel.	Refuel. If white smoke persists, consult Service.
	Excessive air supply.	Adjust as shown on page 18.
Burner discharges black smoke.	Insufficient air supply.	Adjust as shown on page 18.

MAINTENANCE CHART

PROCEDURE	DAILY	3 MONTHS	6 MONTHS	9 MONTHS	12 MONTHS
Check engine oil level	X				
Change engine oil****		X	X	X	X
Check water pump oil level	X				
Change water pump oil **		X	X	X	X
Oil leak inspection	X				
Fuel leak inspection	X				
Water leak inspection	X				
Hose inspection	X				
Water inlet filter inspection	X				
Check fuel filter/water separator	X				
Inspect belt		X	X	X	X
Replace high pressure nozzle***		X	X	X	X
Replace fuel filter/water separator					X
Inspect fuel pump filter*					X
Replace fuel nozzle*					X
Check burner air adjustment		X	X	X	X
Check burner electrodes*					X
Test water pressure*		X	X	X	X
Test fuel pressure*		X	X	X	X
Test water temperature*		X	X	X	X
Descale coil****					X

* Must be performed by an authorized service technician.

** The pump oil must be changed after the first 50 hours of operation and every 250 hours or 3 months, whichever comes first.

*** High pressure nozzle should be replaced whenever pressure is less than 85%.

**** Scale build-up will vary with mineral content in the water and amount of usage. Descaling can range from monthly to yearly maintenance.

***** The engine oil must be changed after the first 8 hours of operation and every 50 hours or 3 months, whichever comes first.

ACCESSORIES

		HSP-2003	HSP-2403	HSP-3004	HSP-3504
15-0006	SUPPLY HOSE 3/4"	•	•	•	•
50-0136	HOSE REEL 13" (HOLDS 100' OF HOSE)	•	•	•	•
50-0137	HOSE REEL 16" (HOLDS 200' OF HOSE)	•	•	•	•
50-0138	BRACKET FOR HOSE REEL (UNIVERSAL)	•	•	•	•
50-0140	BRACKET FOR HOSE REEL (22" BAR)	•	•		
852-0138	JUMPER HOSE FOR HOSE REEL (4000 PSI)	•	•	•	•
850-0174	EXTENSION HOSE 50' (3000 PSI)	•	•		
850-0199	EXTENSION HOSE 50' (4500 PSI)			•	•
AW-3005-0035	SANDBLASTER CARBIDE NOZZLE*		•		•
AW-3005-0004	SANDBLASTER CARBIDE NOZZLE *	•		•	
AW-3010-0035	SANDBLASTER CERAMIC NOZZLE *		•		•
AW-3010-0004	SANDBLASTER CERAMIC NOZZLE *	•		•	
AW-4085-0016	PUMP OIL	•	•	•	•
AW-7002-4045	ROTATING NOZZLE (.045 / 2000 max) *	•			
AW-7004-0045	ROTATING NOZZLE (.045 / 5000 max) *		•	•	•
AW-7003-1500	ROTATING BRUSH *	•	•	•	•
AW-7015-1200	EXTENSION WAND 12' ** (3000 PSI)	•	•	•	
AW-7015-1800	EXTENSION WAND 18' ** (3000 PSI)	•	•	•	
AW-7015-2400	EXTENSION WAND 24' ** (3000 PSI)	•	•	•	
AW-7020-8000	ROTARY SURFACE CLEANER** (20" 4000 PSI)	•	•	•	•
AW-7020-8001	ROTARY SURFACE CLEANER** (28" 4000 PSI)	•	•	•	•
AW-7025-8000	25" POWER BROOM (5 - 80° NOZZLES)*/***	•	•	•	•
AW-7035-8000	35" POWER BROOM (7 - 80° NOZZLES)*/***	•	•	•	•

*Requires 17-0028 1/4" female quick connect.

**Requires 17-0004 3/8" female quick connect.

***PSI and GPM must be specified when ordering.

All Purpose Cleaner, Paint Surface Prep, House & Deck Wash and Heavy Duty Degreaser are specially formulated detergents for use with all HSP pressure washers and are packaged in One (1), Five (5) and Fifty-five (55) gallon containers. Contact Customer Service Department at (800)-553-9053 for more information.



STATEMENT OF WARRANTY

Mi-T-M warrants all parts, (except those referred to below), of your new Mi-T-M HSP-Series Pressure Washer to be free from defects in materials and workmanship during the following periods:

- For Lifetime (Limited) against freezing and cracking:
 - Pump Manifold (for 1MGH/1MGV and 3MGH/3MGV Series)
- For Seven (7) Years from the date of original purchase:
 - High Pressure Pump (for 1MGH/1MGV and 3MGH/3MGV Series)
- For Three (3) Years from the date of original purchase:
 - Heat Exchanger Coil
- For One (1) Year from the date of original purchase:
 - High Pressure Pump (for 0MGH/0MGV Series)
 - Frame
 - Guard or Shields
 - Plumbing
 - Pulley
 - EMF System
- For Ninety (90) days from the date of original purchase:
 - Control Switches
 - Regulating Valve
 - Unloader Valve
 - Fuel Solenoid
 - High Limit Thermostat
 - Pressure Switch
 - Safety Switches
 - Fuel Pump
 - Electrodes
 - Safety Relief Valve
 - Temperature Switch
- For Thirty (30) day from the date of original purchase:
 - High Pressure Hose
 - Strainers / Filters
 - Trigger Gun
 - Wand

Defective parts not subject to normal wear and tear will be repaired or replaced at our option during the warranty period. In any event, reimbursement is limited to the purchase price paid.

EXCLUSIONS

1. Engine is covered under separate warranty by its respective manufacturer and is subject to the terms set forth therein.
2. Normal wear parts:
 - Pump Packings
 - Pump Valves
 - Detergent Valves
 - O-rings
 - Spray Nozzles
 - Screw Connectors/Quick Couplings
 - Fuel Filters
 - Belts
3. This warranty does not cover parts damaged due to normal wear, misapplication, misuse, operation at other than recommended speeds, pressures or temperature. Parts damaged or worn because of the use of caustic liquids or by operation in abrasive or corrosive environments or under conditions causing pump cavitation are not warranted. Failure to follow recommended operating and maintenance procedures also voids warranty.
4. The use of other than genuine Mi-T-M Repair Parts will void warranty. Parts returned, prepaid to our factory or to an Mi-T-M Authorized Service Center will be inspected and replaced free of charge if found to be defective and subject to warranty. There are no warranties which extend beyond the description of the face hereof. Under no circumstances shall Mi-T-M bear any responsibility for loss of use of the unit, loss of time or rental, inconvenience, commercial loss or consequential damages.