

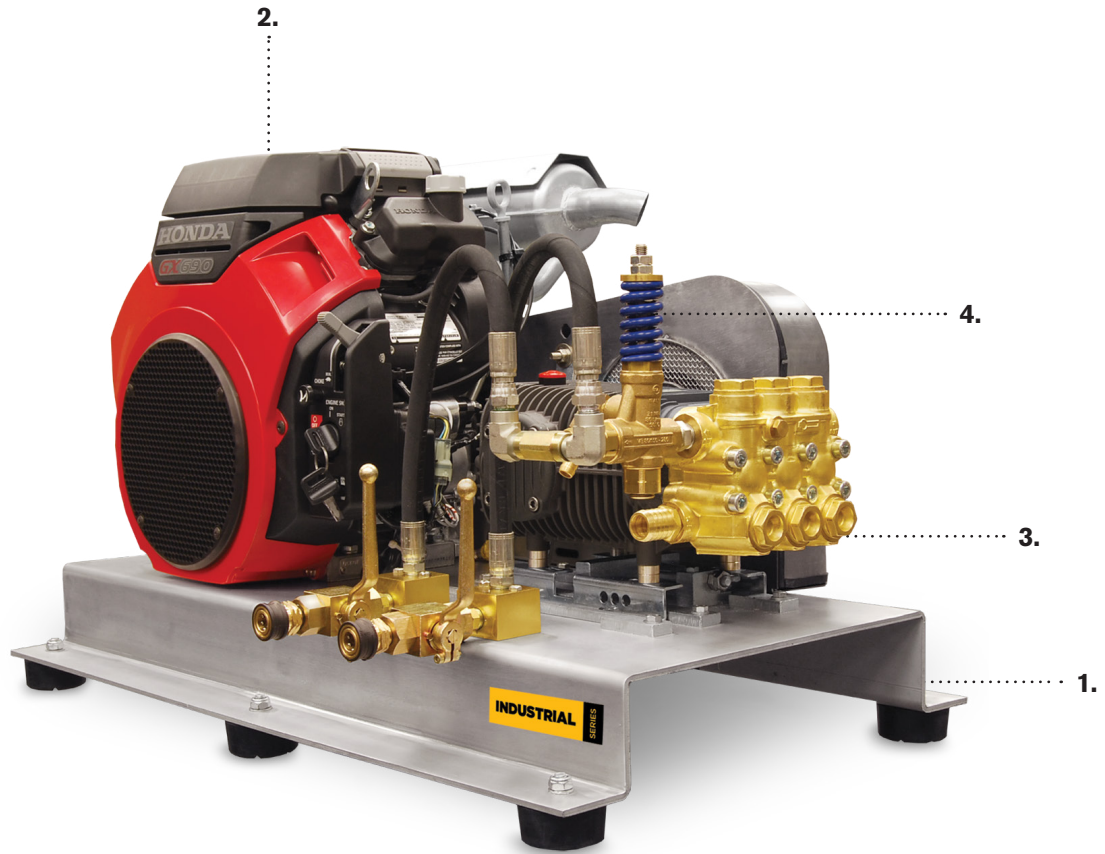

PRESSURE WASHER BREAKDOWN

CD-3024HTEBCOM



REF #	DESCRIPTION	PART #
1	Aluminum Truck Mount Frame	85.600.085
2	Engine - Honda GX690	85.510.690
3	Pump - Comet TW8030S	85.149.062
4	Unloader - VRT100	85.300.033



PRESSURE WASHER BREAKDOWN CD-3024HTEBCOM

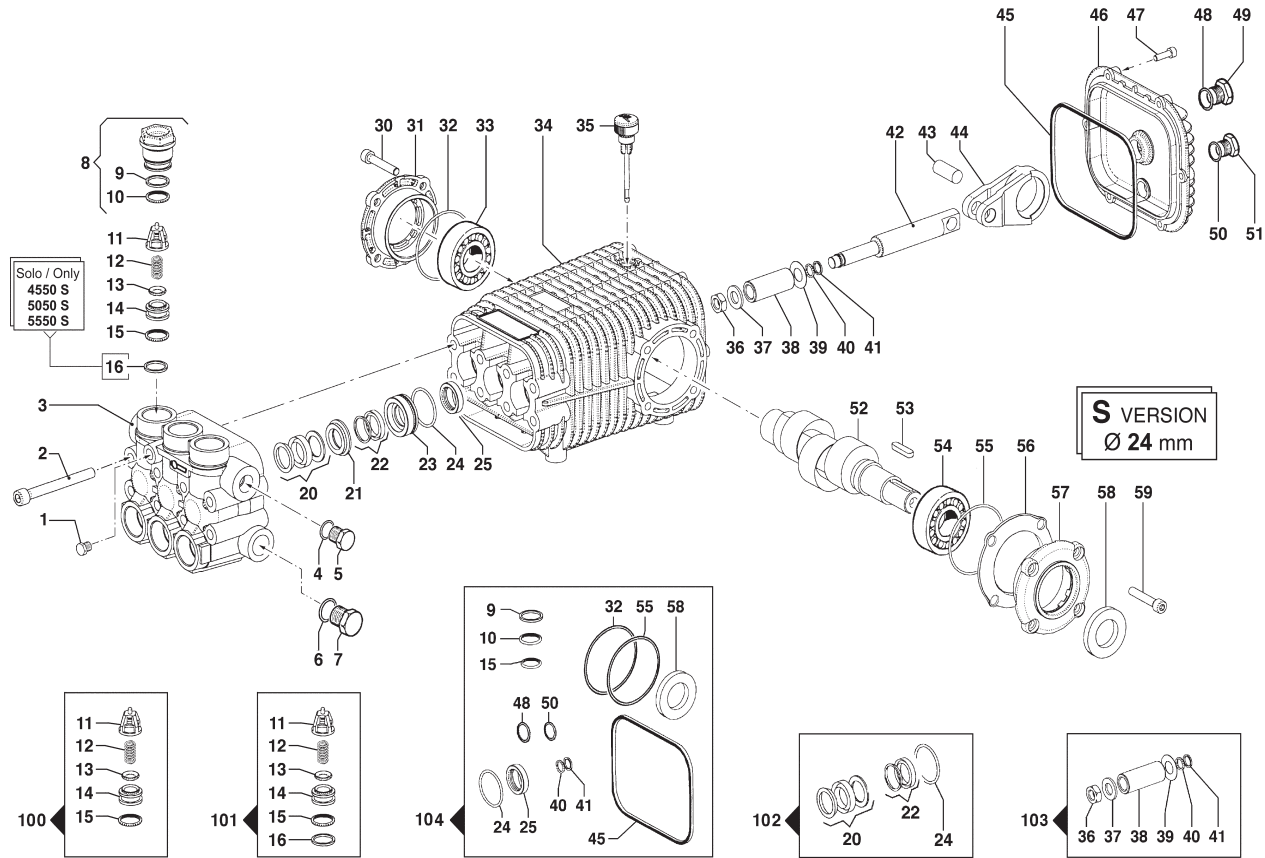

N°	Cod.	Descrizione	Description	Note	Qty	Model
1	3202 0112	Tappo	Plug	G1/4	1	
2	3609 0179	Vite	Screw	M10x100	8	
3	3218 0345	Testata Pompa	Pump Manifold	Ø18	1	4550 S - 5050 S 5550 S
	3218 0346	Testata Pompa	Pump Manifold	Ø22	1	7036 S - 8030 S 8036 S
	3218 0343	Testata Pompa	Pump Manifold	Ø25	1	10025 S - 11025 S
4	2811 0084	Rondella	Washer	Ø17x22x1,5 Allum	1	4550 S - 5050 S 5550 S
	2811 0086	Rondella	Washer	Ø21,2x27x1,5	1	7036 S - 8030 S 8036 S - 10025 S 11025 S
5	3200 0007	Tappo	Plug	3/8"	1	4550 S - 5050 S 5550 S
	3202 0015	Tappo	Plug	1/2"	1	7036 S - 8030 S 8036 S - 10025 S 11025 S
6	2811 0086	Rondella	Washer	Ø21,2x27x1,5	1	4550 S - 5050 S 5550 S
	2811 0079	Rondella	Washer	Ø27,7x32,5x1,5	1	7036 S - 8030 S 8036 S - 10025 S 11025 S
7	3202 0015	Tappo	Plug	1/2"	1	4550 S - 5050 S 5550 S
	3202 0115	Tappo	Plug	3/4"	1	7036 S - 8030 S 8036 S - 10025 S 11025 S
8	3202 0316	Kit Tappo + OR e Anello	Valve Plug Kit + OR & Ring	> 250 Bar > 3600psi	6	4550 S - 5050 S 5550 S
	3202 0317	Kit Tappo + OR e Anello	Valve Plug Kit + OR & Ring	< 250 Bar < 3600psi	6	7036 S - 8030 S 8036 S - 10025 S 11025 S

N°	Cod.	Descrizione	Description	Note	Qty	Model
9	0009 0289	Anello BK	Anti-Extr. Ring		6	4550 S - 5050 S 5550 S
	0009 0290	Anello BK	Anti-Extr. Ring		6	7036 S - 8030 S 8036 S - 10025 S 11025 S
10	1210 0021	Guarnizione OR	O-Ring	Ø2,62x15,54	6	4550 S - 5050 S 5550 S
	1210 0048	Guarnizione OR	O-Ring	Ø2,62x20,54	6	7036 S - 8030 S 8036 S - 10025 S 11025 S
11	1205 0043	Gabbia Valv. Aspir./Mand.	Suct/Delivery Valve Cage		6	4550 S - 5050 S 5550 S
	1205 0038	Gabbia Valv. Aspir./Mand.	Suct/Delivery Valve Cage		6	7036 S - 8030 S 8036 S - 10025 S 11025 S
12	1802 0177	Molla Valv. Aspir./Mand.	Suct/Delivery Valve Spring		6	4550 S - 5050 S 5550 S
	1802 0244	Molla Valv. Aspir./Mand.	Suct/Delivery Valve Spring		6	7036 S - 8030 S 8036 S - 10025 S 11025 S
13	3604 0017	Valvola Aspiraz./Mandata	Suct/Delivery Valve		6	4550 S - 5050 S 5550 S
	3604 0032	Valvola Aspiraz./Mandata	Suct/Delivery Valve		6	7036 S - 8030 S 8036 S - 10025 S 11025 S
14	3009 0144	Sede Valv. Aspir./Mand.	Suct/Delivery Valve Seat		6	4550 S - 5050 S 5550 S
	3009 0145	Sede Valv. Aspir./Mand.	Suct/Delivery Valve Seat		6	7036 S - 8030 S 8036 S - 10025 S 11025 S
15	1210 0153	Guarnizione OR	O-Ring	Ø2,62x15,08	6	4550 S - 5050 S 5550 S
	1210 0048	Guarnizione OR	O-Ring	Ø2,62x20,54	6	7036 S - 8030 S 8036 S - 10025 S 11025 S



PRESSURE WASHER BREAKDOWN CD-3024HTEBCOM

N°	Cod.	Descrizione	Description	Note	Qty	Model
16	0009 0299	Anello BK	Anti-Extr. Ring		6	Solo / Only 4550 S - 5050 S 5550 S
20	1241 0073	Guarnizione Tenuta	Packing	Ø18	3	4550 S - 5050 S 5550 S
	1241 0075	Guarnizione Tenuta	Packing	Ø22	3	7036 S - 8030 S 8036 S
	1241 0077	Guarnizione Tenuta	Packing	Ø25	3	10025 S - 11025 S
21	0009 0284	Anello Portaguarnizione	Packing Retainer	Ø18	3	4550 S - 5050 S 5550 S
	0009 0282	Anello Portaguarnizione	Packing Retainer	Ø22	3	7036 S - 8030 S 8036 S
	0009 0286	Anello Portaguarnizione	Packing Retainer	Ø25	3	10025 S - 11025 S
22	1241 0074	Guarnizione Tenuta	Packing	Ø18	3	4550 S - 5050 S 5550 S
	1241 0076	Guarnizione Tenuta	Packing	Ø22	3	7036 S - 8030 S 8036 S
	1241 0078	Guarnizione Tenuta	Packing	Ø25	3	10025 S - 11025 S
23	0009 0285	Anello Portaguarnizione	Packing Retainer	Ø18	3	4550 S - 5050 S 5550 S
	0009 0283	Anello Portaguarnizione	Packing Retainer	Ø22	3	7036 S - 8030 S 8036 S
	0009 0287	Anello Portaguarnizione	Packing Retainer	Ø25	3	10025 S - 11025 S
24	1210 0547	Guarnizione OR	O-Ring	Ø2x37	3	
25	0019 0116	Anello Tenuta	Oil Seal	Ø22x32x7	3	
30	3609 0157	Vite	Screw	M8x18	4	
31	1009 0196	Flangia	Flange		1	
32	1210 0448	Guarnizione OR	O-Ring	Ø2,0x70	1	
33	0440 0028	Cuscinetto Rulli Conici	Roller Bearing	Ø30x62x25	1	
34	0403 0155	Carter Pompa	Pump Crankcase		1	
35	3200 0075	Tappo Olio	Oil Dipstick		1	
36	0600 0054	Dado Speciale	Special Bolt		3	4550 S - 5050 S 5550 S
	0600 0062	Dado Speciale	Special Bolt		3	7036 S - 8030 S 8036 S - 10025 S 11025 S
37	2811 0082	Rondella	Washer	Ø8,4x16x1,5	3	4550 S - 5050 S 5550 S
	2811 0123	Rondella	Washer	Ø12x20x1,5	3	7036 S - 8030 S 8036 S - 10025 S 11025 S
38	0202 0042	Bussola Ceramica	Ceramic Bushing	Ø18	3	4550 S - 5050 S 5550 S
	0202 0043	Bussola Ceramica	Ceramic Bushing	Ø22	3	7036 S - 8030 S 8036 S
	0202 0044	Bussola Ceramica	Ceramic Bushing	Ø25	3	10025 S - 11025 S
39	2812 0042	Rondella	Washer		3	4550 S - 5050 S 5550 S
	2812 0083	Rondella	Washer		3	7036 S - 8030 S 8036 S - 10025 S 11025 S
40	1210 0039	Guarnizione OR	O-Ring	Ø1,78x7,66	3	4550 S - 5050 S 5550 S
	1210 0170	Guarnizione OR	O-Ring	Ø1,78x10,82	3	7036 S - 8030 S 8036 S - 10025 S 11025 S
41	0009 0170	Anello BK	Anti-Extr. Ring		3	4550 S - 5050 S 5550 S
	0009 0225	Anello BK	Anti-Extr. Ring		3	7036 S - 8030 S 8036 S - 10025 S 11025 S

N°	Cod.	Descrizione	Description	Note	Qty	Model
42	2409 0109	Pistone Guida	Piston		3	4550 S - 5050 S 5550 S
	2409 0111	Pistone Guida	Piston		3	7036 S - 8030 S 8036 S - 10025 S 11025 S
43	3011 0026	Spinotto	Gudgeon Pin	Ø14x36	3	
44	0205 0071	Biella	Connecting Rod		3	
45	1210 0349	Guarnizione OR	O-Ring	Ø3,53x142,5	1	
46	0402 0269	Coperchio Carter	Cover		1	
47	3609 0032	Vite	Screw	M6x20	6	
48	1210 0048	Guarnizione OR	O-Ring	Ø2,62x20,24	1	
49	3201 0027	Tappo	Plug	G1/2	1	
50	1210 0441	Guarnizione OR	O-Ring	Ø2x14	1	
51	3200 0007	Tappo	Plug	3/8 GAS	1	
	0001 0498	Albero Passante	Throughshaft	Ø24 mm	1	4550 S - 7036 S
52	0001 0490	Albero Passante	Throughshaft	Ø24 mm	1	5550 S - 8030 S 8036 S - 11025 S
	0001 0497	Albero Passante	Throughshaft	Ø24 mm	1	5050 S - 10025 S
53	1602 0055	Linguetta	Key	8x7x35	1	
54	0440 0028	Cuscinetto Rulli Conici	Roller Bearing	Ø30x62x25	1	
55	1210 0448	Guarnizione OR	O-Ring	Ø2,0x70	1	
56	0601 0304	Distanziale	Spacer	sp. 0,05 mm	1	
	0601 0305	Distanziale	Spacer	sp. 0,10 mm	1	
	0601 0306	Distanziale	Spacer	sp. 0,19 mm	1	
	0601 0307	Distanziale	Spacer	sp. 0,25 mm	1	
57	1009 0195	Flangia	Flange		1	
58	0019 0032	Anello Tenuta	Oil Seal	Ø30x52x7	1	
59	3609 0157	Vite	Screw	M8x18	4	

Kit Ricambi

Spare Parts Kit

N°	Cod.	Descrizione	Description	Note	Qty	Model
100	5025 0020	Kit Valvola Asp/ Mandata	Complete Valve Kit	< 250 Bar < 3600 psi	1	7036 S - 8030 S 8036 S - 10025 S 11025 S
	5025 0021	Kit Valvola Asp/ Mandata	Complete Valve Kit	> 250 Bar > 3600psi	1	4550 S - 5050 S 5550 S
102	5019 0645	Kit Guarnizioni Acqua	Water Seal Kit	Ø18	1	4550 S - 5050 S 5550 S
	5019 0646	Kit Guarnizioni Acqua	Water Seal Kit	Ø22	1	7036 S - 8030 S 8036 S
	5019 0647	Kit Guarnizioni Acqua	Water Seal Kit	Ø25	1	10025 S - 11025 S
103	2409 0116	Kit Pistone	Piston Kit	Ø18	1	4550 S - 5050 S 5550 S
	2409 0114	Kit Pistone	Piston Kit	Ø22	1	7036 S - 8030 S 8036 S
	2409 0115	Kit Pistone	Piston Kit	Ø25	1	10025 S - 11025 S
104	5019 0644	Kit Guarnizioni Olio	Oil Seal Kit	< 250 Bar < 3600 psi	1	7036 S - 8030 S 8036 S - 10025 S 11025 S
	5019 0649	Kit Guarnizioni Olio	Oil Seal Kit	> 250 Bar > 3600psi	1	4550 S - 5050 S 5550 S



PRESSURE WASHER BREAKDOWN CD-3024HTEBCOM

COMPONENT & CONTROL LOCATION

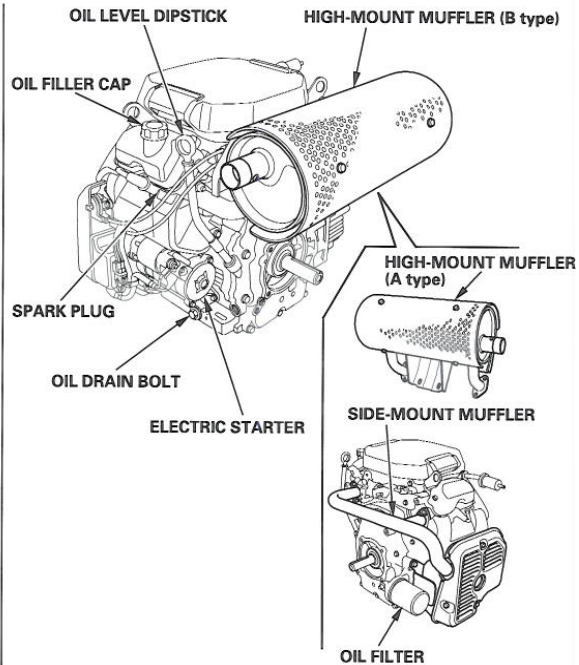
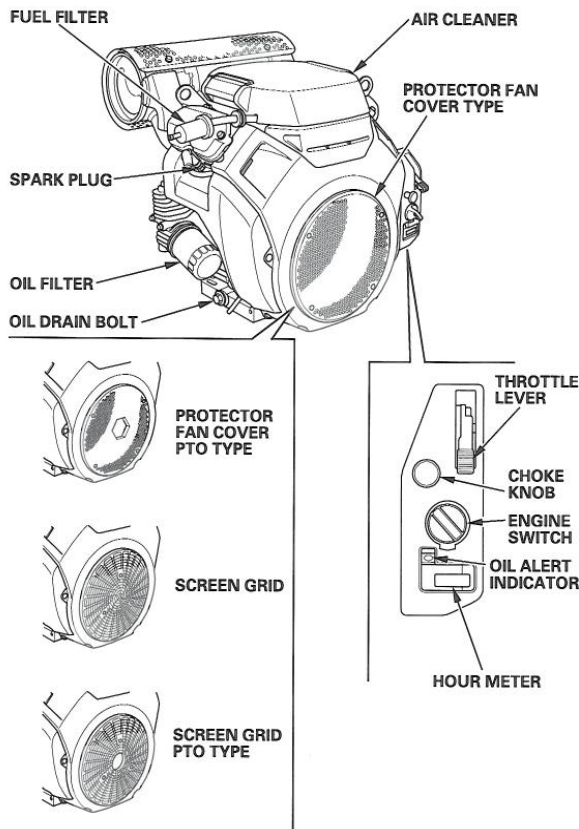

FEATURES

Oil Alert® System (applicable types)

"Oil Alert is a registered trademark in the United States"

The Oil Alert system is designed to prevent engine damage caused by an insufficient amount of oil in the crankcase. Before the oil level in the crankcase can fall below a safe limit, the Oil Alert indicator (red) comes on and the Oil Alert system will automatically stop the engine (the engine switch will remain in the ON position).

If the engine stops and will not restart, check the engine oil level (see page 8) before troubleshooting in other areas.

Hour Meter

After starting the engine, the elapsed time of the engine in use will be count. It will not count the elapsed time of the engine operation by just turning the engine switch ON.

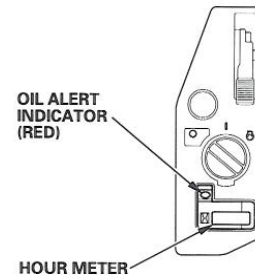

Fuel-cut Solenoid

The engine is equipped with a fuel-cut solenoid that allows fuel to flow to the carburetor main jet when the engine switch is in the ON or START position and stops the flow of fuel to the main jet when the engine switch is in the OFF position.

The engine must be connected to the battery to energize the fuel-cut solenoid, allowing the engine to run. If the battery is disconnected, fuel flow to the carburetor will stop.