

FEATURES

Triples Plunger Pump w/ Unloader and Downstream Injector

- Forged brass manifold with exclusive lifetime warranty
- Over-sized connecting rods for ultimate crankcase performance
- Die-cast anodized aluminum, oil-bath crankcase
- Solid ceramic plungers with continuously lubricated packings
- The original Interpump unitized, stainless steel, K01 inlet and outlet valves
- Ideal for all general cleaning applications
- Comes standard with either SAE J609 gasoline engine mounting flange, or NEMA 56C mounting flange
- Also available in "L" left-handed versions



SPECIFICATIONS

Pump Model	TP2520J34UIL	TP2526J34UIL	TP2530J34UIL	TP2533J34UIL
Maximum Volume	1.9 GPM	2.6 GPM	2.88 GPM	3.3 GPM
Maximum Discharge Pressure	2500 PSI			
Maximum Pump Speed	3400 RPM			
Maximum Inlet Pressure	125 PSI			
Maximum Inlet Vacuum	3 ft. water (2.6 Hg)			
Plunger Bore (in / mm)	.591 / 15			
Plunger Stroke (in / mm)	.197 / 5	.260 / 6.6	.283 / 7.2	.315 / 8
Crankcase Oil Capacity	11.0 oz.			
Maximum Fluid Temperature	165°F			
Pump Inlet Port Thread	3/8-19 BSPP-F			
Unloader Inlet Port Thread	1/2-14 BSPP-F**			
Pump Discharge Port Thread	1/4-19 BSPP-F			
Unloader Discharge Port Thread	3/8-19 BSPP-M			
Hollow Shaft I.D.	3/4 in. / 19 mm			
Weight	11.4 lbs.			
Dimensions	7.0" x 7.2" x 5.5"			

DIMENSIONAL DRAWING

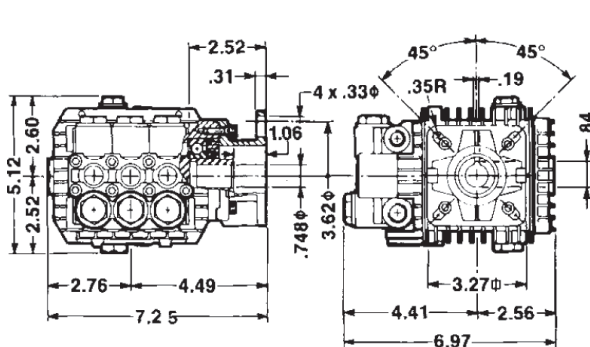

J34 Version

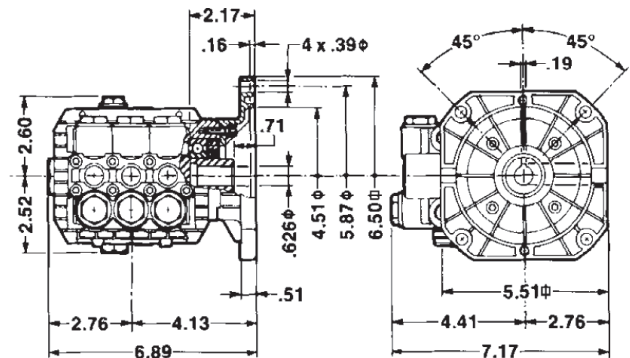

X34 Version



General Pump
is a member of
the Interpump Group



TRIPLEX

TRIPLEX

TP Series 51

GENERAL PUMP *A member of the Interpump Group*

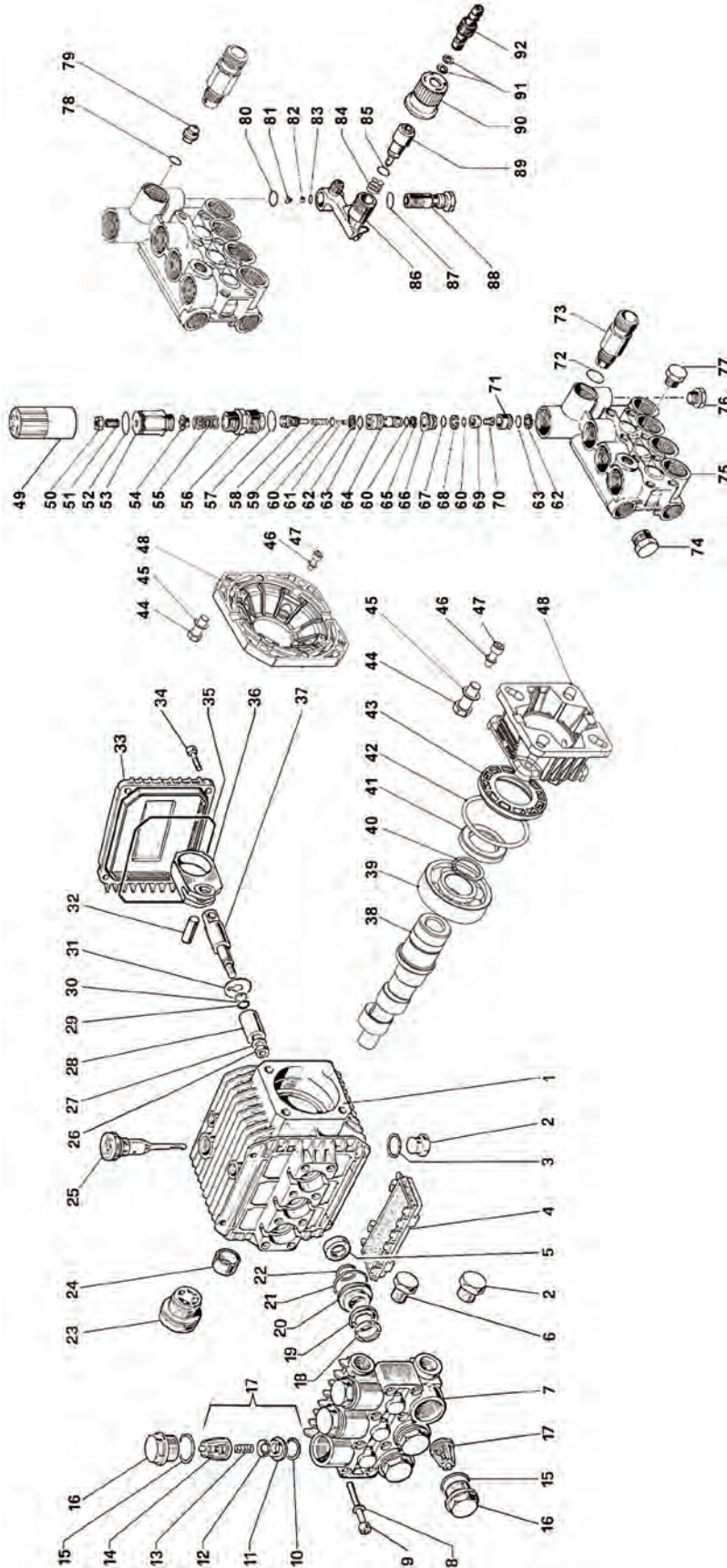

TP Series 51

GENERAL PUMP *A member of the Interpump Group*

PARTS LIST

Item	Part #	Description	QTY.
1	51010622	Crankcase	1
2	98210000	Plug, 3/8 x 13	2
3	90383300	O ring, Ø 13.95 x 2.62	1
4	51209051	Protector	1
5	90156500	Oil Seal	3
6	98204100	Plug, G1/4" x 9	1
8	96693800	Washer, Ø 6.4 x 10 x 0.7	8
9	99194300	Screw, M6 x 40	8
10	90384100	O ring, Ø17.13 x 2.62	6
11	36200366	Valve Seat	6
12	36200176	Valve Plate	6
13	94737600	Spring, Ø 9.4 x 14.8	6
14	36202551	Valve Cage	6
15	701002	O ring, 20.24 x 2.62	6
16	98221600	Valve Cap, M24 x 1.5 x 11.2	6
17	36711501	Valve Assembly	6
18	51100051	Head Ring	3
19	90262000	Packing	3
20	51080070	Packing Retainer	3
21	90360400	O ring, Ø 25.12 x 1.78	3
22	90383500	O ring, Ø 15.08 x 2.62	3
23	97596800	Oil Site Glass	1
24	91801400	Needle Bearing	1
25	98210300	Oil Dipstick	1
26	92221600	Nut, M8 x 13 x 5	3
27	44211570	Bushing, Ø 8	3
28	51040009	Plunger (15 mm)	3
29	90357300	O ring, Ø 5.28 x 1.78	3
30	660024	Anti extrusion Ring, Ø 6.2 x 9x 1.5	3
31	96707000	Flinger Washer, Ø 9 x 23 x 0.5	3
32	97731000	Connecting Rod Pin, Ø 8 x 24.5	3
33	51160022	Crankcase Cover	1
34	99186700	Screw, M6 x 18	4
35	90391700	Gasket, Ø 88.57 x 2.62	1
36	51030122	Connecting Rod	3
37	51050056	Plunger Guide	3
38	51021065	Crankshaft, TP2530	1
	51021165	Crankshaft, TP2526	1
	51022165	Crankshaft, TP2530	1
	51021865	Crankshaft, TP2533	1
39	20283521	Bearing	1
40	90066700	Snap Ring	1
41	90164400	Oil Seal	1
42	90409700	O ring, Ø 55.56 x 3.53	1
43	50211551	Spacer	1
44	99273000	Screw, 5/16" x 3/4" x 24 (J34)	4
	99334500	Screw, 3/8" x 16 (X34)	4
45	96701400	Washer	4
46	96693800	Washer	4
47	99186700	Screw, M6 x 18	4
48	10034622	Flange, J34	1
	10034422	Flange, X34	1
49	36318751	Pressure Regulation Knob	1

Item	Part #	Description	QTY.
50	92221800	Nut	1
51	99305400	Screw, Set, Socket, Headless, M8 x 20	1
52	701109	O ring, Ø 20.35 x 1.78	1
53	36318570	Pressure Set Screw	1
54	36316970	Spring Plate	1
55	94743600	Spring, Ø 15 x 35	1
56	36318470	Guide Bushing	1
57	701002	O ring, Ø 20.24 x 2.62	1
58	36318870	Stroke Stopper	1
59	94733200	Spring, Ø 6.1 x 19	1
60	90357500	O ring, Ø 6.75 x 1.78	3
61	36333151	Shutter	1
62	90506500	Anti extrusion Ring, Ø 10.6 x 15 x 2	2
63	701614	O ring, Ø 9.92 x 2.62	2
64	36318970	Control Piston	1
65	90502500	Anti extrusion Ring, Ø 7 x 10 x 1.5	1
66	36316570	Valve Guide	1
67	701014	O ring, Ø 12.42 x 1.78	1
68	90507500	Anti extrusion Ring, Ø 13 x 16 x 1.5	1
69	36319066	Spherical Valve	1
70	99150900	Screw, M5 x 0.8 x 8.5	1
71	36316466	Valve Seat	1
72	90383200	O ring, 13.95 x 2.62	1
73	10007870	Nipple, 3/8 BSPP M	1
	10014770	Nipple, M22 M	OPT
	10031870	Nipple, 3/8 NPT F	OPT
74	98204100	Plug, 1/4 x 9	1
75	51120141	UI Manifold	1
76	98205700	Plug, M14 x 5	1
77	98204100	Plug, 1/2 x 9	1
78	701614	O ring, 9.92 x 2.62	1
79	10015166	Nozzle, 2mm	1
80	701012	O ring, Ø 9.25 x 1.78	1
81	94821700	Taper Spring, Ø 4.3 x 7.6 x 11	1
82	97478200	Ball, Ø 7/32"	1
83	701501	O ring, Ø 5.28 x 1.78	1
84	94738300	Spring, Ø 9.75 x 10	1
85	701612	O ring, Ø 8.73 x 1.78	1
86	36318151	Injector Body	1
87	701013	O ring, Ø 10.82 x 1.78	1
88	36256370	Chemical Valve Seat	1
89	36256470	Injector Shutter End	1
90	36256551	Chemical Regulation Knob	1
91	701008	O ring, Ø 4.48 x 1.78	2
92	36256670	Hose Barb Coupling	1

REPAIR KITS

KIT NO.	83	86	94	96	97	102	123
ITEM NO's INCLUDED IN KIT	5	20, 21, 22	72, 78, 80, 81, 82, 83, 84, 85, 87, 91	18, 19, 20, 21, 22	18, 19, 21, 22	56, 57, 68, 59, 60, 61, 62, 63, 64, 65, 66, 67, 68, 69, 70, 71	10, 11, 12, 13, 14, (17)
NUMBER OF ASSEMBLIES IN KIT	3	3		1	3		6
NUMBER OF CYLINDERS KIT WILL SERVICE	3	3		1	3		3

TORQUE SPECS*

Position	Ft. Lbs.	Nm
2	29.5	40
6	14.8	20
9	8.9	12
16	59	80
23	14.8	20
34	7.4	10
39	7.4	10
47	7.4	10
56	36.9	50
58	5.9	8
70	1.5	2
73	29.5	40
74	14.8	20
76	14.8	20
77	14.8	20

