

FEATURES

- Built-in Pressure Trapping Unloader and Injector
- Next Generation Packings for Exceptional Seal Life
- Solid White Ceramic Plungers
- Direct-Drive for Convenience and Durability
- Oversized Connecting Rods

**SPECIFICATIONS***

Pump Model	TX1508G8UIA	TX1509G8UIA	TX1510G8UIA
Maximum Volume	3.0 GPM	3.5 GPM	4.0 GPM
Maximum Pressure	3500 PSI		
Maximum RPM	3400 RPM		
Maximum Inlet Pressure	125 PSI		
Minimum Inlet Pressure	3 ft (2.6 in Hg)		
Maximum Fluid Temperature	165° F		
Bore (in / mm)	.591 in / 15mm		
Stroke (in / mm)	.315 in / 8 mm	.355 in / 9 mm	.394 in / 10 mm
Oil Capacity	14.0 oz		
Inlet Port Thread	1/2"-NPT-M		
Discharge Port Thread	3/8"-NPT-M		
Shaft Diameter	1" - Hollow		
Motor Flange	J609-b		
Weight	18.2 lb		
Dimensions-Inches-Nominal	10.1 x 9.6 x 10.4		

*Dimensions and/or specifications subject to change without notice

TX Series 63 UI

Direct Drive Triplex Plunger Pump

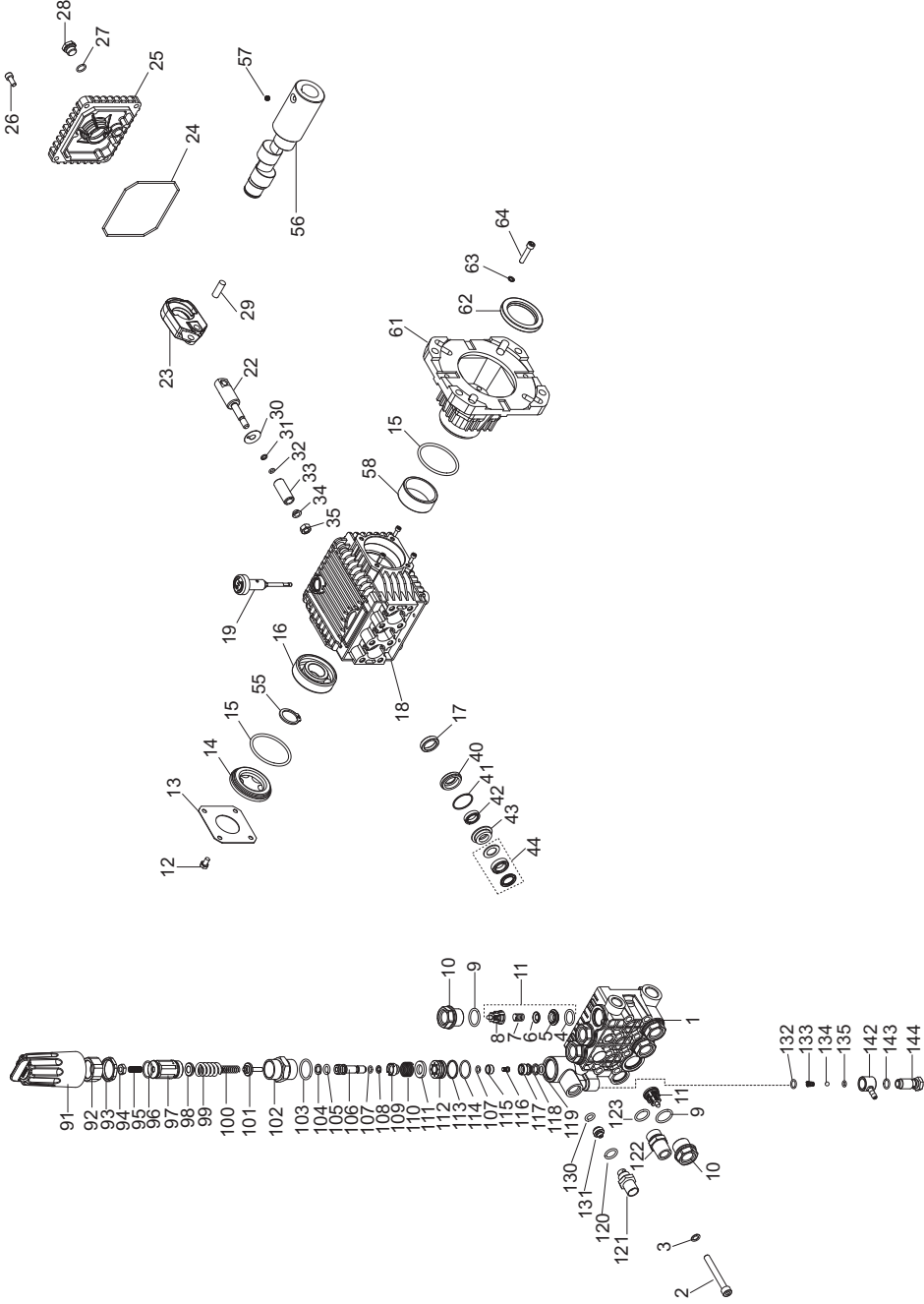

REPAIR KITS

Kit. No.	K123	K124	K159	K160	K162	K164	K166	K137	K235	K236	K237
Items Included In Kit	4 - 8 (11)	9, 10	17	42, 44	40	43	40 - 44	104 - 119	91 - 103	91 - 119	132 - 144
Pc. In Kit	6	6	3	3	3	3	1	1	1	1	1

TORQUE SPECS*

Item	Ft/lb	Nm
2	14.7	20
10	95.9	130
12	7.3	10
26	7.3	10
28	14.7	20
35	11.0	15
64	7.3	10
121	29.5	40
122	29.5	40

*Decrease torque by 20% if threads are lubricated.



PART LIST

Item	Part no.	Description	Qty	Item	Part no.	Description	Qty	Item	Part no.	Description	Qty
1	63120741	Manifold, 15 mm, LH, NPT	1	43	63216070	Int. Ring, 15mm	3	111	36323151	Valve	1
2	99319200	Screw, M8 x 65	8	44	90261200	Packing Assy, 15mm	3	112	36322970	Valve guide	1
3	96701400	Lockwasher, M8.4	8	55	90063500	Retaining Ring	1	113	90360000	O-ring	1
4	701115	O-ring	6	56	63028065	Crankshaft, 8mm (1")	1	114	90514400	Anti-Ext ring	1
5	36200366	Valve Seat	6		63028265	Crankshaft, 9mm (1")	1	115	36319066	Spherical valve	1
6	36200176	Valve Plate	6		63028465	Crankshaft, 10mm (1")	1	116	99150900	Screw	1
7	94737600	Spring	6	57	99179000	Screw, M6 x 6	1	117	36316466	Seat	1
8	36202551	Valve Cage	6	58	91856800	Roller bearing	1	118	701614	O-ring	1
9	701002	O-ring	6	61	10051822	Flange 1", gas engine	1	119	90506500	Anti-Ext ring	1
10	98222600	Valve Cap	6	62	90169000	Oil Seal	1	120	90383200	O-ring	1
11	36711501	Valve Assembly	6	63	96693800	Washer	4	121	10065170	Nipple, Disch - 3/8"NPT-M	1
12	99180700	Screw, M6 x 10	8	64	99191200	Screw, M6 x 30	4	122	36333370	Inlet Fitting	1
13	50150074	Bearing Cover	1	91	36322151	Handle (Black)	1	123	90384100	O-ring	1
14	44211801	Oil Level Indicator	1	92	36318670	Locking sleeve	1	130	701614	O-ring	1
15	90409700	O-ring	2	93	92293500	Locking nut	1	131	10007666	Nozzle 2.2mm	1
16	91833100	Ball Bearing	1	94	92221800	Nut	1	132	701012	O-ring	1
17	90159500	Oil Seal	3	95	99305400	Set screw	1	133	94821700	Conical spring	1
18	63010022	Crankcase	1	96	701019	O-ring	1	134	97478200	Ball	1
19	98210300	Oil Dip Stick	1	97	36318570	Regulator knob	1	135	701501	O-ring	1
22	63050066	Plunger Guide	3	98	36316970	Spring seat	1	142	36260451	Fixed Injector	1
23	63030022	Connecting Rod	3	99	94743800	Spring (3500 PSI)	1	143	701013	O-ring	1
24	90392000	O-ring, Cover	1	100	94734500	Spring	1	144	36256370	Banjo bolt, Injector	1
25	63160122	NEW Rear Crankcase Cover	1	101	36323370	Stem	1				
26	99183700	Screw, M6 x 14	4	102	36322870	Guide bushing	1				
27	701013	O-ring	1	103	90385700	O-ring	1				
28	98204100	Plug, 1/4" G	1	104	90505200	Anti-Ext ring	1				
29	97733500	Connecting Rod Pin	3	105	90382000	O-ring	1				
30	96707500	Flinger Washer	3	106	36323470	Sleeve	1				
31	660024	Anti-extrusion Ring	3	107	90357500	O-ring	2				
32	701009	O-ring	3	108	90502500	Anti-Ext ring	1				
33	52040009	Ceramic Plunger, 15mm	3	109	36323070	Spacer	1				
34	44211570	Bushing	3	110	94748500	Spring	1				
35	92221600	Nut, M8	3								
40	63080070	Seal Retn'r, 15mm	3								
41	90360800	O-ring	3								
42	90260800	Seal, LP, 15mm	3								



TX Series 63 UI

Direct Drive Triplex Plunger Pump

DIMENSIONS* (INCHES)

J609b Models

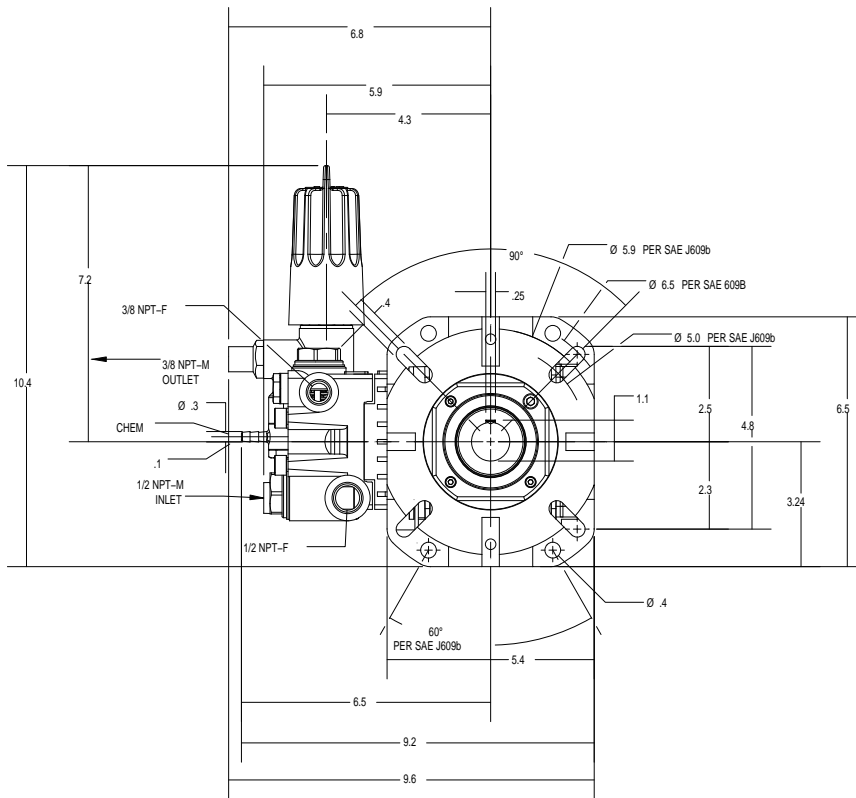
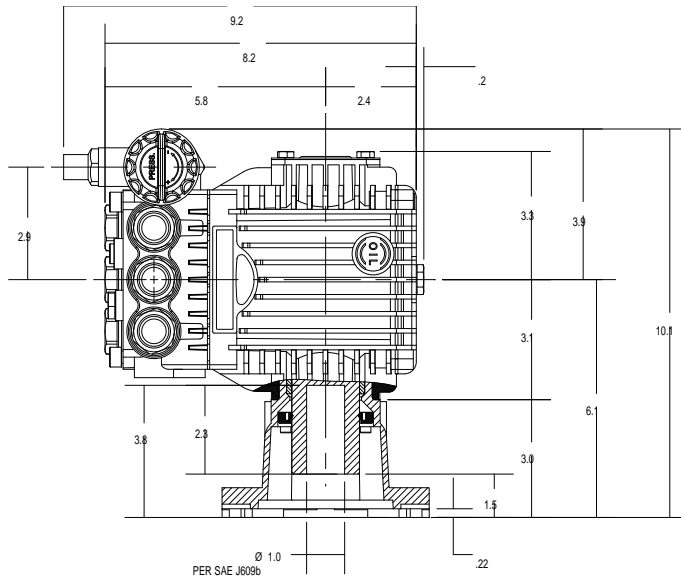

TX1510G8UIA