

## FEATURES

- Designed and engineered exclusively for pressure washers.
- Seven year limited warranty.
- Forged brass manifold with an exclusive lifetime warranty.
- Large capacity, die-cast, anodized aluminum oil-bath crankcase.
- Aluminum two piece connecting rods with lubrication channels for maximum life.
- Heavy-duty crankshaft bearings.
- Solid ceramic plungers with mirror finish and corrosion resistance.
- Long life seals.
- Stainless steel inlet and discharge valve assemblies.
- Forged valve caps with recessed O-rings to withstand high pressures.
- Dacromet® coated manifold bolts for extra corrosion resistance.
- Precision oil dipstick for proper ventilation of crankcase.
- Flanged for direct couple to electric motor (56C).



## SPECIFICATIONS

PUMP MODEL	KE2020F.1	KE2020S.1	KE2825F.1	KE2825S.1	KE3525F.1
Maximum Volume (GPM)	2	2	2.8	2.8	3.5
Max. Discharge Pressure (PSI)	2000	2000	2500	2500	2500
Maximum Pump Speed	3400	1725	3400	1725	3400
Maximum Inlet Pressure	125 psi				
Maximum Inlet Vacuum	Flooded				
Bore	15 mm	18 mm	15 mm	18 mm	15 mm
Stroke	4.6 mm	5.6 mm	7.0 mm	8.4 mm	8.8 mm
Crankcase Oil Capacity	14 oz.				
Maximum Fluid Temperature	185°F				
Inlet Port Thread	1/2-14 BSPP-F				
Discharge Port Thread	3/8-19 BSPP-F				
Shaft Diameter	5/8" Hollow				3/4" Hollow
Weight	17 lbs.				
Dimensions (LxWxH)	8.5 x 7.5 x 6.5 in.				

# KE.1 Series Pump

9.803-814.0 KE 2020F.1  
 9.803-815.0 KE 2020S.1  
 9.803-816.0 KE 2825F.1  
 9.803-817.0 KE 2825S.1  
 9.803-818.0 KE 3525F.1

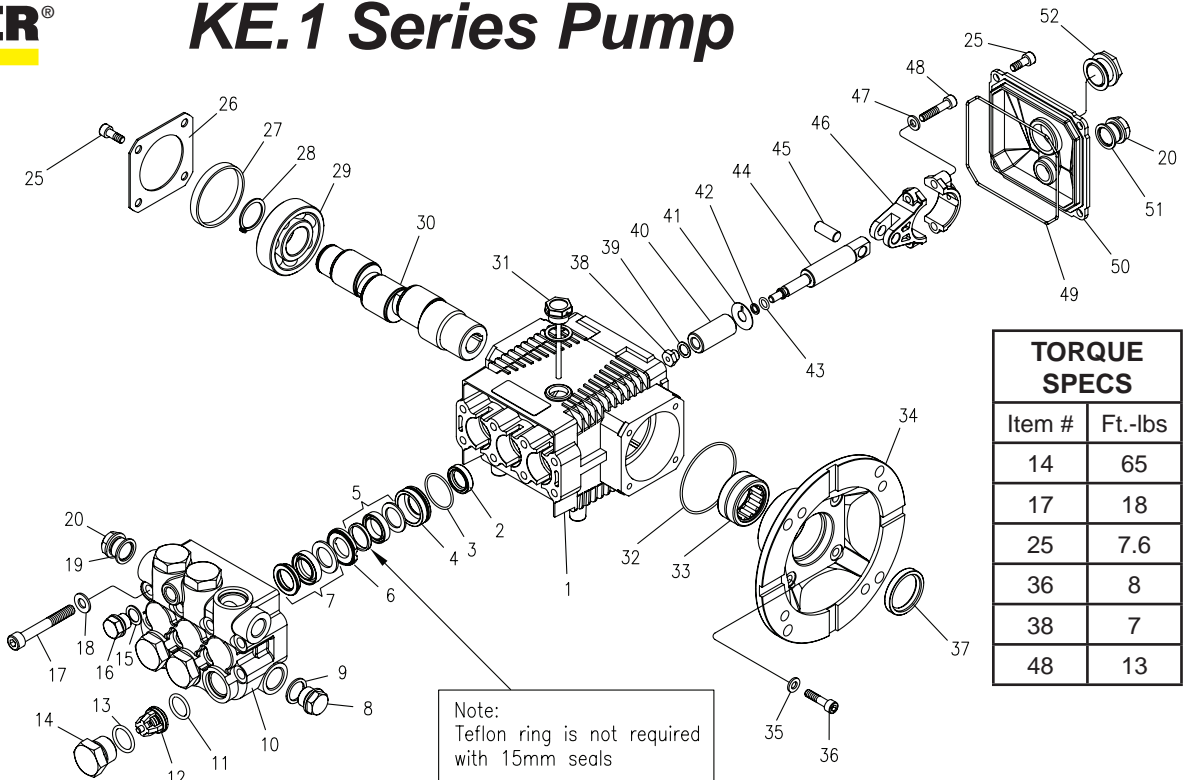

## PARTS LIST

ITEM	PART NO.	DESCRIPTION	QTY	ITEM	PART NO.	DESCRIPTION	QTY	ITEM	PART NO.	DESCRIPTION	QTY
1	9.803-938.0	Crankcase	1	16	9.803-951.0	Brass Plug G1/4	1	36	9.804-584.0	Flange Screw	4
2*	9.804-586.0	Plunger Oil Seal	3	17	9.803-952.0	Manifold Stud Bolt	8	37	9.804-585.0	Crankshaft Seal	1
3*	See Kit Below	O-Ring Ø 1.78 x 28.30	3	18	9.802-884.0	Washer	8	38*	See Kit Below	Plunger Nut	3
4*	See Kit Below	Pressure Ring 15mm	3	19	9.803-198.0	Copper Washer 3/8	1	39*	See Kit Below	Copper Spacer	3
	See Kit Below	Pressure Ring 18mm	3	20	9.802-925.0	Brass Plug G3/8	2	40*	See Kit Below	Plunger 15mm (2020F, 2825F, 3525F)	3
5*	See Kit Below	U-Seal, dia 15mm	6	25	9.802-939.0	Screw	12		See Kit Below	Plunger 18mm (2020S, 2825S)	3
	See Kit Below	U-Seal, dia 18mm	6	26	9.803-953.0	Bearing Cover	2	41*	See Kit Below	Copper Spacer	3
6*	See Kit Below	Intermediate Ring 15mm	6	27	9.803-954.0	Bearing Seal	1	42*	See Kit Below	O-Ring Ø1.78 x 5.28	3
	See Kit Below	Intermediate Ring 18mm	6	28	9.802-914.0	Snap Ring	1	43*	See Kit Below	Teflon Ring	3
7*	See Kit Below	U-Seal, 15mm	3	29	9.803-955.0	Ball Bearing	2	44	9.803-964.0	Plunger Rod	3
	See Kit Below	U-Seal, 18mm	3	30	9.804-576.0	Crankshaft (2020F)	1	45	9.803-965.0	Connecting Rod Pin	3
8	9.802-926.0	Brass Plug G1/2	1		9.804-577.0	Crankshaft (2020S)	1	46	9.803-966.0	Connecting Rod	3
9	9.803-199.0	Copper Washer 1/2"	1		9.804-578.0	Crankshaft (2825F)	1	47	9.803-218.0	Spring Washer	6
10	9.803-946.0	Manifold Housing	1		9.804-579.0	Crankshaft (2825S)	1	48	8.933-020.0	Connecting Rod Screw	6
11	9.803-947.0	O-Ring Ø1.78 x 15.54	6		9.804-580.0	Crankshaft (3525F)	1	49	9.803-969.0	O-Ring Ø2.62 x 107.62	1
12*	See Kit Below	Valve Assembly	6	31	9.803-957.0	Oil Dipstick	1	50	9.803-968.0	Crankcase Cover	1
13*	9.803-948.0	O-Ring Ø2.62 x 18.77	6	32	9.804-581.0	O-Ring Ø3.53 x 55.56	1	51	9.803-197.0	Gasket	1
14	9.803-949.0	Valve Plug	6	33	9.804-582.0	Needle Bearing	1	52	9.803-202.0	Sight Glass	1
15	9.803-950.0	Copper Washer 1/4	1	34	9.804-583.0	Motor Flange 56C	1				
				35	9.803-210.0	Washer	4				

## REPAIR KITS

REPAIR KIT NUMBER	8.725-354.0	8.725-356.0	8.725-355.0	8.725-357.0	9.803-934.0	9.803-935.0	9.803-936.0	9.803-937.0
KIT DESCRIPTION	Plunger Seal 15mm 2020F.1 2825F.1 3525F.1	Plunger Seal 18mm 2020S.1 2825S.1	Complete Seal Packing 15mm 2020F.1 2825F.1 3525F.1	Complete Seal Packing 18mm 2020S.1 2825S.1	Plunger 15mm 2020F.1 2825F.1 3525F.1	Plunger 18mm 2020S.1 2825S.1	Complete Valve	Plunger Oil Seals
ITEM NUMBERS INCLUDED	3, 5, 7	3, 5, 7	3, 4, 5, 6, 7	3, 4, 5, 6, 7	38, 39, 40, 41, 42, 43	38, 39, 40, 41, 42, 43	11, 12, 13	2
NO. OF CYLINDERS KIT WILL SERVICE	3	1	1	1	1	1	6	3