

Assembly instructions

⚠ (This instruction is valid for the base model as well as for the resulting versions)

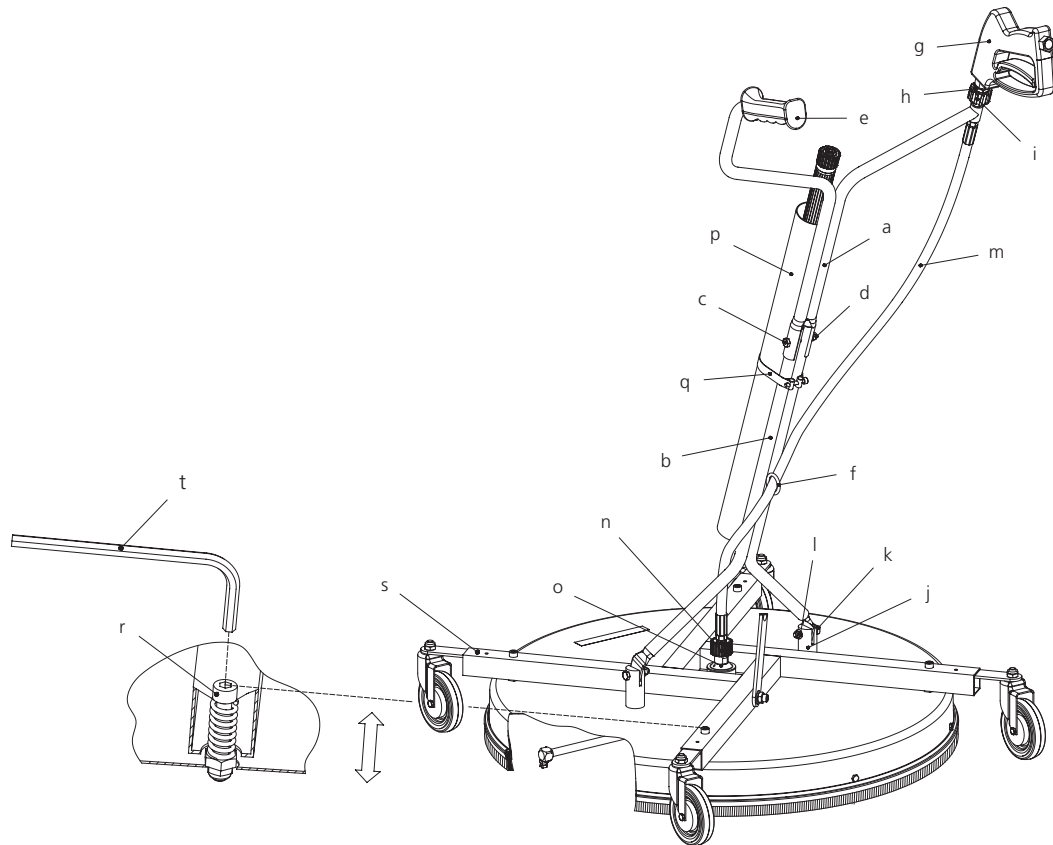

1. Slide the upper fork (a) over the lower fork (b). Secure the two forks with the bolt (c) and the safety nut (d).
- ⚠ Note: the handle (e) and the ring (f) point in the same direction.
2. Connect the HP-gun (g) with the preinstalled adapter (h) to the quick connect (i).
 3. Install the assembled fork (a+b) with the two bolts (k) and the two safety nuts (l) onto the fork holder (j). Works best if handle is in vertical position.
 4. Connect the HP hose (m) with the quick connect (n) to the swivel (o).
 5. Install the wand holder (p) by using the pipe clamp (q) onto the lower fork (b).
- ⚠ Note: Adjust the bolts (r) of the wheel suspension (s) up or down for the ideal cleaning distance with the provided hexagon socket wrench (t).

⚠ For your own safety

- Read all instructions before the initial operation. Check their proper condition and that they operate safely.
- Always use protection gear when using products connected to high pressure.
- Before any maintenance or nozzle-change, turn off the high pressure water supply, e.g.: turn off and secure the power switch.
- After turning off the system, allow all self propelled equipment to come to a complete stop before handling.
- Safety regulations and guidelines (Accident Prevention Rules) from the manufacturer of your high pressure cleaner are applicable.
- Nozzle installation according to nozzle manufacturer.
- Do not move the unit over objects or uneven surfaces.
- Do not lift up the unit while operating.
- Do not run the unit if spray-arm is out of balance or bent, damage to the swivel will result.
- No modifications to the unit are permitted.

Spare parts List

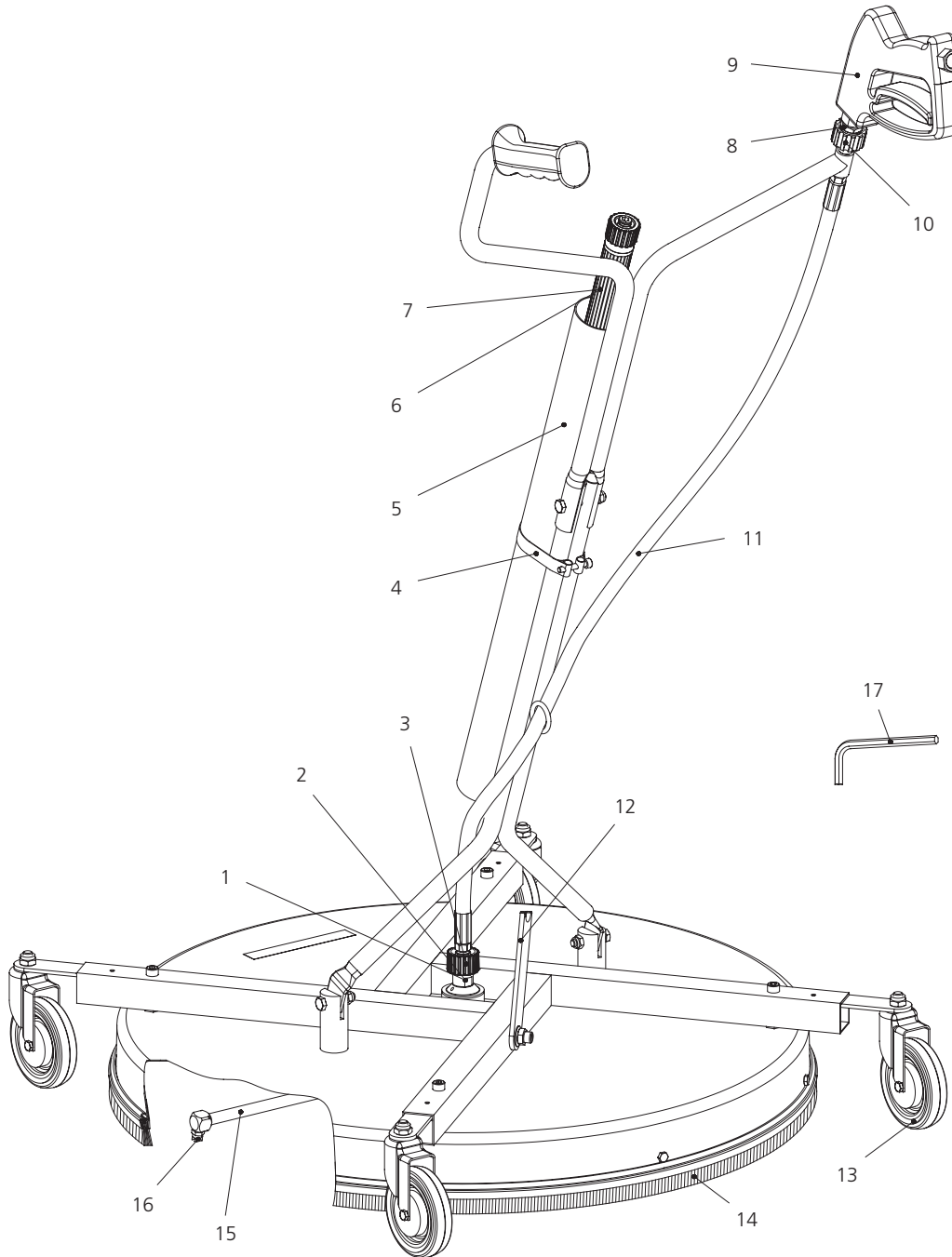

Pos.	Part No.	Description	
1	55.253	Swivel DYC	
2	36.906	Carbide seal-kit	
3	50.155	Quick-connect	M22-F - G1/4"F
4	902.113	Pipe clamp	
5	902.116	Wand holder	Dia. 2 1/4" x 22"
6	26.994	HP-wand	
7	1508	HP-nozzle 1508	
8	51.278	Adapter	M22-M - 1/4"NPT-M
9	29.081	HP-gun 4000 psi	
10	50.903	Quick-connect	M22-F - G1/4"M
11	901.953	HP-hose	G1/4"M - G1/4"M
12	902.647	Support	
13	80.956	Stainless steel castor	
14	901.662	Brush ring	
15	82.943	Turbo-rotor-arm	Dia. 27,5"
16	1503	HP-nozzle 1503	
17	901.950	Hexagon socket wrench 6mm	