



14.5001 PF22 Professional Foam Lance - Users Manual

The PF22 Professional Foam Lance combines a high pressure water flow mixed with detergent and air to produce thick clinging foam. With the adjustable intake you can increase or decrease the amount of detergent drawn into the water flow adjusting the amount of foam created. Furthermore, the PF22 Professional Foam Lance has a variable angle spray pattern that with a simple twist goes from a 0 degree focused jet to 50 degree fan pattern.

Product's Use

A pressure washer with a minimum of 1.8 GPM flow and 1,100 PSI is required for the product to operate correctly.

Use fresh clear water, with common detergents. We recommend that any impure fluid be adequately filtered before it is used. Detergents with suspended particles can clog the filter and the product will fail to operate properly.

MTM Hydro, Inc. does not manufacture or supply any of the chemicals used with our product and is not responsible for their effects. Because of the large number of chemicals that could be used (and their different chemical reactions), the buyer and user of this equipment should determine compatibility of the materials used and any of the potential hazards involved.

NOTE: Always remember to carefully read the chemical manufacturer's label and follow all directions.

****** AFTER EVERY USAGE PRIOR TO STORAGE, RINSE AND THOROUGHLY FLUSH WITH CLEAR WATER. FAILURE TO THOROUGHLY RINSE AND FLUSH CHEMICALS WILL CAUSE THE FILTER TO CLOG AND THE PRODUCT WILL FAIL TO OPERATE PROPERLY. THIS FAILURE CAN OCCUR AFTER THE FIRST USE. ******

1.Remove 1 litre bottle

2.Pull trigger on spray gun

3.Allow clean clear water to thoroughly flush out chemicals in filter for a few minutes

WARNING: Check to ensure that the product is compatible with the system's operating specifications do not exceed the maximum flow, pressure, and temperature ratings of the product that are listed in this manual (see Technical Chart).

Installation must be done exclusively by skilled workers. The Manufacturer is not responsible or liable for any loss or damage arising from improper installation or installation done by unskilled workers.

Service

Service must be done exclusively by skilled workers using only original MTM Hydro replacement parts.

To correctly reassemble, follow the drawing listed in the exploded view in this manual.

WARNING: The components need to be properly reassembled to restore the original conditions of the product. The Manufacturer is not responsible or liable for any loss or damage arising from improper reassembly or service by unskilled workers.

Further Instructions

To correctly install, use, and service this product, carefully read and follow the instructions and warnings contained in this manual. Ensure these instructions are included in the final user's manual of any machine in which the product is assembled.

Any improper use of or alteration of this product may cause loss or injury. The Manufacturer is not responsible or liable for any loss, damage, or injury arising from improper use or alteration and declines all liability for its functioning and safety.

The product described here complies with the rules and the lines in force that you can find in the MTM Hydro, Inc. CONFORMITY DECLARATION.

MTM Hydro declines all responsibility and liability in the case that the compliance and regulations stated in this manual are not followed or respected.

MTM Hydro reserves the right to make any modification to both products and manuals without notice.

14.5001 PF22 Professional Foam Lance Components List

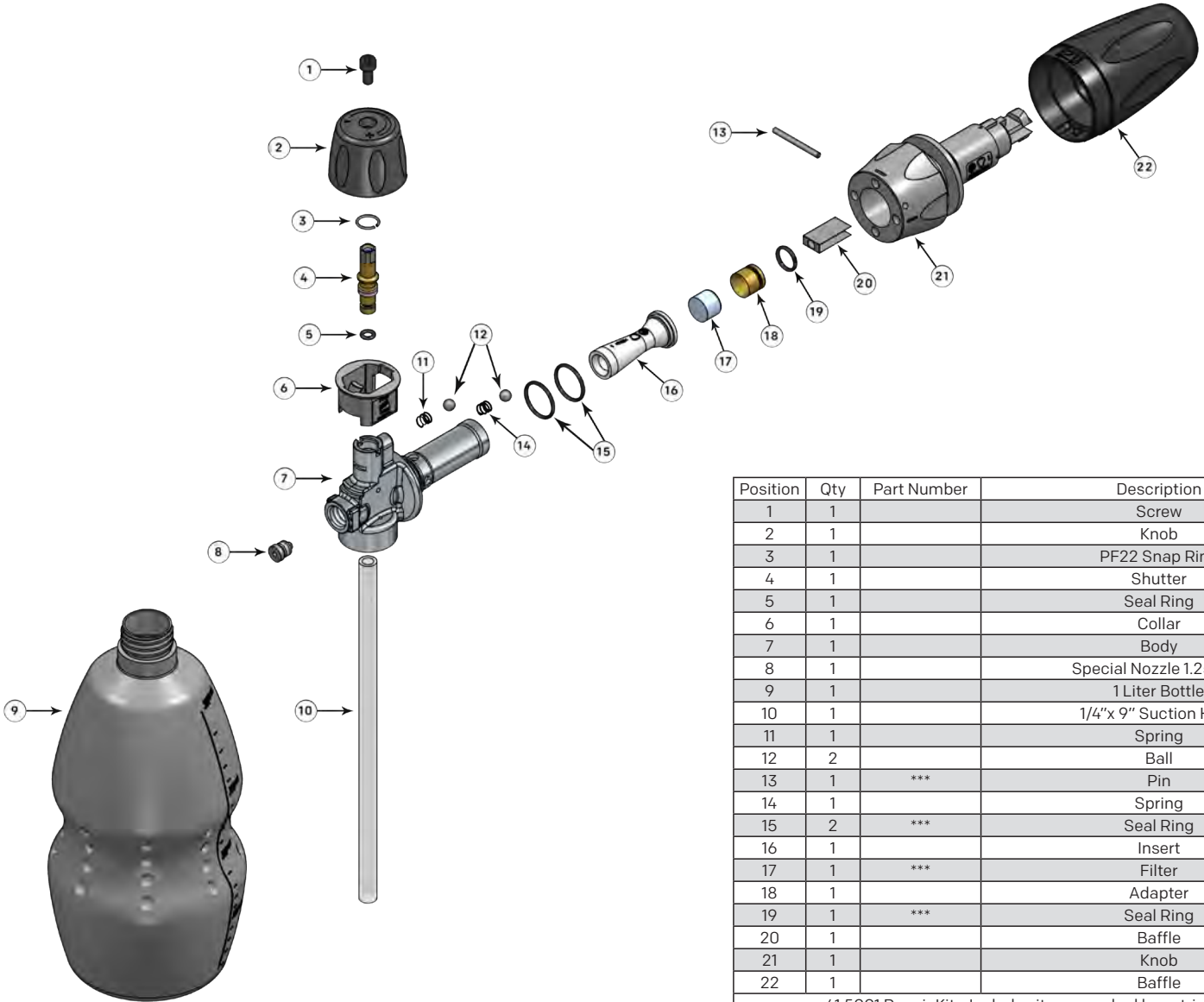

Position	Qty	Part Number	Description
1	1		Screw
2	1		Knob
3	1		PF22 Snap Ring
4	1		Shutter
5	1		Seal Ring
6	1		Collar
7	1		Body
8	1		Special Nozzle 1.25 mm
9	1		1 Liter Bottle
10	1		1/4" x 9" Suction Hose
11	1		Spring
12	2		Ball
13	1	***	Pin
14	1		Spring
15	2	***	Seal Ring
16	1		Insert
17	1	***	Filter
18	1		Adapter
19	1	***	Seal Ring
20	1		Baffle
21	1		Knob
22	1		Baffle
41.5001 Repair Kit - Includes items marked by astrisks ***			



Left For Less Chemical Draw
Right For More Chemical Draw



Left For Wider Spray Pattern
Right For Narrower Spray Pattern

14.5001 PF22 Professional Foam Lance					
Part Number	Min-Max PSI	Min-Max GPM	Max Temp.	Inlet	Ø Nozzle (mm)
14.5001	1,100-5,000 PSI	1.8-5.3 GPM	140°	1/4"	1.25 mm
Replacement Parts					
37.0451	PF22 Replacement 1 Liter Bottle				
41.5001	PF22 Filter, Pin, O-Ring Repair Kit				