



Gas engine must be purchased separately.

## FEATURES

- Triplex plunger design provides a smooth liquid flow.
- Special concentric, high-density, polished, solid ceramic plungers provide a true wear surface and extended seal life.
- Built-in flange mount for easy, direct mounting to most gas engines. Eliminates the need for pulleys, belts, gearboxes.
- Integral Regulating Unloader with built-in by-pass is standard for safety and pressure setting.
- Stacked stainless steel valve design for long life and easy servicing.
- Fixed Chemical Injector is standard and mounts directly onto Unloader to provide cleaning flexibility.

### **⚠ CAUTIONS AND WARNINGS**

All High Pressure Systems require a primary pressure regulating device (i.e. regulator, unloader) and a secondary pressure relief device (i.e. pop-off valve, relief valve). Failure to install such relief devices could result in personal injury or damage to pump or property. CAT PUMPS does not assume any liability or responsibility for the operation of a customer's high pressure system.

Read all CAUTIONS and WARNINGS before commencing service or operation of any high pressure system. The CAUTIONS and WARNINGS are included in each service manual and with each Accessory Data sheet. CAUTIONS and WARNINGS can also be viewed online at [www.catpumps.com/cautions-warnings](http://www.catpumps.com/cautions-warnings) or can be requested directly from CAT PUMPS.

### **WARRANTY**

View the Limited Warranty on-line at [www.catpumps.com/warranty](http://www.catpumps.com/warranty).

## Direct-Drive Plunger Pump

**Model 67PPX39G11**

### SPECIFICATIONS

	U.S. Measure	Metric Measure
Flow .....	3.9 gpm	(14.8 lpm)
Pressure Range.....	100 to 4200 psi	(7 to 290 bar)
RPM .....	3450 rpm	(3450 rpm)
Inlet Pressure Range.....	Flooded to 75 psi	(Flooded to 5 bar)
Bore .....	0.551 "	(14 mm)
Stroke.....	0.405 "	(10.3 mm)
Crankcase Capacity.....	13.5 oz.	(0.4 l)
Maximum Liquid Temperature .....	140°F	(60°C)
Above 130°F call Cat Pumps for inlet conditions and elastomer recommendations.		
Inlet Port (1).....	1/2" NPTF	(1/2" NPTF)
Discharge Port (1).....	3/8" NPTF	(3/8" NPTF)
Discharge Port w/Chemical Injector (1) .....	3/8" NPTM	(3/8" NPTM)
Inlet Auxiliary Port (1) .....	1/4" NPTF	(1/4" NPTF)
Shaft Diameter (Hollow) .....	1"	(25.4 mm)
Weight.....	17 lbs.	(7.7 kg)
Dimensions.....	11.50 x 8.82 x 7.99"	(292 x 224 x 203 mm)
Mounting Flange: SAE J609, Flange B, Extension 4 (1"Ø), Shaft Length = 3 1/4", Pilot Ø = 5 3/4", B.C. Ø = 6 1/2", Thread = 3/8"-16 UNC TAP		

### ELECTRIC HORSEPOWER REQUIREMENTS

MODEL	FLOW		PRESSURE			RPM
	U.S. gpm	lpm	psi 2500	psi 3200	psi 4200	
<b>67PPX39G11</b>	3.9	14.8	6.7	8.5	11.2	3450

<b>DETERMINING THE PUMP R.P.M.</b>	Rated gpm	=	"Desired" gpm
	Rated RPM	=	"Desired" RPM
<b>DETERMINING THE REQUIRED H.P.</b>	gpm x psi	=	Electric Brake
	1460	=	H. P. Required
<b>DETERMINING MOTOR PULLEY SIZE</b>	Motor Pulley O.D.	=	Pump Pulley O.D.
	Pump RPM	=	Motor RPM

Note: Consult engine manufacturer when using gas or diesel engine. Refer to pump **Service Manual** for repair procedure and additional technical information.

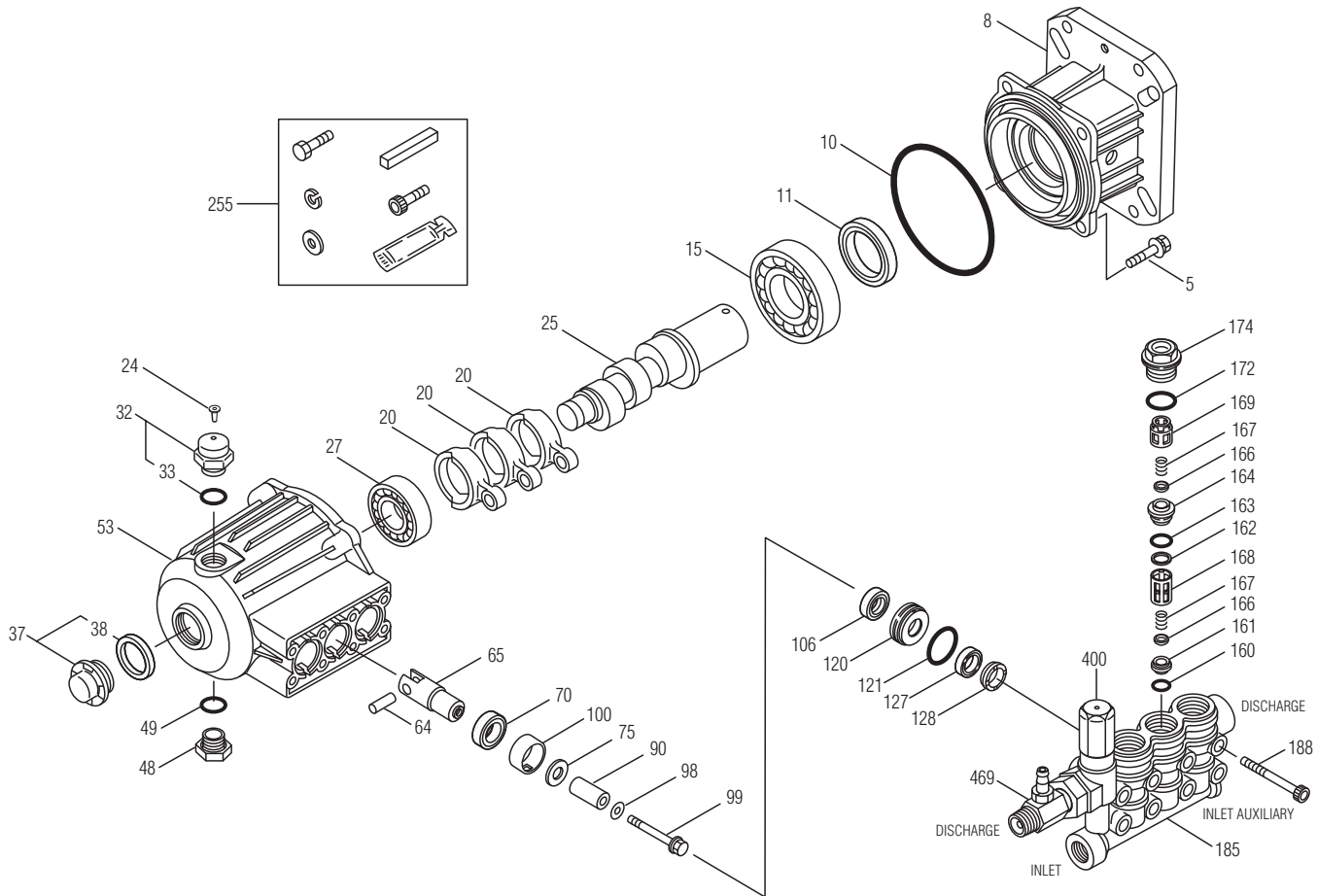

**PARTS LIST**

ITEM	P/N	MATL	DESCRIPTION	QTY	ITEM	P/N	MATL	DESCRIPTION	QTY
5	127285	STCP R	Screw, HH, Sems (M8x25)	4	106	45188	NBR	Seal, LPS w/S-Spg	3
8	49361	AL	Cover, Adapter Bearing	1	120	49374	BB	Case, Seal	3
10	14043	NBR	O-Ring, Bearing Cover	1	121	13977	NBR	O-Ring, Seal Case - 70D	3
11	125351	NBR	Seal, Oil Crankshaft	1	127	48758	SNG	V-Packing	3
15	146421	STL	Bearing, Ball - Inner	1	128	48757	NY	Adapter, Male	3
20	49364	TNM	Rod, Connecting	3	160	26129	NBR	O-Ring, Inlet Valve Seat - 70D	3
24	549608	LDPE	Plug, Oil Cap	1	161	49378	S	Seat, Inlet	3
25	49391	CM	Crankshaft (10.3mm)	1	162	48361	D	Back-up-Ring, Discharge Seat	3
27	49363	STL	Bearing, Ball - Outer	1	163	43358	NBR	O-Ring, Discharge Seat - 70D	3
32	547961	RTP	Cap, Oil Filler w/O-Ring	1	164	49376	S	Seat, Discharge	3
33	14179	NBR	O-Ring, Filler Cap - 70D	1	166	547098	S	Valve	6
37	92241	—	Gauge, Oil Bubble w/Gasket - 80D	1	167	49354	S	Spring	6
38	44428	NBR	Gasket, Flat, Oil Gauge - 80D	1	168	49377	PVDF	Retainer, Spring, Inlet	3
48	44842	NY	Plug, Drain	1	169	547441	PVDF	Retainer, Spring, Discharge	3
49	14179	NBR	O-Ring, Drain Plug - 70D	1	172	49382	NBR	O-Ring, Valve Plug - 90D	3
53	49352	AL	Crankcase	1	174	49380	BB	Plug, Valve	3
64	49366	CM	Pin, Crosshead	3	185	49372	BB	Head, Manifold	1
65	49368	BB	Rod, Plunger	3	188	126512	STCP R	Screw, HSH (M8x65)	8
70	47215	NBR	Seal, Oil Crankcase - 70D	3	255	31445	STZP	Assy, Bolt Mount, Gas	1
75	49370	S	Slinger, Barrier	3	300	76118	NBR	Kit, Seal (Incls: 106 and 127)	1
90	49367	CC	Plunger (M14x28)	3	310	76156	NBR	Kit, Valve Pre-Assembled	1
98	46730	NBR	Washer, Seal - 90D	3				(Incls: 160,161,162,163,164,166,167,168,169,172)	
99	49369	S	Retainer, Plunger	3	400	—	—	Unloader, Integral (See individual parts)	1
100	49371	NY	Retainer, Seal	3	469	7367	BB	Injector, Chemical Fixed	1

*Italics are optional items.* R Components comply with RoHS Directive.

MATERIAL CODES (Not Part of Part Number): AL=Aluminum BB=Brass CC=Ceramic CM=Chrome-moly D=Acetal LDPE=Low Density Polyethylene  
 NBR=Medium Nitrile (Buna-N) NY=Nylon PVDF=Polyvinylidene Fluoride RTP=Reinforced Composite S=304SS SNG=Special Blend (Buna)  
 STCP=Steel/Chrome Plated STL=Steel STZP=Steel/Zinc Plated TNM=Special High Strength

# INTEGRAL UNLOADER

## SPECIFICATIONS

Flow .....	3.9 gpm	<b>U.S. Measure</b>	<b>Metric Measure</b>
PSI Range .....	100-4200 psi		(14.8 lpm)
Inlet Port .....	1/2" NPTF		(7-290 bar)
Discharge Port With Chemical Injector .....	3/8"NPTM		(1/2" NPTF)
			(3/8"NPTM)

# UNLOADER TYPE

An integral unloader with built-in by-pass is part of the discharge manifold to provide system pressure regulation and pump protection. This pump also includes a fixed chemical injector for chemical application.

## OPERATION:

Pump should be purged of air before commencing with operation. Liquid must flow through the pump without discharge restriction to assure full system pressure is reached.

Install a pressure gauge close to the manifold head of the pump to assist in setting system pressure and to periodically monitor system pressure.

Setting and adjusting the unloader pressure must be done with the system turned on. Start the system with the unloader backed off to the lowest pressure setting (counterclockwise direction). Squeeze the trigger and read the pressure on the gauge at the pump. Do not read pressure at the gun or nozzle. If more pressure is desired, release the trigger, turn adjusting cap one quarter turn in a clockwise direction. Squeeze the trigger and read the pressure. Repeat this process until the desired system pressure is reached. Thread locking nut up to adjusting cap and tighten set screw. All high pressure systems should have a secondary relief valve. Set secondary relief valve 200-300 psi above the unloader setting.

**NOTE:** Pressure is not set at the factory.

## SERVICE:

The unloader should be serviced on the same schedule as the seals in the pump. Refer to Service Manual for start-up, servicing of seals and valves, torque requirements and Diagnosis/Maintenance chart.

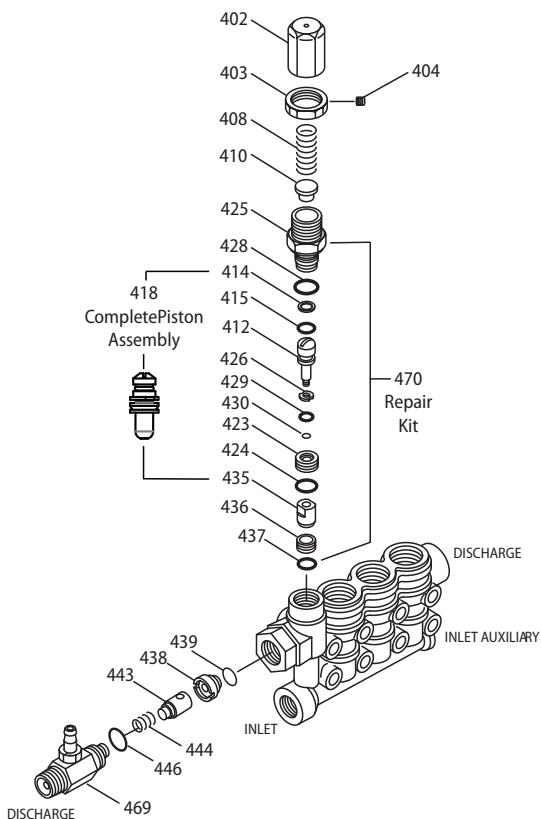

## PARTS LIST

ITEM	P/N	MATL	DESCRIPTION	QTY
402	49099	BB	Cap, Adjusting	1
403	125521	BB	Nut, Locking (M25x1)	1
404	88953	S	Screw, Set (M4x4)	1
408	45198	ZP R	Spring, Pressure	1
410	49101	STZP	Retainer, Spring	1
412	49103	S	Stem, Piston	1
414	129638	PTFE	Back-up-Ring, Piston Stem	1
415	49104	NBR	O-Ring, Piston Stem - 90D	1
418	—	BB	Assy, Piston (Included in Repair Kit)	1
423	49105	BB	Retainer, Valve	1
424	49106	NBR	O-Ring, Valve Retainer - 70D	1
425	49102	BB	Retainer, Piston	1
426	49107	S	Washer	1
428	26133	NBR	O-Ring, Piston Retainer - 80D	1
429	22056	NBR	O-Ring, Valve Retainer - 70D	1
430	49123	D	Back-up-Ring, Valve Retainer	1
435	49383	S	Valve/Ball Assembly	1
436	49384	S	Seat	1
437	13965	NBR	O-Ring, Seat - 70D	1
438	49386	D	Seat, Check Valve	1
439	13963	NBR	O-Ring, Check Valve Seat - 70D	1
443	49245	BB	Valve, Check w/NBR O-Ring	1
444	117275	S	Spring, Check Valve	1
446	26133	NBR	O-Ring, Body - 80D	1
468	76708	NBR	Kit, O-Ring (Incls: 414, 415, 424, 428, 429, 430, 437, 439, 446)	1
469	7367	BB	Injector, Chemical Fixed	1
470	31556	NBR	Kit, Repair (Incls: 412, 414, 415, 423-426, 428-430, 435-437)	1

*Italics are optional items.* R Components comply with RoHS Directive.

MATERIAL CODES (Not Part of Part Number): BB=Brass D=Acetal  
NBR=Medium Nitrile (Buna-N) NY=Nylon PTFE=Pure Polytetrafluoroethylene  
S=304SS STZP=Steel/Zinc Plated ZP=Zinc Plated

## FIXED CHEMICAL INJECTOR

### SPECIFICATIONS

	<b>U.S. Measure</b>	<b>Metric Measure</b>
Model 7367		
GPM .....	3.9 gpm	(14.8 lpm)
Nozzle Orifice .....	2.1 mm	(2.1 mm)
Hose Barb .....	1/4"	(1/4")
Tapped Barb .....	8/32" UNF	(8/32" UNF)
Inlet Port .....	M20x1.0	(M20x1.0)
Discharge Port .....	3/8" NPTM	(3/8" NPTM)
Weight .....	5.3 oz.	(0.15 kg)
Dimensions .....	2 x 1 x 1.75"	(51 x 25 x 45 mm)

### CHEMICAL INJECTOR PERFORMANCE CHART

Orifice Size	Injector Model	Maximum Injecting Pressure	Maximum Chemical Draw	Pressure Drop Across Injector At System Pressure (4000 psi)
2.1 mm	7367	358 psi	76.8 oz/min	288 psi

Optimum performance of chemical injector occurs with a 35 ft. high pressure hose and a minimum 3/8" I.D. The type of hose, extended lengths, reduced I.D. and fittings may create back pressures in excess of the low pressure nozzle rating and prevent the injector from drawing chemical.

**CAUTION:** Deduct the pressure drop shown in the performance chart from your desired system pressure to arrive at the maximum high pressure nozzle rating. This is essential to avoid over-pressurizing the pump.

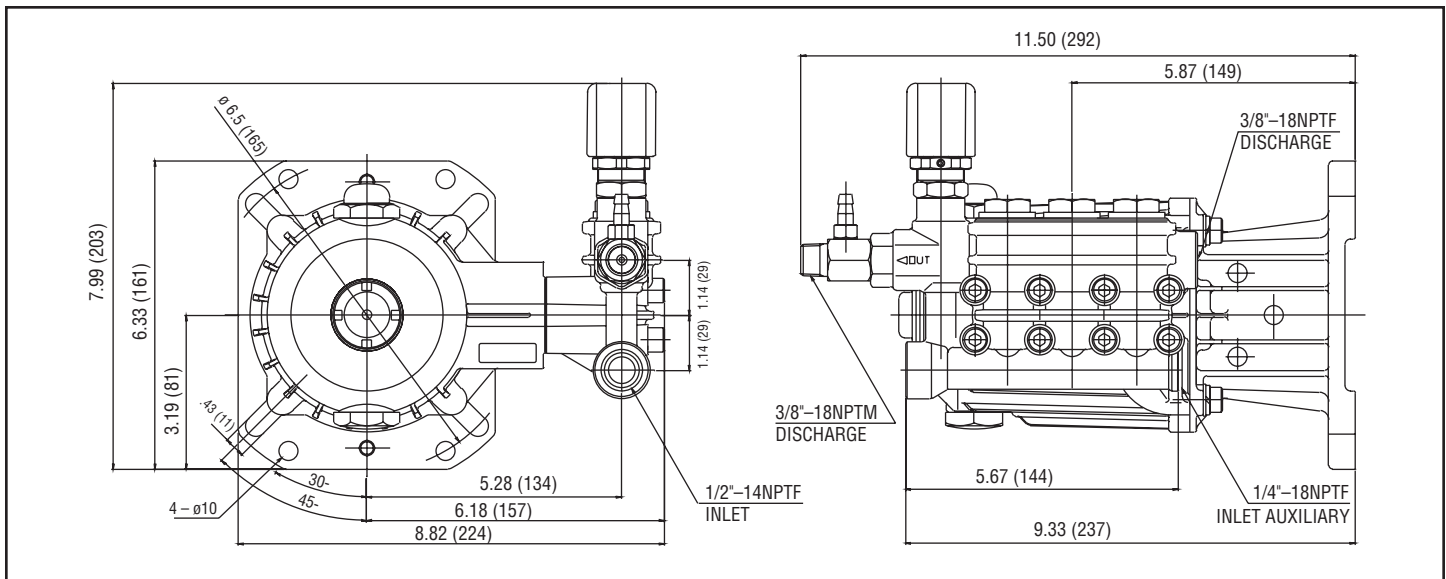

Model 67PPX39G11

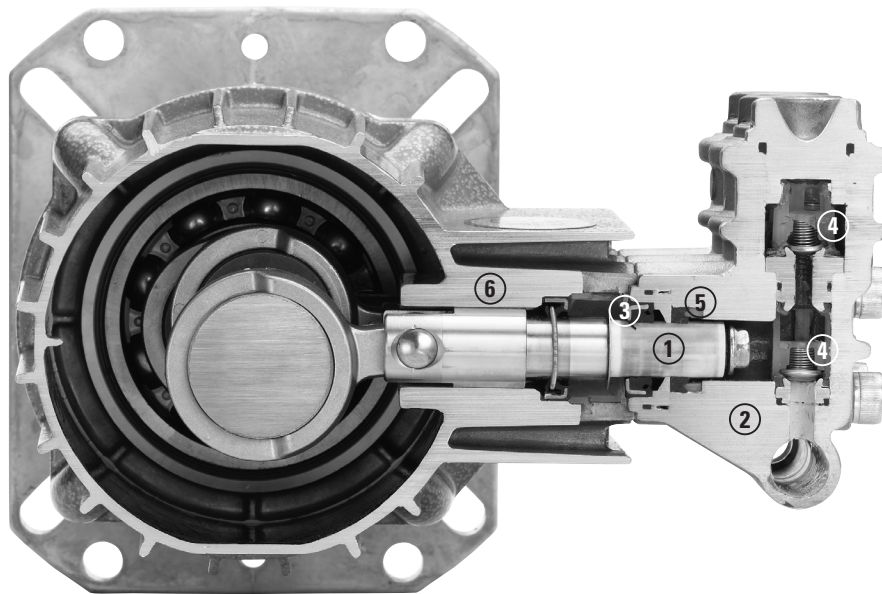

- 1 Special concentric, high-density, polished, solid ceramic **plungers** provide a true wear surface and extended seal life.
- 2 High tensile strength, forged brass **manifold** head with built-in integral unloader and eight mounting screws for exceptional strength.
- 3 100% wet **seal** design adds to service life by allowing pumped liquids to cool and lubricate on both sides.
- 4 Stacked **valve assemblies** include stainless steel valves, seats and springs to provide corrosion-resistance, ultimate seating and extended life.
- 5 Unique design and specially formulated **V-Packings** offer unmatched performance and seal life.
- 6 **Crossheads** are 360° supported for uncompromising alignment.



**CAT PUMPS**  
 1681 - 94TH LANE N.E. MINNEAPOLIS, MN 55449-4324  
 PHONE (763) 780-5440 — FAX (763) 780-2958  
 e-mail: techsupport@catpumps.com  
 www.catpumps.com