



Electric Pressure Washer

Model No. CPU0204

NOTE: REFER TO PRODUCT MANUAL FOR ALL SAFETY INSTRUCTIONS

Operations & Parts Manual

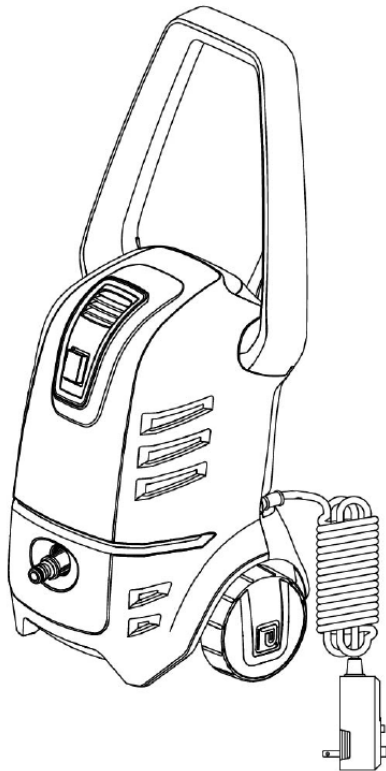

Table Of Contents

- Technical Data
- Important Safety Tips, Precautions, Warnings and Usage Instructions
- Assembly Instructions
- Operating Instructions
- Detergents
- Clean-up and Storage
- Cleaning Tips
- Troubleshooting Tips
- Explosive Drawing
- Parts Manual

Technical Data

Mains voltage:.....	120 V
Mains frequency:.....	60 Hz
Max. operating pressure:.....	1400PSI
Water consumption:.....	1.4 GPM
Max. pressure water supply:.....	0.3 Mpa
Max. water temperature:.....	5-60°C
Weight:.....	9 Kg

Important Safety Tips

Never point the high-pressure nozzle at people or animals.

Never drink alcohol or use drugs while operating the pressure washer.

Never operate the pressure washer while standing in water.

Never touch the electrical plug with wet hands.

Never let electrical connections rest in water.

Never operate pressure washer without the water turned on.

Never use hot water with this pressure washer.

GROUND FAULT CIRCUIT INTERRUPTER (GFCI)

This pressure washer is provided with a ground fault circuit interrupter (GFCI) built into the plug of the power supply cord. This device provides additional protection from the risk of electric shock. Should replacement of the plug or cord become necessary, use only identical replacement parts that include GFCI protection.

This unit is equipped with a Ground Fault Circuit Interrupter (GFCI). When connecting the GFCI to the receptacle, the indicator should appear red. If the indicator is not red, depress the RESET button on the GFCI until the indicator appears red. If the indicator does not appear red, please see Section titled "Troubleshooting" for more information.

IMPORTANT SAFETY PRECAUTIONS

WARNING: When using this product, basic precautions should always be followed, including the following:

1. Read all instructions before using the product. Save all safety instructions.
2. Do not operate the pressure washer when fatigued or under the influence of alcohol or drugs.
3. Risk of injection or injury - do not direct the high pressure water stream at any people or animals.
4. Do not allow children to operate the pressure washer at any time.

5. To reduce the risk of injury, close supervision is necessary when the pressure washer is used near children.
6. Know how to stop the unit and reduce pressure immediately. Be completely familiar with the controls.
7. Stay alert - always be aware of where you are directing the high pressure spray
8. Keep cleaning area clear of all people.
9. Keep good footing and balance at all times - do not overreach or stand on an unstable support.
10. The work area should have adequate drainage to reduce the possibility of a fall due to slippery surfaces.
11. Follow the maintenance instructions specified in the manual.
12. To reduce the risk of electrocution, keep all connections dry and off the ground. Do not touch plug with wet hands.

GENERAL SAFETY PRECAUTIONS

1. Intended for outdoor household use only.
2. High-pressure hose can develop leaks from wear, abuse, kinking etc. Do not use a damaged hose.
3. Do not use the pressure washer in areas near combustible materials, combustible fumes, or dust.
4. Some chemicals or detergents may be harmful if inhaled or ingested causing severe injury. Use a respirator or mask whenever there is a chance that vapors may be inhaled. Read all instructions included with the mask so you are certain the mask will provide the necessary protection against inhaling harmful vapors.
5. Before starting the pressure washer in cold weather, check all of the parts of the equipment and be sure that ice has not formed. Do not store the unit anywhere that the temperature will fall below 0°C (32°F).
6. **DO NOT MAKE ANY MODIFICATIONS TO ANY OF THE COMPONENTS!** Units with broken or missing parts, or without the protective housing or covers should **NEVER** be operated
7. Keep the high-pressure hose connected to the pressure washer and the spray gun while the system is pressurized. Disconnecting the hose while the unit is pressurized is dangerous, and may cause injury.
8. Do not leave the pressure washer unattended while the power switch is ON.
9. Keep water spray away from electrical wiring or fatal electric shock may result.

SERVICING OF A DOUBLE-INSULATED APPLIANCE

In a double-insulated product, two systems of insulation are provided instead of grounding. No means of grounding is provided on a double-insulated product, nor should a means for grounding be added to the product. Servicing a double-insulated product requires extreme care and knowledge of the system, and should be done only by qualified service personnel. Replacement parts for a double-insulated product must be identical to the parts they replace. A double-insulated product is marked with the words "DOUBLE INSULATION" or "DOUBLE INSULATED". This symbol may also  be marked on the product.

USE OF EXTENSION CORDS

Use of an extension cord with this product is **NOT RECOMMENDED**. If you must use an extension cord, use only extension cords that are intended for outdoor use. These cords are identified by a marking "ACCEPTABLE FOR USE WITH OUTDOOR APPLIANCES, STORE INDOORS WHILE NOT IN USE." Use only extension cords having an electrical rating not less than the rating of the product. Examine extension cord before use. Do not use damaged extension cords! Do not pull on cord to disconnect from receptacle, always disconnect by pulling on plug. Keep cord away from heat and sharp edges. Always disconnect the extension cord from the receptacle before disconnecting the product from the extension cord.

WARNING - To reduce the risk of electrocution, keep all connections dry and off the ground. Do not touch the plug with wet hands.

PROPER USE OF THE PRESSURE WASHER

THIS UNIT IS INTENDED FOR USE WITH COLD WATER ONLY!
DO NOT USE HOT WATER IN THIS PRESSURE WASHER.

1. Operate the pressure washer at no more than the fluid pressure rated for the pressure washer. Never run the pressure washer without a water supply. Running the unit without a water supply will cause irreparable damage to the unit.
2. Make sure that the water supply you use for the pressure washer is not dirty, sandy, and does not hold any corrosive chemical products. Using a dirty water supply will compromise the long life of the pressure washer.
3. **CAUTION** - The pressure washer can be used for a variety of applications including washing cars, boats, patios, decks, garages etc. where high pressure is necessary to remove dirt and debris. High-pressure water flow can damage the work surface if not used properly! See the section titled "Operating Instructions" for more details. Always test the spray in an open area first.
4. **NEVER** move the unit by pulling on the high pressure hose. Use the handle provided on the top of the unit.

- 5. Always hold the high pressure gun and wand with two hands. Keep one hand on the gun/trigger, while supporting the wand with the other hand (see diagram).
- 6. When dispensing detergent, the pressure washer applies detergent to the cleaning area at low pressure only. Once the detergent has been applied, spray the detergent off of the work area by using the adjustable nozzle.

ASSEMBLY INSTRUCTIONS

Unpacking the Carton

After opening the carton, please remove all parts and check them against the following list of components that are included:

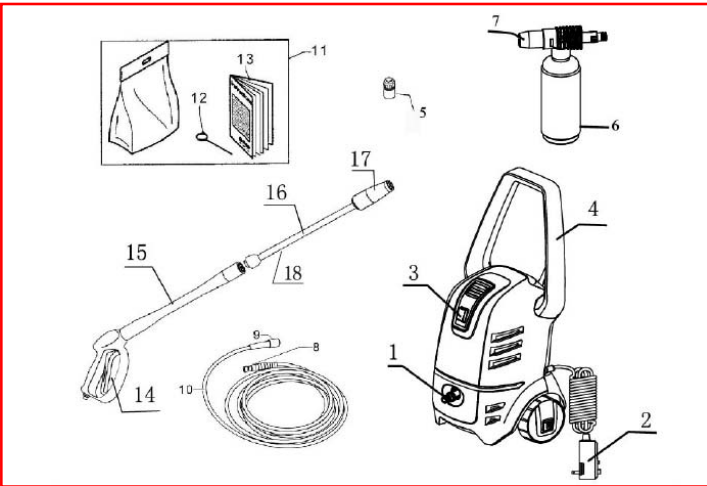

Fig. 1

- 1) Inlet connector
- 2) Power plug with GFCI
- 3) Main switch
- 4) Handle
- 5) Quick connector
- 6) Detergent bottle
- 7) Bottle Nozzle
- 8) Hose connector with appliance
- 9) Hose connector with spray gun
- 10) High pressure washer hose
- 11) Packing of fittings
- 12) Tip cleaner
- 13) Instruction manual
- 14) Trigger safety lock
- 15) Pistol grip
- 16) Spray lance
- 17) Turbo lance
- 18) XXX

图片和编号不匹配，修改

To assemble the enclosed parts, please refer to the steps that follow:

Step 1

Attach the high pressure hose to the gun. Use a wrench to tighten the fitting.

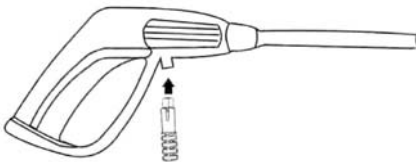

Step 2

Connect the adjustable lance to the gun.

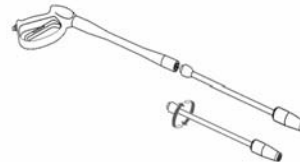

Step 3

Attach the high-pressure hose to the male fitting on the back of the pressure washer.



Step 4

Attach the garden hose to the brass connector which on the front of pressure washer. Connect the garden hose to the waterspout.



OPERATING INSTRUCTIONS

THIS UNIT IS INTENDED TO BE USED WITH COLD WATER ONLY!
DO NOT USE HOT WATER IN THIS PRESSURE WASHER!

Starting Up

After connecting the pressure washer to your cold water supply, proceed as follows:

- Make sure that the on/off switch is in the off position.
 - Connect the garden hose to the inlet fitting.
 - Attach the hose to the gun as per assembly instruction step #1.
 - Insert the adjustable spray nozzle into the gun as per assembly step #2.
 - Connect the high pressure hose to the high pressure outlet fitting as per assembly step #3.
 - Open the water supply valve completely.
 - Before turning the unit on, press the gun trigger to bleed all the remaining air out of the pump and hose.
 - Start the pressure washer by turning the on/off switch to the on position and squeeze the trigger.
- REMINDER: Motor does not run continuously, only when the trigger is squeezed.

WARNING - RISK OF INJECTION! Unit will start spraying when trigger is squeezed. When turning the unit off after use, high pressure still exists inside the hose and unit. Point the gun in a safe direction and discharge the excess pressure. NEVER direct the high pressure water stream at people or animals.

Automatic On / Off

The pressure washer is equipped with an automatic on/off switch. The pressure washer will only run when the power switch is in the ON position and the trigger on the gun is squeezed. When you release the trigger to stop spraying water through the gun, the motor on the pressure washer will automatically shut off. Simply squeeze the trigger again to resume using the washer. To stop using the pressure washer, release the trigger and switch the unit to the OFF position. The unit should be turned completely OFF while not in use or while unattended.

Bleeding The Gun

It is very important to bleed all the air out of the pressure washer before using it. To do this

- 1 . Release trigger lock.
2. Squeeze the trigger before turning the electrical supply on.This removes any air trapped inside the pressure washer and lance before using the units.
3. Continue holding trigger for approximately one minute to allow any excess air out of the unit. Water will flow through the gun at low pressure during this procedure.
4. Lock the trigger.
5. Plug the mains power cable into the electricity supply.
6. Release the trigger lock.
7. Turn the on/off switch clockwise to the I/ON position.

The pressure washer is ready to using now.

Gun Safety Lock

This pressure washer is equipped with a gun trigger safety lock. When not using the pressure washer, use the safety lock to keep from accidentally engaging the high pressure spray.

Adjustable Spray Nozzle

The adjustable nozzle will allow you to use any variety of spray patterns from a full fan spray (Diagram 1) to a direct stream spray (Diagram 2). When using the pressure washer to clean wood decks, siding, vehicles etc., always start using the fan spray and begin spraying from a minimum 36" away to avoid damaging the surface of the material you are cleaning. Always begin by spraying in a testing area free and clear of people and objects.

Adjustable Spray Nozzle

The adjustable nozzle will allow you to use any variety of spray patterns from a full fan spray (Diagram 1) to a direct stream spray (Diagram 2). When using the pressure washer to clean wood decks, siding, vehicles etc., always start using the fan spray and begin spraying from a minimum 36" away to avoid damaging the surface of the material you are cleaning. Always begin by spraying in a testing area free and clear of people and objects.

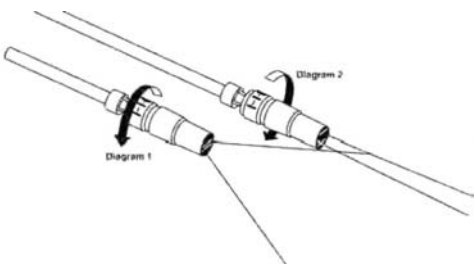

ADJUSTING THE SPRAY PATTERNS

To adjust the spray patterns proceed as follows:

1. Hold the shaft of the lance in one hand.
2. Turn the nozzle clockwise to obtain FAN spray pattern.
3. Turn the nozzle anticlockwise to obtain STREAM spray pattern.
4. Slide the nozzle out to LOW-PRESSURE position to obtain DETERGENT dispense.

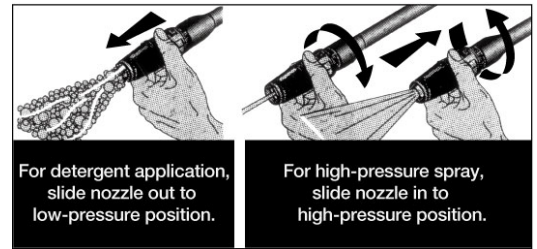

TOTAL STOP SYSTEM

The pressure washer is fitted with a total stop system to protect the motor when in use.

When the trigger is released the motor will stop.

When the trigger is squeezed the motor will start up again.

USING DETERGENTS

The pressure washer will dispense detergent only at low pressure.

Use the adjustable spray nozzle to apply detergents and to rinse clean.

Biodegradable detergents are specifically formulated to protect the environment and your pressure washer. These Detergents will not clog the filter and will protect the internal parts of the pressure washer for a longer life.

Step 1

Take out the bottle from the holder and open the cap of bottle.



Step 2

Fill the detergent reservoir with any approved liquid detergent. Close the cover.

Step 3

Insert the Nozzle into the connector, push and turn the nozzle clockwise onto the connector until hand tight to lock it in place.



Step 4

Attach the connector to the spray gun handle

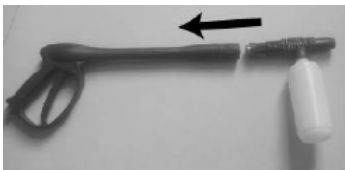

Step 5

To apply the detergent cleanser to your working area, turn the pressure washer switch to the ON position. Pull the trigger to operate the unit. The pressure washer will mix the detergent with water. Do not allow the detergent to dry on the object that you are cleaning.

WARNING: NEVER USE PRODUCTS WITH BLEACH OR CHLORINE OR ANY OTHER CORROSIVE MATERIALS, INCLUDING LIQUIDS CONTAINING SOLVENTS (I.E. GAS, OILS ETC), TRI-SODIUM PHOSPHATE PRODUCTS, AMMONIA, OR ACID-BASED CLEANERS. THESE CHEMICALS WILL HARM THE UNIT AND CAUSE DAMAGE TO THE SURFACE BEING CLEANED. ALWAYS READ THE LABEL.

Step 6

To clean the working area, turn the nozzle to STREAM position to obtain high pressure mode. Spray high-pressure water onto working area to rinse off the work area and any remaining detergent.



CLEAN-UP AND STORAGE

Shutting Down the Pressure Washer

WHEN FINISHED USING THE PRESSURE WASHER, FOLLOW THESE STEPS TO SHUT DOWN THE UNIT:

- Turn the pressure washer to the OFF position.
- Turn off the water supply.
- Before disconnecting high-pressure hose connection, point the gun in a safe direction and discharge the high-pressure water.
- Disconnect high-pressure hose from the pressure washer and gun.
- Disconnect garden hose from the pressure washer.
- Remove excess water from the pump by tipping the unit on both sides to drain any remaining water from inlet and outlet fittings.
- Remove Water Intake Filter and flush with water to remove dirt or debris. Return filter once cleaned.
- Drain detergent reservoir and flush with running water.
- Wipe away any remaining water on all parts and fittings.
- Engage the gun safety lock.
- Store the pressure washer, parts, and accessories in an area with a temperature above 0°C (32°F).

Winterizing and Long-Term Storage

FOLLOW ALL OF THE ABOVE SHUT-DOWN PROCEDURES, ADDING THE FOLLOWING STEPS....

- After disconnecting the water supply, and before disconnecting the high-pressure hose, turn the pressure washer on for 2-3 seconds, until any remaining water in the pump exits. Turn unit off immediately.

CONTINUED USE OF THE PRESSURE WASHER WITHOUT WATER SUPPLY ATTACHED WILL CAUSE SEVERE DAMAGE TO THE UNIT!

- Always store the pressure washer, parts, and accessories in an area with a temperature above 0°C (32°F).

WARNING: FAILURE TO COMPLY WITH THESE STORAGE INSTRUCTIONS WILL RESULT IN DAMAGE TO THE PUMP ASSEMBLY.

Maintenance

- This pressure washer is supplied with a closed lubrication system, so no addition of oil is needed.
- Check all hoses and accessories for damage prior to use.
- Check the water intake filter periodically for deposits. Clean this filter regularly for maximum performance.



CLEANING TIPS

WARNING: ALWAYS TEST THE SPRAY IN AN AREA FREE AND CLEAR OF PEOPLE AND OBJECTS BEFORE YOU SPRAY AT THE INTENDED CLEANING SURFACE.

Wood and Vinyl Decks

Rinse deck and surrounding area with fresh water. If using detergent, fill the detergent reservoir and apply to the area being cleaned at low pressure. For optimal results, reduce your work area to smaller sections and clean each section one at a time. Allow the detergent to rest on the surface for a few minutes and then rinse at high pressure.

Do not let the cleanser dry. Always clean from left to right and top to bottom for best results. Rinse at high pressure using the fan spray keeping the tip of the spray nozzle at least 6-9 inches from the cleaning surface. Maintain a further distance from the cleaning area when using a direct spray.

Caution: For softer woods, increase the distance from the cleaning area.

Cement Patios, Stone, and Brick

Rinse cleaning and surrounding area with fresh water. If using detergent, fill the detergent reservoir and apply to the area being cleaned at low pressure. Rinse at high pressure using the fan spray in a sweeping motion keeping the tip of the spray nozzle at least 3-6 inches from the cleaning surface. Maintain a further distance from the cleaning area when using a direct spray.

Cars, Boats, and Motorcycles

Rinse cleaning and surrounding area with fresh water. If using detergent, fill the detergent reservoir and apply to the area being cleaned at low pressure. To achieve the best results, clean one side at a time. Allow the detergent to rest on the surface for a few minutes, but do not let the detergent dry. Rinse at high pressure using the fan spray in a sweeping motion keeping the tip of the spray nozzle at least 8 inches from the cleaning surface. Maintain a further distance from the cleaning area when using a direct spray. Wipe surface dry for a polished finish.

Barbecue Grills, Power Equipment, and Garden Tools

Rinse cleaning and surrounding area with fresh water. If using detergent, fill the detergent reservoir and apply to the area being cleaned at low pressure. Allow the detergent to rest on the surface for a few minutes, but do not let the detergent dry. Rinse at high pressure using the fan spray keeping the tip of the spray nozzle at least 1-3 inches from the cleaning surface. Maintain a further distance from the cleaning area when using a direct spray.

GUARANTEE

Refer to the enclosed guarantee conditions for the terms and conditions of guarantee.

ENVIRONMENT

Should your machine need replacement after extended use, do not put it in the domestic waste but dispose of it in an environmentally safe way.

TROUBLESHOOTING TIPS

WHEN THE SWITCH IS IN THE "ON" POSITION THE MACHINE WILL NOT START PROBABLE CAUSE	
PROBABLE CAUSE	SOLUTION
Electrical socket is faulty	Check plug, socket, and fuses
Voltage is inadequate	Check that the voltage is adequate
GFCI trips	Reset / Try another outlet
Power cord is not plugged in	Plug in power cord
THE PUMP DOES NOT REACH ADEQUATE PRESSURE OR FLUCTUATES	
PROBABLE CAUSE	SOLUTION
Water Intake Filter is clogged	Remove and clean filter
Pump is drawing air	Tighten connections/bleed system
Suction valves are clogged/worn	Clean or replace valves
Diameter of garden hose too small	Replace with 3/4 inch garden hose
Water supply is restricted	Check hose for kinks or leaks
Insufficient water supply	Fully open water source
THE PRESSURE WASHER HAS OR WILL NOT MAINTAIN PRESSURE	
PROBABLE CAUSE	SOLUTION
Excessive air in waterline and pump	Turn unit and water supply off / Bleed system / Hold trigger down
THE PRESSURE WASHER MAKES EXCESSIVE NOISE	
PROBABLE CAUSE	SOLUTION
Intake is blocked	Check the intake valves
Valves are worn, dirty, or clogged	Check, clean or replace valves
Water Intake Filter is dirty	Check, clean, or replace filter

THE MOTOR STOPS RUNNING WHILE IN USE	
PROBABLE CAUSE	SOLUTION
Net voltage lower than suggested	Check that the voltage is adequate

EXPLOSIVE DRAWING

- For replacement parts call 877-782-4111
- Please provide the following information: Model number, serial number (if any), parts description (as shown in parts list)
- Address all parts correspondence to: STC USA, 5365 Edith Lane, Roscoe, IL 61073

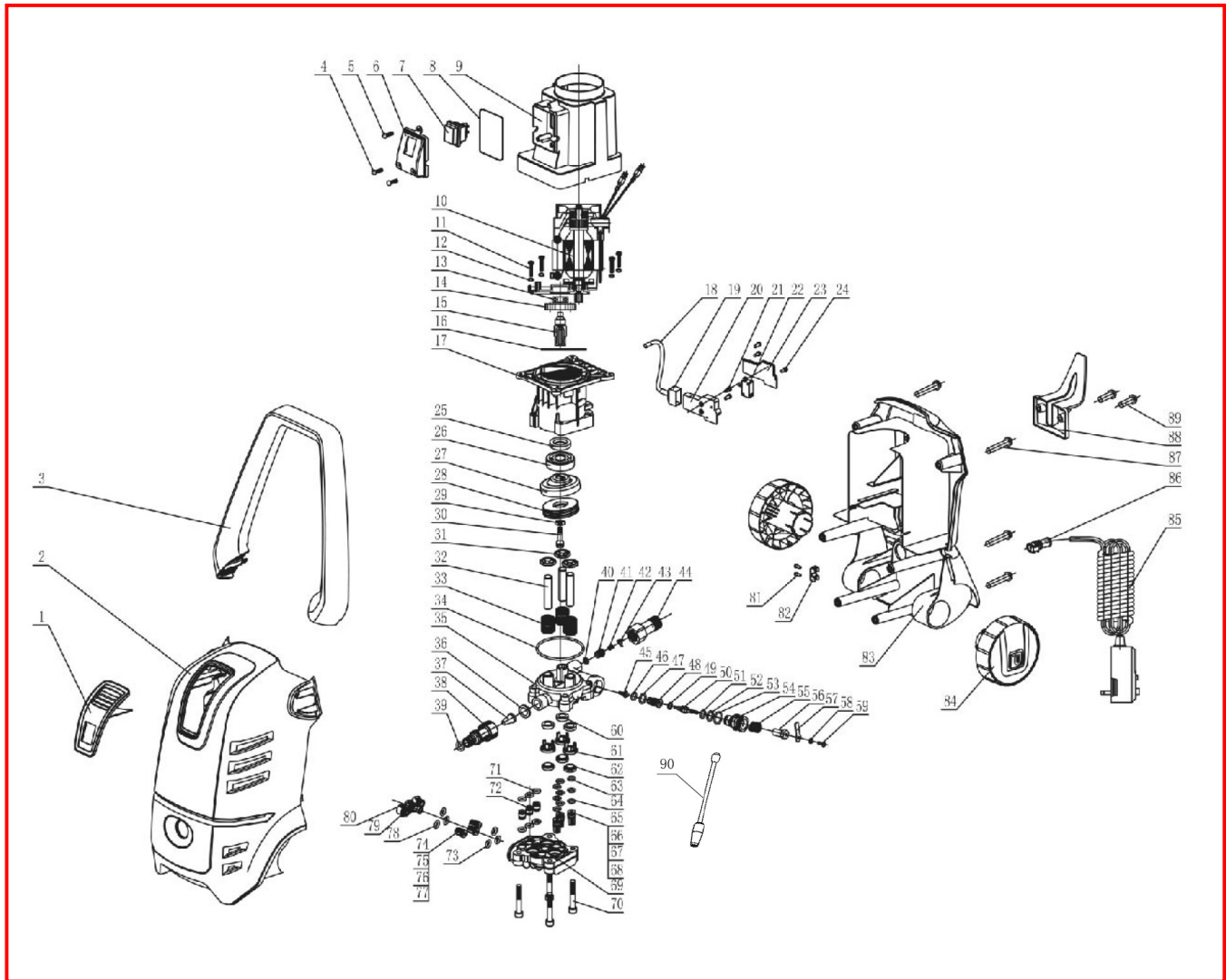

要确保以上爆炸图能清晰地印刷。编号要清晰！

Parts Manual

No.	Name	Qty	No.	Name	Qty	No.	Name	Qty
1	Switch cover	1	31	Plunger wedge	3	61	Tripod plunger Frame	3
2	Front panel	1	32	Plunger	3	62	Water seal	3
3	Handle	1	33	Piston spring	3	63	O-ring	6
4	Bolt	2	34	O-ring	1	64	O-ring	3
5	Bolt	1	35	Pump body	1	65	Inlet valve base	3
6	Junction box cover	1	36	Inlet screen	1	66	Inlet valve spring	3
7	Power switch	1	37	Washer	1	67	Inlet valve sheet	3
8	Seal	1	38	Inlet connector	1	68	Inlet Valve Frame	3
9	Motor housing	1	39	O-ring	1	69	Pump cover	1
10	Carbon brush motor	1	40	Bypass spring	1	70	Bolt	4
11	Bolt	4	41	Bypass blocker	1	71	O-ring	6
12	Washer	4	42	O-ring	1	72	Bridge Pipe	3
13	Bearing	1	43	Bypass clip	1	73	O-ring	3
14	Big gear	1	44	Outlet connector	1	74	Outlet valve base	3
15	Gear shaft	1	45	Bypass valve sheet	1	75	Outlet Valve Spring	3
16	O-ring	1	46	O-ring	1	76	Outlet valve sheet	3
17	Connection base	1	47	O-ring	1	77	Outlet valve Frame	3
18	Lead wire	1	48	valve frame	1	78	O-ring	3
19	Rubber Cover	1	49	O-ring	1	79	Short valve cap	2
20	Switch base	1	50	valve core	1	80	Long Valve cap	1
21	Bolt	2	51	O-ring	1	81	Wire fixing sheet	1
22	Micro-switch	1	52	O-ring	1	82	Bolt	2
23	Switch base cover	1	53	O-ring	1	83	Back shell	1
24	Bolt	3	54	valve base	1	84	Wheel	2
25	Frame oil seal	1	55	spring	1	85	Power cord	1
26	Bearing	1	56	Nut	1	86	Power cord cover	1
27	Eccentric Bowl	1	57	Switch board	1	87	Bolt	6
28	Thrust bearing	1	58	Washer	1	88	Hook	1
29	Bolt	1	59	Bolt	1	89	Bolt	2
30	Bolt	1	60	Oil seal	3			



Electric Pressure Washers

Limited Warranty

1. DURATION: From the date of purchase by the original purchaser - One Year
2. WHO GIVES THIS WARRANTY (WARRANTOR): ROCKFORD, Commercial Products, Roscoe, Illinois 61071, Telephone: 1- 877-782 - 4111
3. WHO RECEIVES THIS WARRANTY (PURCHASER): The original purchaser (other than for purposes of resale) of the Rockford pressure washer.
4. WHAT PRODUCTS ARE COVERED UNDER THIS WARRANTY: Any Rockford Pressure Washer supplied or manufactured by the Warrantor.
5. WHAT IS COVERED UNDER THIS WARRANTY: Substantial defects on material and workmanship which occur within the duration of the warranty period with the exceptions noted below.
6. WHAT IS NOT COVERED UNDER THIS WARRANTY:
 - A. Implied warranties, including those of merchantability and FITNESS FOR A PARTICULAR PURPOSE ARE LIMITED FROM THE DATE OF ORIGINAL PURCHASE AS STATED IN THE DURATION. If this pressure washer is used for commercial, industrial or rental purposes, the warranty will apply for ninety (90) days from the date of purchase.
 - B. ANY INCIDENTAL, INDIRECT, OR CONSEQUENTIAL LOSS, DAMAGE, OR EXPENSE THAT MAY RESULT FROM ANY DEFECT, FAILURE, OR MALFUNCTION OF THE CAMPBELL HAUSFELD PRESSURE WASHER. Some States do not allow the exclusion or limitation of incidental or consequential damages, so the above limitation or exclusion may not apply to you.
 - C. Any failure that results from shipping damage, accident, purchaser's abuse, neglect or failure to install and operate pressure washer in accordance with instructions provided in the owner's manual(s) supplied with product.
 - D. Pre-delivery service, i.e. assembly, oil or lubricants and adjustment.
 - E. Items or service normally required to maintain the pressure washer.
 - F. Additional items not covered under the warranty:
 1. Normal wear items such as high pressure hoses, water and oil seals, o-rings, valves, lances and spray tips.
 2. Motor brushes (Electric models only).
 3. Cosmetic defects that do not interfere with functionality.
 4. Rusted components.
 5. Pump wear or valve damage caused by using improper oil, oil contamination or by failure to follow proper oil maintenance guidelines.
7. RESPONSIBILITIES OF WARRANTOR UNDER THIS WARRANTY: Repair or replace. at Warrantor's option, pressure washer or component which is defective, has malfunctioned *and/or* failed to conform within duration of the warranty period.
8. RESPONSIBILITIES OF PURCHASER UNDER THIS WARRANTY:
 - A. Provide dated proof of purchase and maintenance records.
 - B. Deliver or ship the Rockford pressure washer or component to Rockford Commercial warehouse.Inc. Freight costs, if any, must be borne by the purchaser.
 - C. Use reasonable care in the operation and maintenance of the pressure washer as described in the owner's manual(s).
9. WHEN WARRANTOR WILL PERFORM REPAIR OR REPLACEMENT UNDER THIS WARRANTY: Repair or replacement will be scheduled and serviced according to the normal work flow at the servicing location, and depending on the availability of replacement parts.