



Operation, Breakdown, and Troubleshooting Manual

**24" Deublin Surface Spinner U-Handle
w/ Flat Free Tires ASE-0003U-FF**

**DO NOT USE OR OPERATE MACHINE UNTIL THIS MANUAL
HAS BEEN READ AND FULLY UNDERSTOOD**

TABLE OF CONTENTS

Introduction	1-1
Safety	2-1...2-2
Specifications	3-1
Set-Up and Operating Information	4-1...4-4
Routine Maintenance	5-1...5-2
Troubleshooting Guide	6-1...6-2
Deck Assembly Drawing and List	7-1...7-2
Warranty	8-1

(some pages intentionally left blank)

Introduction

To the Owner:

CONGRATULATIONS

You have just purchased the finest piece of cleaning equipment available, and it is made in America! With proper care and maintenance, it will provide long and dependable service.

This Manual contains safety suggestion and important instructions regarding this equipment. **Read this Manual thoroughly and retain for future reference.**

IMPORTANT NOTICE

If replacement parts are required, use only genuine original equipment parts. **DO NOT** use unauthorized parts or substitute materials.

Generic Symbols:

The following group of symbols are used in this manual to help communicate the intent of the instructions. When one of the symbols appears, it conveys the meaning defined below.



Safety Alert - Serious injury or damage can result if instructions are **not** followed.



Hourly Service Interval.



Unacceptable (NOT OK) Condition.



Caution - Chemicals are corrosive to operator and equipment.



Inspection Required.

Safety



THIS SAFETY ALERT SYMBOL INDICATES IMPORTANT MESSAGES IN THIS MANUAL. WHEN YOU SEE THIS SYMBOL, CAREFULLY READ THE MESSAGE THAT FOLLOWS AND BE ALERT TO THE POSSIBILITY OF PERSONAL INJURY OR DEATH.

IMPORTANT:

United States Government safety standards have been adopted under the Occupational Safety and Health Act. These standards, particularly the General Standards, Part 1910, and the Construction Standards, Part 1926 - should be consulted in connection with your use of airless spray equipment.

Safety Rules



We can not anticipate every possible circumstance that might involve potential hazard. The warnings, cautions and safety suggestions in this manual are therefore not all inclusive. If an operating procedure, installation, maintenance or work method not specifically recommended is used, you must satisfy yourself that it is safe for you and other persons. You must also ensure that the product will not be damaged or be made unsafe by the procedure that you choose.



Warning:

Fluids under high pressure spray can be nearly invisible and can penetrate the skin and cause extremely serious injury!

If any fluid appears to have penetrated the skin, get emergency medical care at once! Do not treat it as a simple cut. Tell your doctor exactly what fluid was injected. For treatment instructions, have your doctor call the:

**National Poison Control Network
(412) 681-6669**

- **Never** put hands or fingers over the spray tip(s) while in operation.
- **Never** attempt to stop the rotating tubes and tips with your hands or any other object.
- **Never** tip the spinner backwards while in use.
- **Never** attempt machine repairs or adjustments while machine is hot.

- **Never** use any caustic chemicals or solvents as serious damage to the rotating union may result. If chemicals are used, a thorough flushing with clean water should immediately follow.
- **Never** point the spray gun, when used in conjunction with the pressure washer's lance and spray tip, at other persons or at any part of the body.
- **Never** attempt to push machine over hose while tubes are spinning.
- **Never** use the spinner on any uneven surfaces as this could cause serious damage to the machine and the operator.
- **Always** shut off the pressure washer and trigger the pressure gun to relieve system pressure before removing the spray tips or before performing any machine service.
- **Never** operate the machine if any vibration is present.
- **Never** run over bags, cups, paper, or other debris or trash.
- **Never** alter or modify this equipment! Your personal safety as well as the safety of other persons is at stake.
- **Always** wear full eye protection, protective clothing, gloves and rubber boots when operating the machine to protect yourself from burns caused by hot spray, fluid injection or debris dislodged by high pressure spray.



Discharge Hose Warning

The discharge hose supplied with the machine is designed for use on high pressure cleaners and accessories. Special care, handling and maintenance are required to provide proper and safe operation. The following guidelines must be followed to ensure safe operation and provide maximum hose service life.

- **Always** operate the machine on level and horizontal surfaces. Never try to use machine on vertical or pitched surfaces such as walls or roofs.
- **Always** replace spray tubes with factory authorized replacements when necessary.
- **Never** leave an operating machine unattended. Always shut off the machine and relieve pressure before leaving the machine.
- **Always** keep guards or shields in place. Replace any that that must be removed for service or that may be damaged.
- **Do Not** attempt repairs or modifications you do not understand. Contact your servicing dealer or contractor.
- **Never** exceed the factory pressure or temperature rating of the spinner.
- **Never** operate the spinner unless the orifice size of a spray tip in the spinner, multiplied by the number of tips in use by the spinner, is equal to or greater than that required to operate the pressure washer at its manufacturer's rated specifications.
- **Never** operate the Spinner with different orifice size spray tips.
- **Never** operate the spinner if one or more spray tips are plugged or if spray tubes are damaged.
- **Never** allow the spinner to operate in one spot for extended length of time. Damage to the surface may occur.

- **Do Not** route hose in a manner that will cause sharp bending, kinking, cutting, abrasion or other exterior damage.
- **Do Not** use the hose if cuts, leaks, abrasions, bulges or coupling damage is evident.

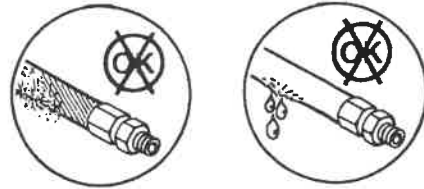

- **Do Not** attempt field repairs through an unauthorized hydraulic hose repair shop. Special coupling and crimping specifications are required for steam and high pressure washer discharge hose. Contact a qualified pressure washer service representative for repair of damaged hose.
- **Always** examine hose couplings and quick disconnects (if used) before each operation. If leaking is evident, **do not use**. Contact a qualified pressure washer service representative.

Specifications

For the Deublin Union

PRESSURE	4000PSI
MAX. FLOW	8 GPM
MIN. RECOMMENDED PRESSURE	1500 PSI
MIN. RECOMMENDED FLOW	4 GPM
MAX TEMPERATURE (°F)	210 (°F)
RPM	2000
CLEANING PATH	24"
DIMENSIONS	
Length	55"
Width	24 1/2"
Height	50
Approx. Weight (LBS)	50

Set-Up and Operating Information



For Your Safety and the Safety of Others, Study This Manual Before Operating or Servicing the Machine.

Machine Delivery Inspection

Examine the shipping carton and machine carefully for hidden damage during shipping. Claims for damage or shortage should be filed with the contract carrier. Remove all loose parts and strapping attached to the machine for shipping purposes.

Machine Identification

The machine serial number is on a plate permanently attached to the Spinner. Record the serial number from this plate for any future reference.

SERIAL # _____

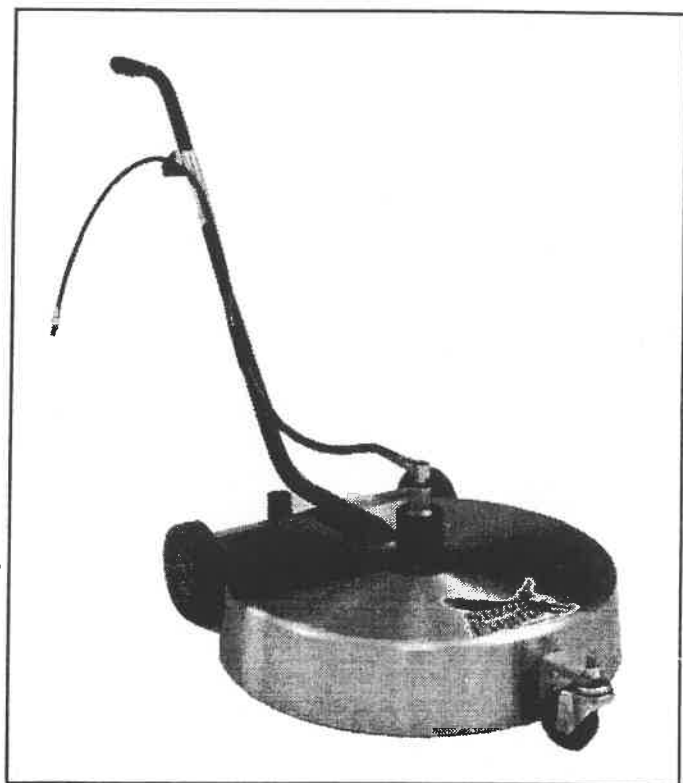

Machine Location

The Spinner is designed to be used in conjunction with a hot or cold high pressure washer to quicken the cleaning of large level surfaces. It is not designed for use on vertical or pitched surfaces such as walls or roofs.

Set-Up and Operating Information

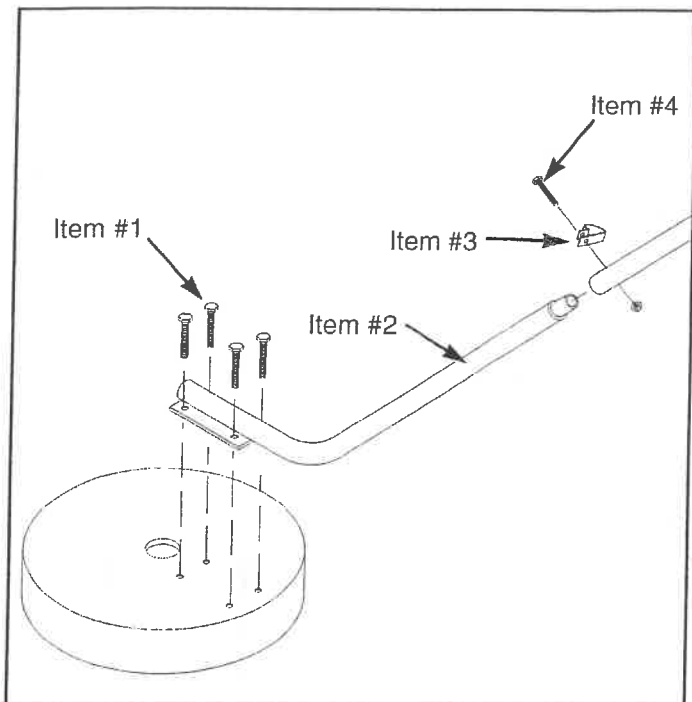

Figure #1 Handle Assembly

Item List:

- 4 - 1/4" x 3/4" Bolts and Nuts
- 1 - 1/4" x 1 1/2" Bolt and Nut
- 1 - Spinner Deck with Wheels and Union Assembly.
- 1 each - Upper and Lower Handle
- 1 each - Hose Restraint Fitting



IMPORTANT: *The spinner is supplied with (2) 15° #2.5 orifice spray tips. Be sure that this size is compatible with the flow and pressure specifications of your pressure washer. **Never** allow the spinner to be used if the orifice size in the Spinner, multiplied by the number of arms in use, (in this case 2 x #2.5 orifices equal a #5) is less than the orifice size required to operate the pressure washer at its manufacturers specifications. Serious personal injury as well as damage to the pressure washer may result if over pressurization occurs.*

Machine Assembly

1. Tools needed: 7/16" socket & wrench.
2. Remove all parts from the carton and verify contents against the item list. If any shortages, contact your seller.
3. (Figure #1) Install and secure handle base (Item #2) onto Spinner deck using (Item #1) 4 1/4" x 3/4" bolts and nuts.
4. (Figure #1) Attach upper handle to lower handle using (Item #4) the 1/4" x 1 1/2" bolt and nut. Also, attach (Item #3) the hose restraint fitting to the hose and attach it to the upper/lower handle assembly.

Recommended Machine Set-up

1. Remove the lance that is attached to your trigger gun and install a 1/4" quick coupler into the trigger gun outlet.
2. Connect a 1/4" quick coupler plug on the high pressure hose of the spinner to the 1/4" quick coupler on the trigger gun.

Machine, Start-up and Use

1. Start the pressure washer, being sure to follow all manufactures instructions concerning start-up.
2. Begin walking with the trigger gun in one hand and pushing the spinner with the other. Walk at a pace that allows the Spinner enough time to clean as thoroughly as you require.

Set-Up and Operating Information

Operating Tips and Procedures

1. Identify the surface that is to be cleaned.

There are many different types of surfaces that can be cleaned with the Spinner. Therefore it is very important that before you begin, you properly identify the surface that is to be cleaned. Each surface has its own characteristics that must be taken into account. A typical example would be the difference between a multi-level parking garage and a cement patio. Both are cement, but the parking garage cement typically is three times as strong as the patio. Therefore, if you are using a very high pressure washer, damage to the softer concrete may result. In order to avoid what could be a costly mistake, always perform thorough identification and inspection procedures.

There are a number of other items that you must be aware of when inspecting the job site. Potential problem areas must be identified before beginning work, such as cracked or fractured surfaces, anchor bolts, holes, rocks, uneven surfaces, etc. Any one of these can cause damage to the Spinner. Therefore, it is recommended that you identify potential problem areas and mark them so that you can avoid these areas and possible damage to your Spinner.

2. Identify the type of soil to be removed.

In order to maximize the performance of the Spinner, you must properly identify the type of soil that is to be removed. Typical sidewalk soils such as soda pop, candy and food would require minimal chemical preparation as opposed to degreasing a parking space which would typically require a presoaking with an industrial degreaser. No matter what the circumstances are, thorough identification is important.

3. Determine if a chemical is necessary and if so, which chemical is right for the job.

Once you have determined the type of surface and soil, you must determine if a chemical treatment is necessary. If a chemical is in fact necessary to loosen soil, be sure to include it in the test patch which will be discussed in section 5. Once again it is very important to identify the soil and prepare the surface with the proper chemical as this will assist you in maximizing the performance of the Spinner.

4. Chemical application.

There are two methods of applying chemicals to surfaces. The most common method is by utilizing a Hudson sprayer or something comparable. This method allows the highest concentration of chemical to be applied directly to the soiled areas. The second method is by pumping the chemical through the Spinner forcing the chemical onto the soil under high pressure. Either method is acceptable and results will vary from job to job. If you choose to run chemical through the Spinner, you must flush the system for at least 5 minutes with clean water in order to make certain that there is no chemical remaining in the union. Failure to thoroughly clean the system can cause substantial damage to the union and void the warranty. The use of any acids through the Spinner also voids the warranty.

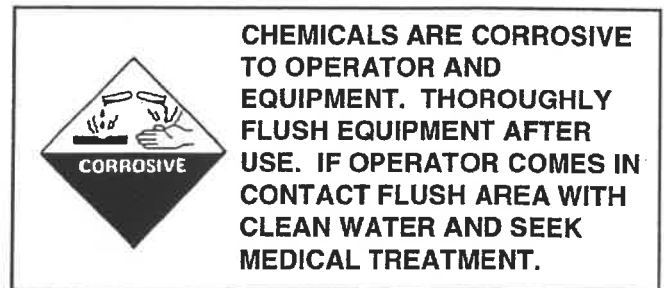

5. Perform a test patch.

Once you have all the information necessary to proceed, pick a small inconspicuous area to perform a test patch. When choosing the test area, make certain that it is consistent with the general area to be cleaned. Next, connect the high pressure hose from the Spinner to the port of the trigger gun. Pull the trigger to establish flow. With a smooth and steady motion, walk slowly forward approximately 5 feet. Release the trigger assembly and inspect the surface.

REMEMBER: You must include all factors when performing a test. Do not forget to turn on the burner if using hot water. Also apply chemical if inspection determined it is necessary.

Set-Up and Operating Information

Operating Tips and Procedures

6. Establish cleaning pattern.

Just as you would create a pattern when mowing a lawn, you should create a pattern with the Spinner. There are several factors that you must take into consideration when determining the starting point.

- A) Establish a pattern that allows water to flow away from the immediate work area. This will eliminate as much standing water as possible.
- B) If possible, start at the highest point and work toward the lowest point. **Do not attempt to operate the Spinner through standing water as the effectiveness of the spray is dramatically reduced and possible damage to the Spinner could result.**

Helpful Hints:

1. Try and route the hose so it is always to your back. This will eliminate having to constantly move it out of the way.
2. As you complete your first pass, you will most likely turn around and parallel that path back to the starting point. If you turned to the left at the end of the first path, turn right at the end of the second path. This will keep your hose from coiling up.
3. An inline swivel between the hose and the inlet to the gun eliminates most of the coiling problems.

7. Set up.

In order to utilize the features to their full extent, you should set up your equipment in the following manner.

Insert a 1/4" quick coupler on the outlet of the pistol and a 1/4" quick coupler nipple on the inlet end of the lance. This will allow you to completely disconnect from the Spinner without having to shut down the pump. This also allows you to return to a conventional cleaning mode so that you can clean hard to reach areas such as staircases and corners. This design allows you to have full use of either the Spinner or the lance by releasing the trigger. Another reason that the gun is separate is because this design allows the operator to pull the hose with one hand and push the Spinner in an uninterrupted manner with the other hand.

Routine Maintenance



A Properly Maintained Machine Is A Safe Machine

It is the operator's responsibility to make daily inspections of the machine for anything that could cause a potential service or safety problem.

Service & Maintenance Schedule

Preventative maintenance is the easiest and least expensive type of maintenance. The life of any machine depends on the care that it is given. Regular inspections of the machine's systems and critical components is the key to preventative maintenance. To prevent machine down time and prolong the life of your unit, follow these simple routines.



Daily

- Check spray tubes for bending or damage.
- Check spray angle setting with gauge. Adjust if necessary.
- Check wash nozzles for clogging or damage.



Weekly

- Check pressure hose for wear or damage.
- Check quick couplers for leakage (if used).
- Check in-line swivel for leakage (if used).
- Check wheels and grease when necessary.

Union Maintenance

Chevron SRI grease is the recommended grease for union maintenance. Lubrication requirements are .12 ounces of grease (3.5 grams) every 5000 hours.

The union is pre-greased from the factory so the first lubrication is required at 5000 hours.

IMPORTANT

OVER GREASING CAN CAUSE HIGHER TORQUE AND SLOW DOWN THE ROTATION OF THE WASH WAND. TOO MUCH GREASE IS WORSE THAN NOT ENOUGH. THIS DESIGN PROTECTS THE BALL BEARINGS FROM MOISTURE THROUGH THE USE OF LABYRINTH SEALS, SO FREQUENT LUBRICATION IS NOT REQUIRED.



**5000
Hours**

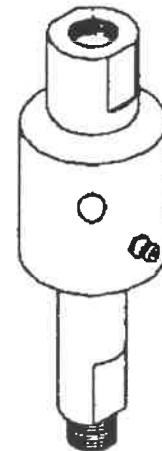

Routine maintenance

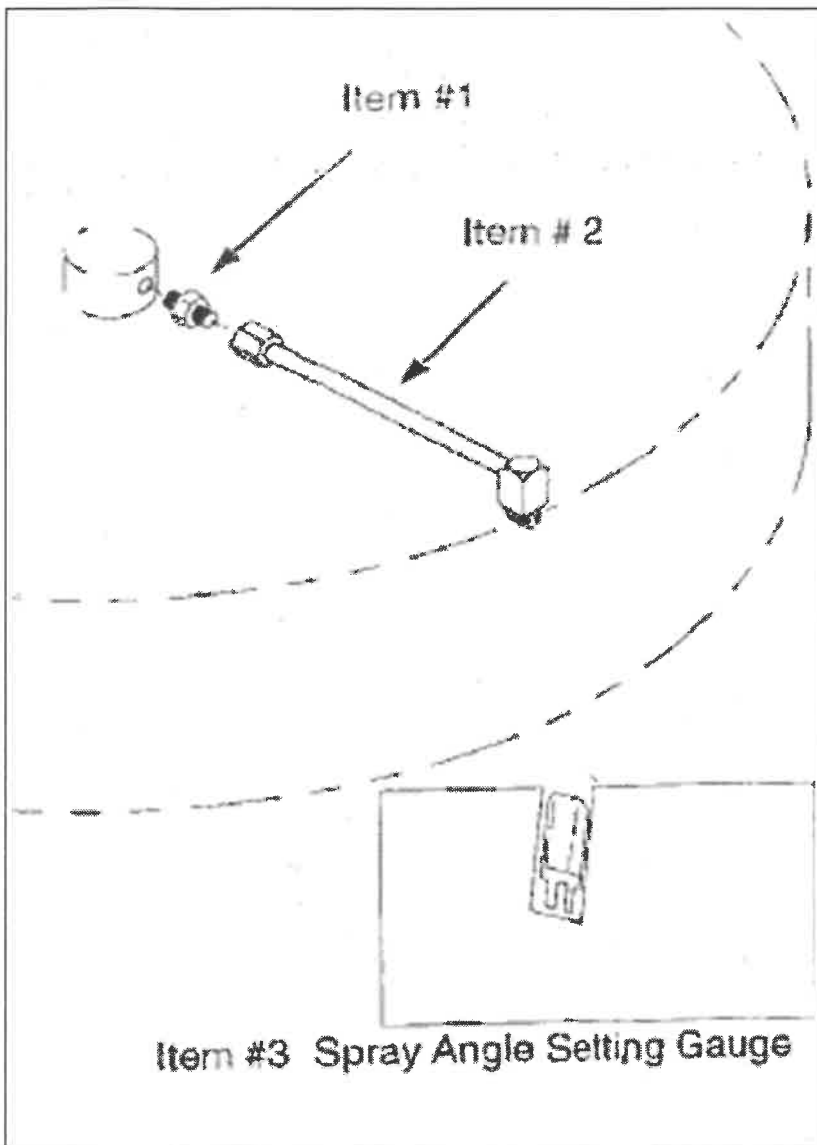

CHECK WEBSITE FOR SPRAY TIP GAUGE SETTING
VIDIEO ON HOW TO SET SPRAY ARMS.
www.steeleagle.com

Figure #1 Spray Arm Assembly & gauge for 3&4 bar surface spinners

Spray Arm replacement

1. **(Figure # 1)** Turn the spinner on its side. Install the O-Ring side on the Ferrule fitting (**Item # 1**) into the manifold using 11/16" wrench. When tightened, the O-ring provides the seal so no additional sealant is required.
2. Attach the spray arm assemblies (**item # 2**) to the fitting. Use the spray angle setting gauge (**item # 3**) to position the spray setting and tighten the fitting when the top of the gauge is flush with the spinner deck and the spray tip angle matches the gauge.

Troubleshooting



WARNING: Before Attempting Any Repairs or Maintenance, Be Sure Machine is Shut Off and Disconnected from Main Pressure Washer.

Troubleshooting

Troubleshooting is an organized study of the problem and a planned method of procedure for investigation and correction of the difficulty. The following troubleshooting guide includes some of the problems that you may encounter during the service life of the machine.

This troubleshooting guide does not give all the answers for correction of problems listed, but are meant to stimulate a train of thought and indicate a work procedure directed toward the source of the trouble.

THINK BEFORE ACTING

Study the problem thoroughly and ask yourself these questions:

1. What are the warning signs preceding the trouble?
2. What previous repair and maintenance work has been done?
3. Has a similar problem occurred before?
4. If the machine still runs, is it safe to continue operating to make further checks?

DO THE EASIEST THING FIRST

Most problems are simple and easily corrected.

Example: "Nozzles will not spin."

Complaint caused by plugged nozzles or improper angle.

Always check the easiest and obvious things first. Following this simple rule will save time and trouble.

FIND AND CORRECT BASIC CAUSE OF TROUBLE

AFTER A MECHANICAL FAILURE HAS BEEN CORRECTED, BE SURE TO LOCATE AND CORRECT THE CAUSE OF THE PROBLEM SO THAT THE SAME FAILURE WILL NOT BE REPEATED.

The following pages list some of the problems, causes and probable fixes the operator can study to become aware of what might cause the problem should it arise.

If the hints in this manual do not correct a problem, contact a dealer or authorized service representative. **DO NOT** attempt repairs you do not understand.

Troubleshooting

PROBLEM	PROBABLE CAUSE	POSSIBLE REMEDY
1. Machine Vibrates	<ol style="list-style-type: none">1. Nozzle's set improper angle2. Plugged nozzle's3. Bent tubes4. Worn or damaged union5. Different size spray nozzle.6. Wheels or wheel brackets are loose or damaged.	<ol style="list-style-type: none">1. Set nozzle's to proper and equal setting.2. Remove nozzle, inspect for debris, remove obstruction, replace nozzle.3. Inspect manifold assembly for damaged tubes. Replace damage tubes if necessary.4. Inspect union for play in the shaft. Replace union if necessary.5. Make sure nozzle's are of equal orifice size.6. Inspect and repair as necessary
2. Nozzles will not spin	<ol style="list-style-type: none">1. Nozzle's set at improper angle2. Plugged nozzle's3. Rotating union has failed.4. No pressure to spinner	<ol style="list-style-type: none">1. Set nozzle's to proper and equal setting.2. remove nozzle's, inspect for debris, remove obstruction , replace nozzle.3. Inspect union and replace as necessary.4. Check for pressure at pressure washer
3. Spinner will not turn	<ol style="list-style-type: none">1. Debris has attached to front wheel .2. Lack of adequate lubrication.	<ol style="list-style-type: none">1. Inspect wheel for rock or other foreign objects.2. Grease rear wheel

BILL OF MATERIALS

ITEM	QTY	PART DESCRIPTION	PART \ DRW#
1	1	HANDLE ASSEMBLY	BNH-0001
2	1	WHEEL BRACKET ASSEMBLY	ESE-0008
3	1	DECK ASSEMBLY	ESE-0030
4	1	DECAL PACKAGE	ISE-0006
5	1	PACKAGING ASSY	JNH-0001

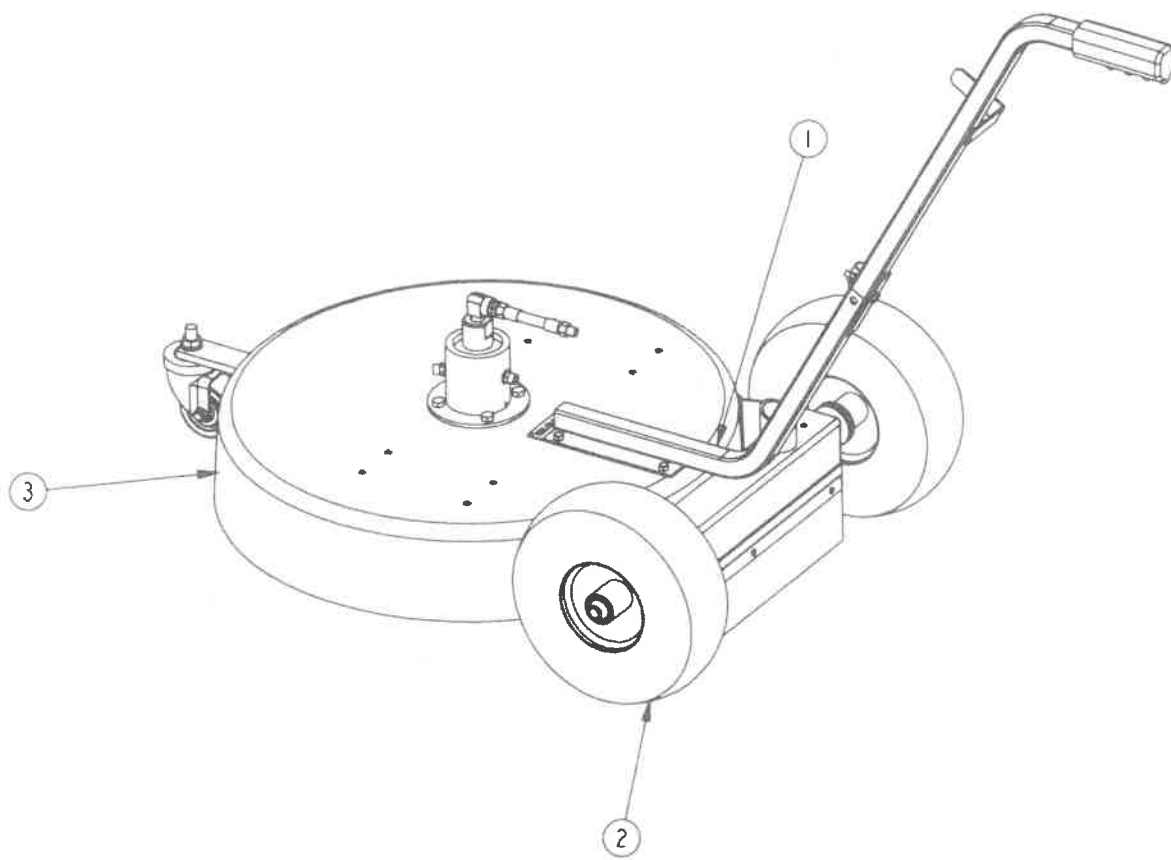

TITLE	SPINNER	
DESCRIPTION	24" DEUBLIN	
	13-Apr-04	DWG# ASE-0003

ITEM	NUMBER	DESCRIPTION	QTY.
1	01-131204	ELBOW, ST. 3/8" X 90° HD	1
2	01-171500	UNION	1
3	01-171501	BRASS WASHER	1
4	01-221104	COUPLING, 3/8" PLATED	1
5	02-111200	CAP SCREW, 1/4-20 x 1 HEX	2
6	02-131200	CAP SCREW: 3/8"-16 x 1"	4
7	02-301130	NUT, HEX: NYLK 1/4"-20 ZINC	2
8	02-301331	HEX NUT - NYLK 3/8-16	4

ITEM	NUMBER	DESCRIPTION	QTY.
9	02-522100	POP RIVET	2
10	06-100460	SPRAY JET	2
11	26-101002	DECAL: SPINNER SERIAL #	1
12	29-143000	MANIFOLD 2-PORTS SPINNER	1
13	BF-0029	HOSE	1
14	BSE-0032	UNION MOUNT	1
15	BSE-0109	SPINNER DECK-DRILL PATTERN	1
16	ESE-0006	SPINNER PART 24" DEUBLIN	2
17	ESE-0036	CASTER ASSEMBLY	1

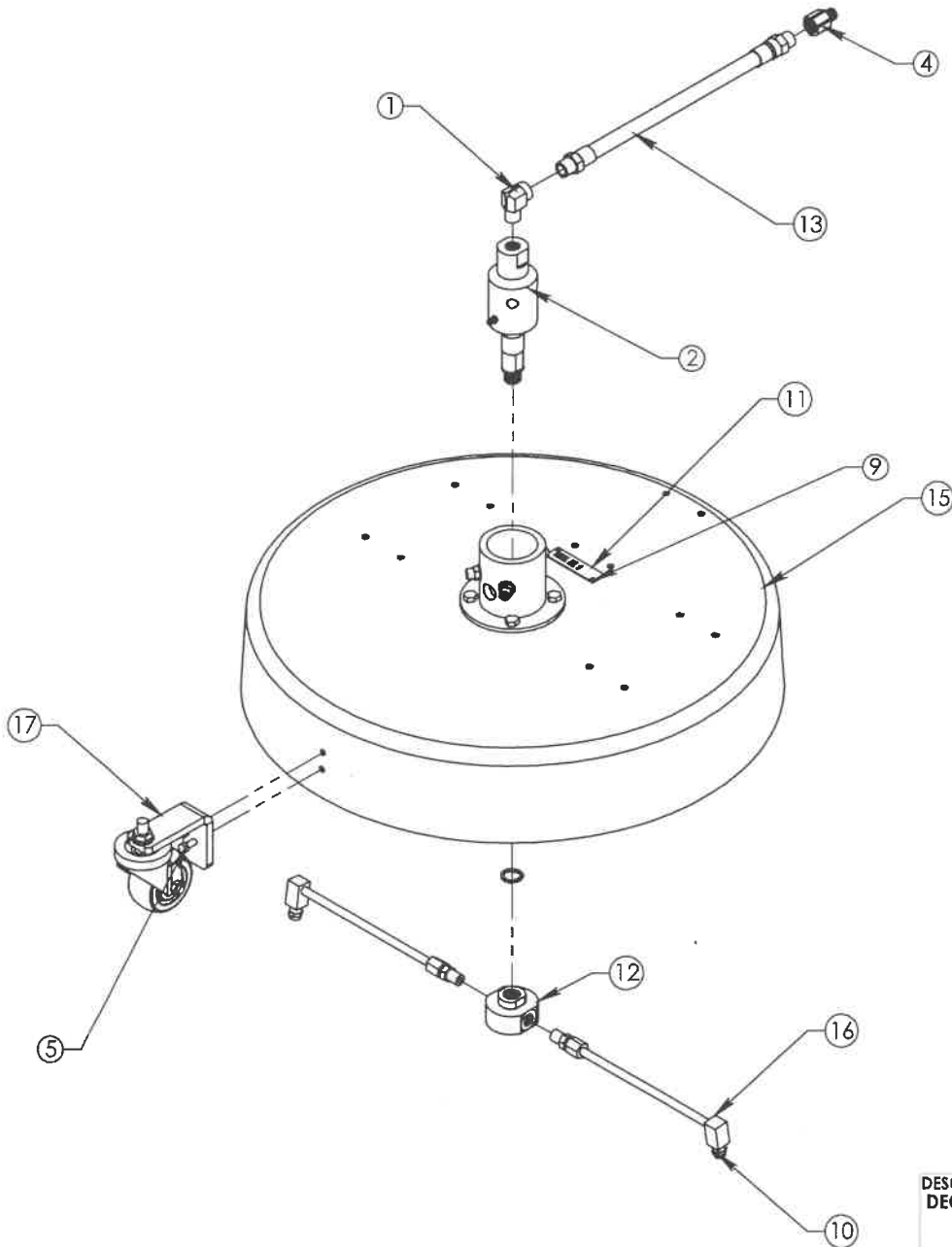

DESCRIPTION:
DECK ASSEMBLY

DESCRIPTION 2:
24" DEUBLIN

DRAWN BY:

DATE:
4/13/2004

DRAW #:
ESE-0030

ITEM	NUMBER	DESCRIPTION	QTY.
1	02-111100	CAPSCREW, 1/4-20 x 3/4	8
2	02-111500	CAPSCREW: 1/4-20 X T 3/4 ZINC PLATED	2
3	02-301130	NUT, HEX: NYLK 1/4"-20 ZINC	10
4	03-191220	CLAMP	1
5	blk-0010-2	U-HANDLE WELDMENT	1
6	BLK-0011	LOWER TUBE WELDMENT	2

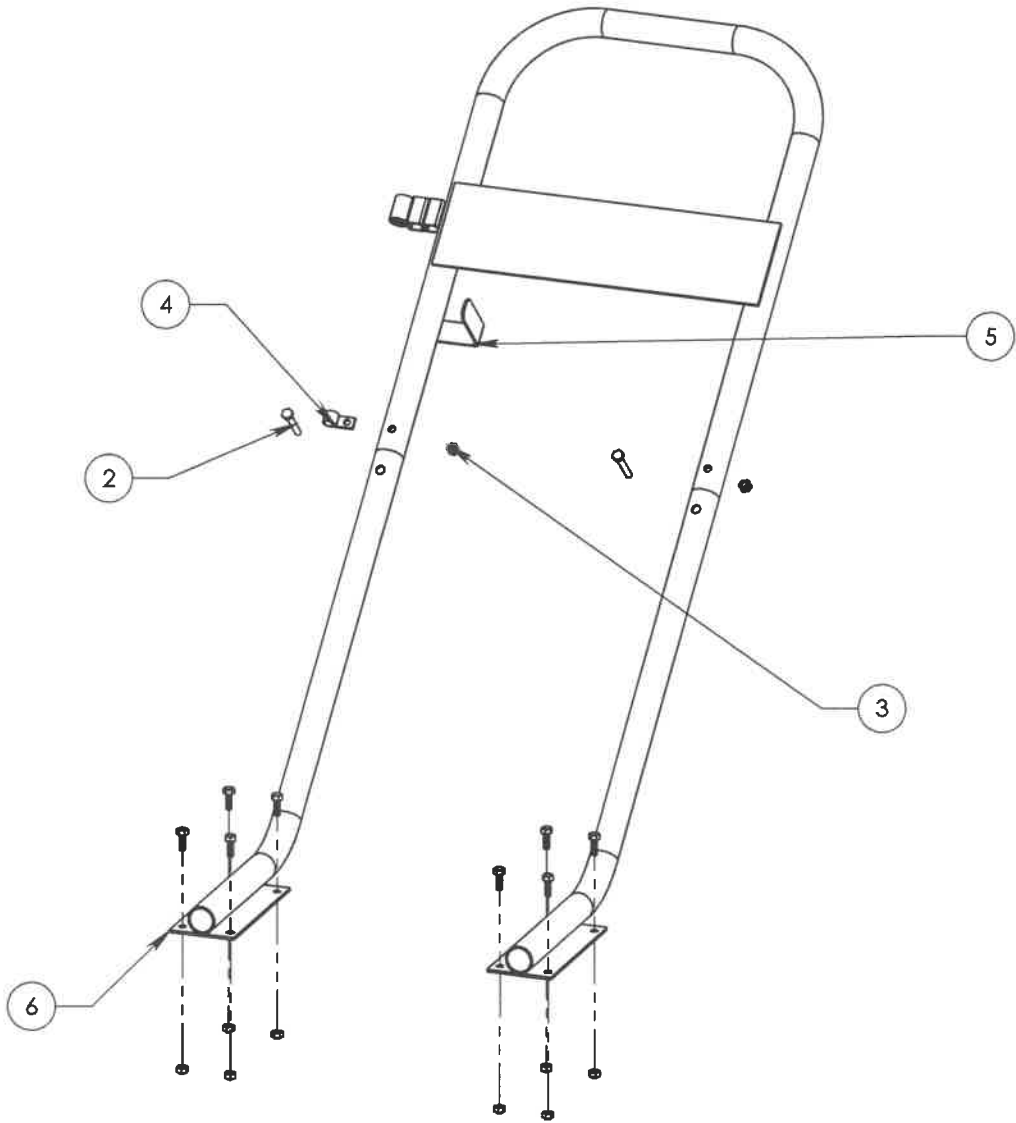

REV.	DESCRIPTION	DATE	BY
A	REMOVED BLK-0010; ADDED BLK-0010-2	3/12/2018	NS
REVISIONS			

DRAWN BY: NS
 DATE: 1/20/2011
 DESCRIPTION: U HANDLE ASSEMBLY, 24" & 30"
 DESCRIPTION 2: U-HANDLE
 DRAW #: blk-0001

BILL OF MATERIALS			
ITEM	QTY	PARTS DESCRIPTION	PART #
1	1	NUT 1/2" SRTD WHIZLOCK	02-301400
2	1	CASTER 3 1/2"	12-101200
3	1	CASTER BRACKET	BNH-0002

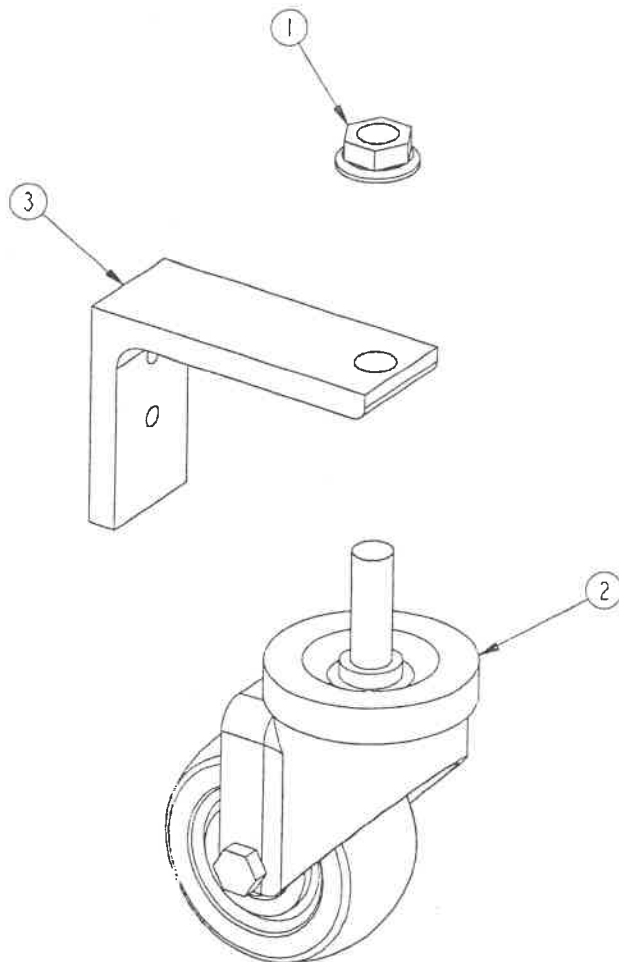

24" CASTER BRACKET ASSEMBLY			
24" SPINNER			
PART # E01-0001			

BILL OF MATERIALS

ITEM	QTY	PART DESCRIPTION	PART #
1	3	5/16" X 3/4"	02-121103
2	3	5/16" NUT	02-301200
3	1	GASKET	02-505000
4	1	UNION MNT. WELDMENT	BSE-0089
5	1	SPACER	BSE-6113

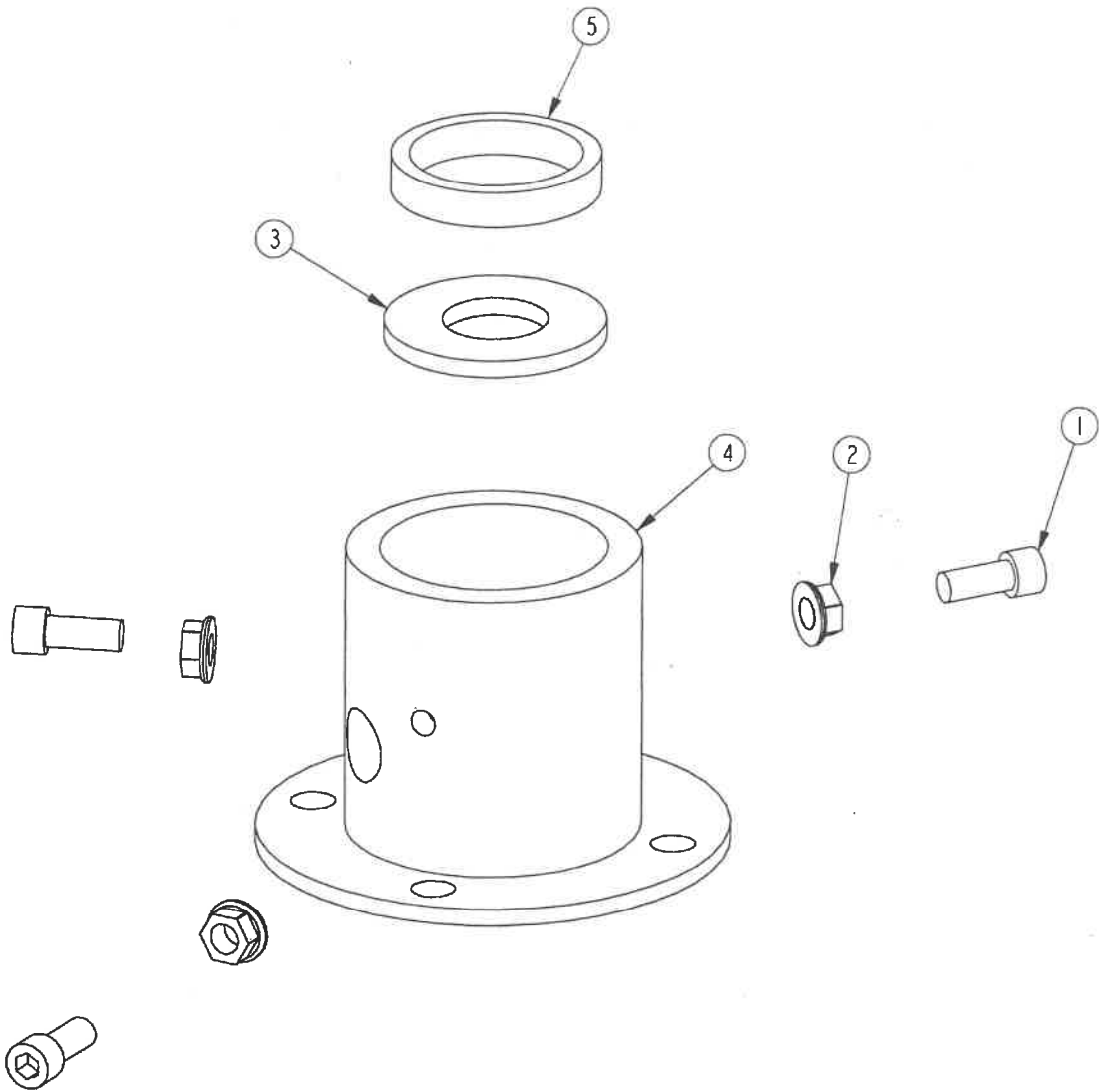

UNION MOUNT ASSEMBLY

DEUBLIN SPINNER

PART # BSE-0032

ITEM	NUMBER	DESCRIPTION	QTY.
1	02-111100	CAPSCREW, 1/4-20 x 3/4	5
2	02-301130	NUT, HEX: NYLK 1/4"-20 ZINC	5
3	02-521203	PUSH CAP NUT 3/4" - AXLE CAP	2
4	02-522200	POP RIVET	3
5	1003-P56	PIPE: 3/4" SCH 40 BLACK	2
6	12-152000	WHEEL 410x 350x 4" FLAT FREE	2
7	BSE-0015	GUN HOLDER WELDMENT	1
8	BSE-0055-1S	24" REAR BRACKET (3.50 X 4 WHEEL)	1
9	BSE-0057	24" EDGE STRIP	1
10	BSE-0088	PLASTIC BLADE	1
11	BSE-6114-1	AXLE - 24 3/4"	1

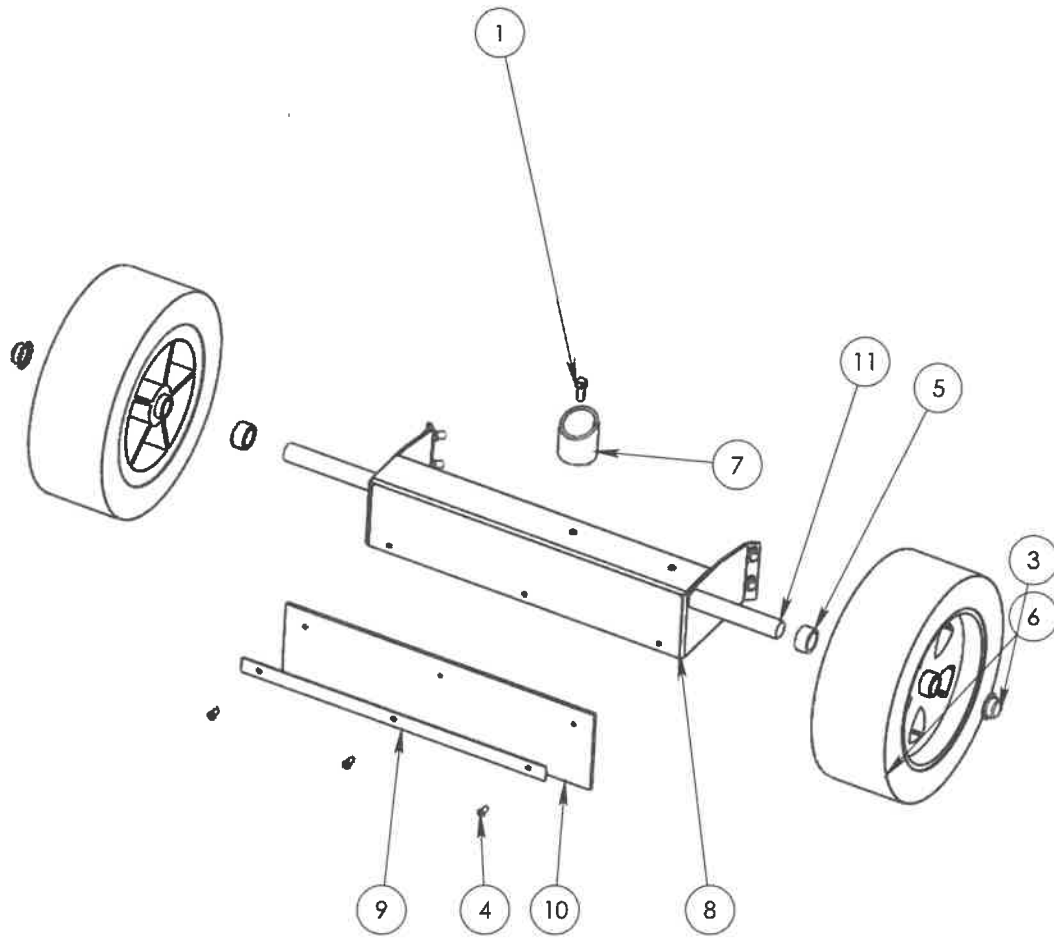

REV.	DESCRIPTION	ECR/ECN	DATE	BY
B	BSE-0055-1S WAS BSE-0055-1		12/28/2015	NS
A	DELETED 02-501700, ADDED 1003-P56		9/2/14	LG
REVISIONS				

DRAWN BY:	DATE:
REV: -.02	4/05/13
SHEET 1 OF 1	

DESCRIPTION:
WHEEL BRACKET ASSY

DESCRIPTION 2:
24" SPINNER

DRAW #:
ESE-0008-1

WARRANTY

We warranty each new unit and part sold by us to be free from manufacturing defects in normal service for a period of (1) year commencing with delivery of the product to the original owner. Copy of the original bill of sale, including serial number must accompany claim.

Our obligation under this warranty is expressly limited at our option, to the replacement or repair at a facility designated by us, of such part or parts as inspection shall disclose to have been defective. This warranty does not apply to defects caused by damage or unreasonable use (including failure to provide reasonable and necessary maintenance) while in the possession of the customer. THIS WARRANTY DOES NOT APPLY TO HARDWATER DAMAGE, NOZZLE WEAR, PAINT OR IMPROPER CHEMICAL USE.

WE SHALL NOT BE LIABLE FOR CONSEQUENTIAL DAMAGE OR ANYTHING, including but now limited to, consequential labor costs or transportation charges in connection with the replacement or repair of defective parts.

ANY IMPLIED OR STATUTORY WARRANTIES, INCLUDING ANY WARRANTY OR MERCHANTABILITY OR FITNESS FOR A PARTICULAR PURPOSE, ARE EXPRESSLY LIMITED TO THE DURATION OF THIS WRITTEN WARRANTY. We make no other express warranty, nor is anyone authorized to make it on our behalf.

**Steel Eagle
32586 477th Ave.
Elk Point, SD 57025**



Steel Eagle, Inc.
32586 477th Ave
Elk Point, SD 57025

(800) 447-3924
Fax: (605) 356-2144

info@steeleagle.com
www.steeleagle.com