

**OPERATOR'S MANUAL  
ELECTRIC HIGH-PRESSURE WASHER**

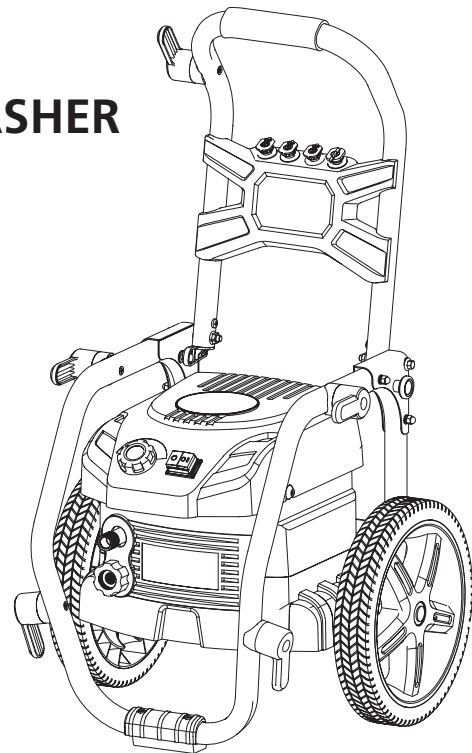

**Before operating this product, please read this manual thoroughly and retain it for future reference.**

**SUMEC NORTH AMERICA  
3939 Royal Drive NW  
Unit #234  
Kennesaw, GA 30144**

**DO NOT RETURN PRODUCT TO PLACE OF PURCHASE.  
IF YOU HAVE ANY QUESTIONS, CALL OUR TOLL-FREE HOTLINE.**

**(866) 902-9690**

**ForceToolsUSA.com**

# YARD FORCE

## YF2200BL Operator's Manual

### TABLE OF CONTENTS

Description of Product Parts.....	02
Technical Specifications.....	04
Intended Use.....	04
Important Safety Instructions.....	05
Installation Instructions.....	10
Operating Instructions.....	15
Cleaning and Maintenance.....	19
Moving and Storage Instructions.....	20
Disposal.....	21
Troubleshooting.....	21
Warranty.....	24

## DESCRIPTION OF PRODUCT PARTS

### Parts list

As shown in Fig. 1-3

1. Gun / power cord / hose holder
2. Handle with soft grip
3. Spray tips storage slots
4. Pressure adjusting knob
5. Support
6. High-pressure water outlet
7. Water inlet
8. Locking/releasing pin (not visible in this illustration)
9. On / Off Switch
10. Wheel
11. Plug
12. Power cord with GFCI
13. Attachments storage
14. Detergent intake hose
15. Nozzle cleaning needle
16. High-pressure hose
17. Quick-connect wand
18. Spray gun high-pressure water inlet
19. Trigger switch
20. Safety lock
21. Trigger handle
22. 0° nozzle
23. 15° nozzle
24. 40° nozzle
25. Soap nozzle
26. Turbo nozzle
27. Nozzle cleaning needle

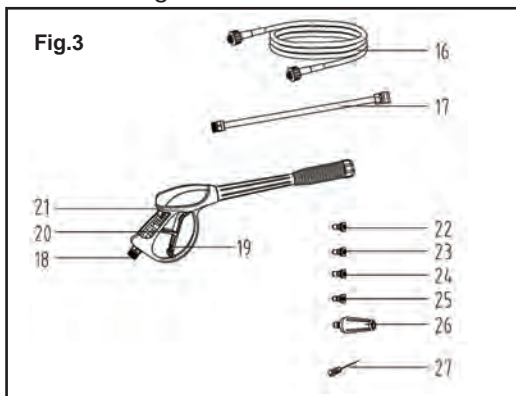
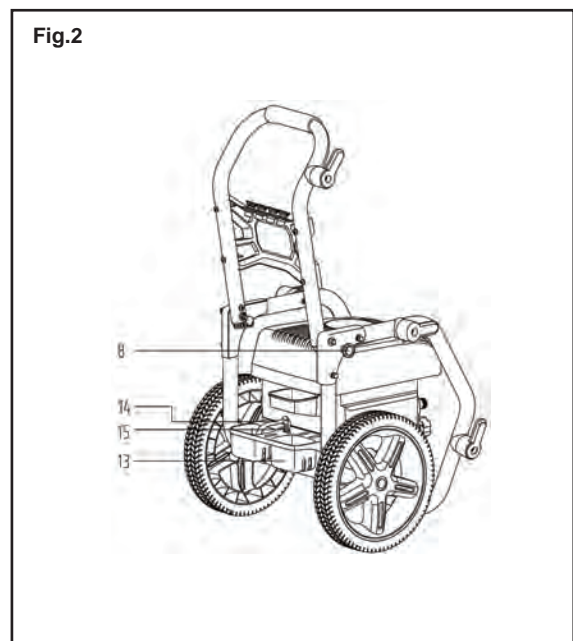
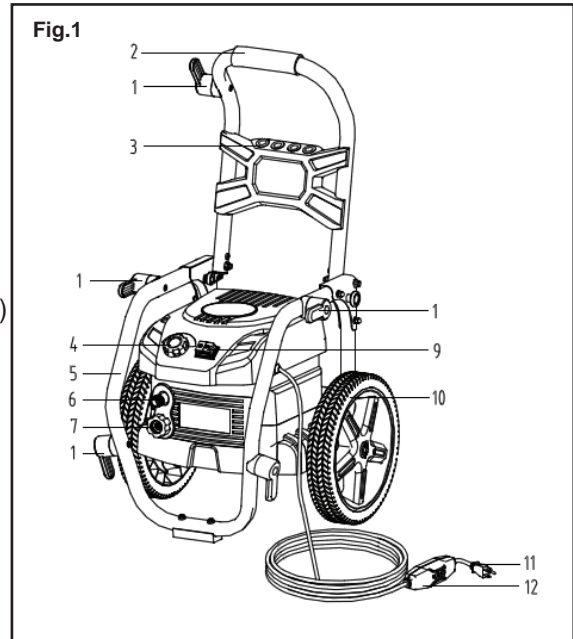

## CHECK THE DELIVERY PARTS

As shown in Fig. 4

Carefully remove the pressure washer and parts from its packaging. Identify all the parts packaged in the carton against the parts list. Please contact our customer service center (Monday-Friday 8:30AM-5:00PM ET) at (866) 902 9690 if anything is missing.

- A High-pressure washer x1
- B High-pressure hose x1
- C Quick-connect wand x1
- D Trigger handle x1
- E1 0° nozzle x1
- E2 15° nozzle x1
- E3 40° nozzle x1
- E4 Soap nozzle x1
- E5 Nozzle cleaning needle x1
- F Nozzle pin x1
- G Operating manual x1

**! WARNING:** If any parts are damaged or missing, do not operate this tool until the missing parts are replaced. Failure to heed this warning could result in serious personal injury.

**! NOTE!** Always recycle the packaging in accordance with local recycling schemes.

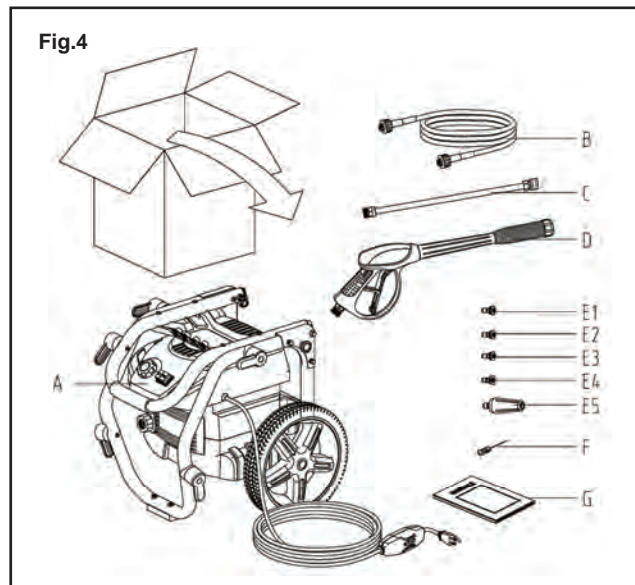

## TECHNICAL SPECIFICATIONS

<b>Model</b>	<b>YF2200BL</b>
Input voltage rating	120 V, 60 Hz
Input power	13 A
Working pressure	2200psi
Max. pressure	2500psi
Flow rate	1.25GPM (280L/H)
Inlet pressure	44psi
Supply water temperature (max.)	Cold tap water 104°F (40°C)
Electrical cord	35ft. (10.7m)
High-pressure hose	25ft. (7.6m)
Detergent injection rate	3%~12%

## INTENDED USE

The pressure washer is intended for cleaning the walls of buildings, facades, terraces, footpaths, garden equipment, machinery, vehicles, tools, etc. with a pressure water nozzle. If required, you can also use the pressure washer with added household cleaning agents.

The pressure washer is to be used only for its prescribed purpose, any other use is deemed to be a case of misuse. The user/operator and not the manufacturer will be liable for any damage or injuries of any kind caused as a result of this.

Please note that our equipment has not been designed for use in commercial, trade or industrial applications. Our warranty will be voided if the pressure washer is used in commercial, trade or industrial businesses or for equivalent purposes.

## IMPORTANT SAFETY INSTRUCTIONS

**Please read all of the safety precautions before operating this pressure washer every time.**

**Please pay particular attention to all sections with following symbols.**

The following signal words and meanings are intended to explain the levels of risk associated with this pressure washer.

### **DANGER!**

Indicates an imminently hazardous situation which, if not avoided, will result in death or serious injury.

### **WARNING!**

Indicates a potentially hazardous situation which, if not avoided, could result in death or serious injury.

### **CAUTION!**

Indicates a potentially hazardous situation which, if not avoided, may result in minor or moderate injury.

### **CAUTION!**

(Without Safety Alert Symbol) Indicates a situation that may result in property damage.

** WARNING!** - When using this pressure washer, basic precautions should always be followed, including the following:

1. Read all the instructions before using the pressure washer.
2. To reduce the risk of injury, close supervision is necessary when a product is used near children.
3. Know how to stop the pressure washer and release pressure quickly. Be thoroughly familiar with the controls.

4. Stay alert-watch what you are doing.
5. Do not operate the pressure washer when fatigued or under the influence of alcohol or drugs.
6. Keep operating area clear of all persons.
7. Do not overreach or stand on unstable support. Keep good footing and balance at all times.
8. Follow the maintenance instructions specified in the manual.
9. This pressure washer is provided with a Ground Fault Circuit Interrupter built into the power cord plug. If replacement of the plug or cord is needed, use only identical replacement parts.
10. This pressure washer or its power cord contains lead, a chemical known to cause cancer, birth defects or other reproductive harm. Wash hands after handling.

 **WARNING** - Risk of injection or injury – Do Not Direct Discharge Stream At persons.

11. Never operate the pressure washer without all components properly connected to the pressure washer (handle, gun/wand assembly, nozzle, etc.).
12. Never operate pressure washer with broken or missing parts. Check equipment regularly and repair or replace worn or damaged parts immediately.
13. Never put hand or fingers over the nozzle or spray tip while operating the pressure washer.
14. Never spray flammable liquids or use pressure washer in areas containing combustible dust, liquids or vapors. An electric spark could cause an explosion.
15. Never leave the wand unattended while the pressure washer is running or switched on.
16. Never disconnect the high-pressure discharge hose from the pressure washer while the system is pressurized. To depressurize washer, turn power and water supply off, then depress gun trigger 2-3 times.
17. Never cover the pressure washer during operation to allow free air cooling.
18. Always wear safety glasses or goggles when operating or performing maintenance.
19. Always move switch on washer to “OFF” position before connecting or disconnecting cord to electrical outlets.
20. Always turn water supply "ON" before turning pressure washer "ON" unless draining for storage. Running pump dry causes serious damage.
21. Always hold gun and wand firmly when starting and operating the pressure



- washer.
22. Always follow detergent manufacturer's label recommendations for proper use of detergents. Always protect eyes, skin and respiratory system from detergent if used.
  23. Always lock the trigger of spray gun in the safety position when not in use.
  24. Do not use pressure that exceeds the operating pressure of any of the parts (hoses, fittings, etc.) in the pressurized system. Never use with any other manufacturer's accessories or components.
  25. Do not spray electrical apparatus and wiring or the pressure washer itself.
  26. Do not operate the pressure washer with the inlet water filter removed. Keep filter clear of debris and sediment.
  27. Discharge residual pressure by depressing the trigger until no more water comes out of the nozzle.
  28. Keep clear of nozzle. Never direct high-pressure spray at any person, animal or self.
  29. To minimize the amount of water getting into the pressure washer, the pressure washer should be placed as far as possible from the cleaning site during operation.

## **GROUND FAULT CIRCUIT INTERRUPTER PROTECTION**

This pressure washer is provided with a ground fault circuit interrupter (GFCI) built into the plug of the power cord. This device provides additional protection from the risk of electric shock. Should replacement of the plug or cord become necessary, use only identical replacement parts that including of GFCI protection. TEST BEFORE EACH USE. Press the "TEST" button. Red indicator should disappear. Press "RESET" button again for use. DO NOT USE if above test fails.

## **EXTENSION CORDS**

If possible, do not use extension cords with this pressure washer; however, if you must use one, observe all of the warning and instructions listed below:

### **WARNING**

Extension cords are not recommended unless these are plugged into a ground fault circuit interrupter (GFCI) found in circuit boxes or protected receptacles.

1. Use only extension cords that are intended for outdoor use. These extension

cords are identified by a marking “Acceptable for use with outdoor appliances; store indoors while not in use.”

2. Use only extension cords having an electrical rating not less than the rating of the pressure washer.
3. Do not use damaged extension cords. Examine extension cord before using and replace if damaged.
4. Do not abuse extension cord and do not yank on any cord to disconnect. Keep cord away from heat and sharp edges.
5. Always disconnect the extension cord from the power source before disconnecting the pressure washer from the extension cord.

**⚠ WARNING** – To reduce the risk of electrocution, keep all connections dry and off the ground. Do not touch plug with wet hands.

**⚠ WARNING**  
**RISK OF INJURY**  
**INJECTION HAZARD**

1. Equipment can cause serious injury if the spray penetrates the skin. Do not point the gun at anyone or any part of the body. In case of penetration, seek medical aid immediately.
2. This system is capable of producing 1885psi. To avoid rupture and injury, do not operate this pump with components rated less than 1885psi working pressure (including but not limited to spray guns, hose, and hose connections).
3. Before servicing, cleaning, or removal of any part, switch off power and relieve pressure.

**⚠ WARNING**  
**RISK OF INJURY**  
**DO NOT DIRECT DISCHARGE STREAM AT SELF OR OTHER PERSONS.**

1. High-Pressure jet can be dangerous if misused.
2. The jet must not be directed at persons, animals, electrical devices, or the unit itself.

 **WARNING****RISK OF EXPLOSION-DO NOT SPRAY FLAMMABLE LIQUIDS**

Do not use acids, alkaline, solvents or any flammable material in this product. These products can cause physical injuries to the operator and irreversible damage to the pressure washer.

 **WARNING****RISK OF ELECTRIC SHOCK**

1. Inspect cord before using –Do not use if cord is damaged.
2. Keep all connections dry and off the ground.
3. Do not touch plug with wet hands.

 **CAUTION****GUN KICK BACK**

1. Hold with both hands.
2. The trigger gun safety lock prevents the trigger from being engaged accidentally.
3. The safety feature does not lock trigger in the ON position.

 **CAUTION**

This pressure washer has been designed for use with detergents that are specifically approved for pressure washer use. The use of other cleaning detergents may affect the operation of the pressure washer and void the warranty.

## INSTALLATION INSTRUCTIONS

### **WARNING!**

Remove power cord from power source before carrying out any work on the equipment, and use only original parts.

Before starting any cleaning task, it is important to inspect the area for objects that could create a hazard. Remove any objects from the work area that could be tripped over, such as toys or outdoor furniture. Ensure that all doors and windows are closed tightly.

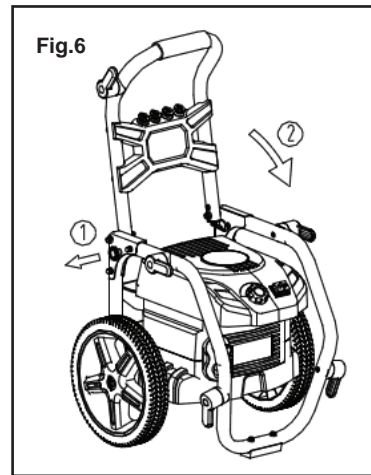
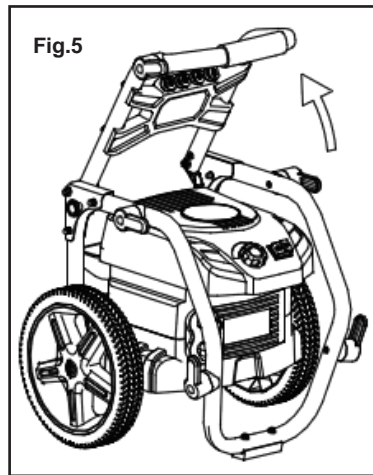

### **Unfold the handle** **As shown in Fig. 5 & 6**

Turning the handle upward around 100°, until the locking/releasing pin engages into the corresponding hole on the handle.

Make sure the handle was fixed securely before each using.

To fold the handle:

Pull the locking/releasing pin outward on the right side of the pressure washer, and turn the handle downward to fold the handle.

## Connect the hose to the pressure washer

### As shown in Fig. 7

Attach high-pressure hose to the washer's water outlet (hand tighten only).

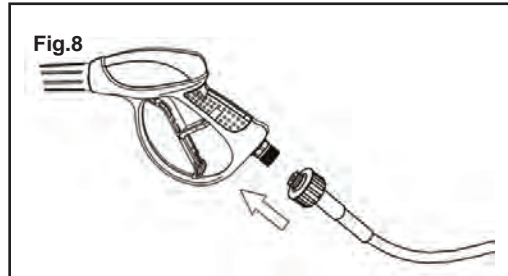
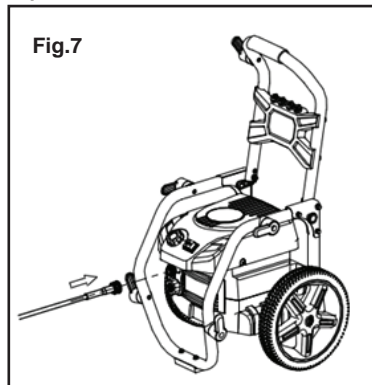

## Connect the hose and spray gun

### As shown in Fig. 8

Screw the high-pressure hose firmly onto the spray gun.

## Fit the spray nozzles to spray gun

### As shown in Fig. 9

Attach desired color coded spray tip to quick-connect wand by pushing to ensure it is clicked in securely. Insert quick-connect wand into the spray gun, hand tighten until two parts are locked.

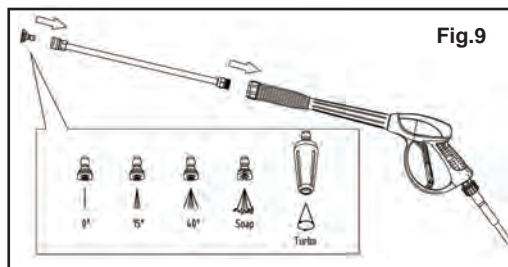

Storage position of turbo nozzle as shown in Fig.10

## Connect garden hose and inlet adapter

### As shown in Fig. 11

Attach a hose with a quick-connect coupling (not supplied) to water inlet on the high-pressure washer.

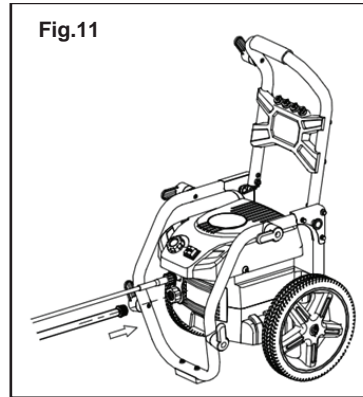
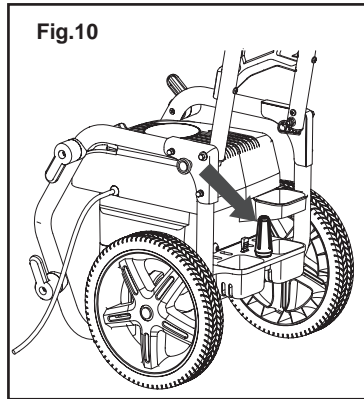

**Connect to water supply**  
**As shown in Fig. 12 & 13**

**⚠ WARNING!** Before carrying out actions below, make sure the ON/OFF switch is on the OFF position.

**⚠ WARNING!** The pressure washer may not be connected directly to the potable water supply. In this case, use an appropriate back-flow prevention device conforming to the requirements of the American Society of Sanitary Engineers.

1. Connect the water supply hose to water supply.
2. Open the water inlet valve.

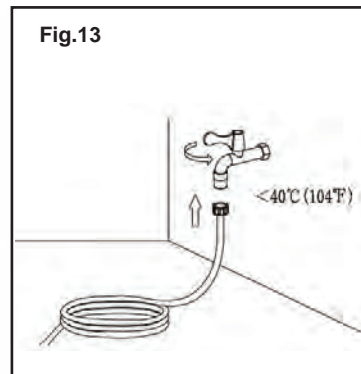
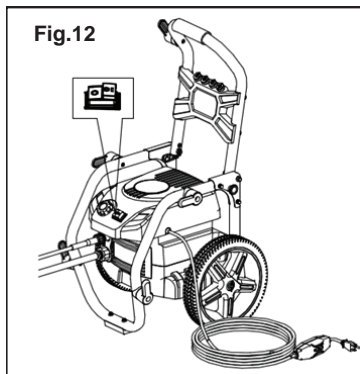

## KNOWLEDGE OF SPRAY TIPS

### As shown in Fig. 14

The spray tips are for purposes as below:

T1: Red-0°: Maximum cleaning pressure

T2: Yellow-15°: Delivers balanced pressure and flow for general cleaning

T3: White-40°: For delicate cleaning

T4: Black-Soap: Low pressure / to apply detergent

T5: Turbo: To remove particularly stubborn dirt

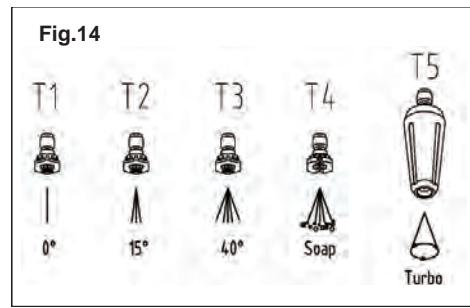

## ADJUSTMENT

### Adjusting the pressure

#### As shown in Fig. 15

This pressure washer is equipped with a pressure regulator. It has four settings. The approximate value for each setting is shown below:

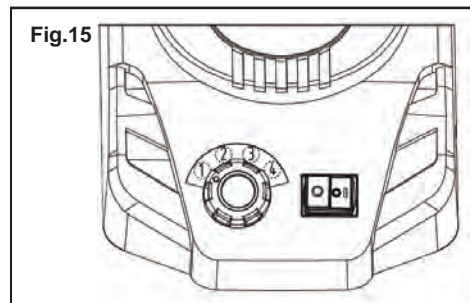

1. 1015psi;
2. 1305psi;
3. 1595psi;
4. 2200psi;

**To select the desired pressure**

Turn knob so the indicator mark aligns with the desired PSI setting.

**How to make use of the power cord/hose/gun holder**

**As shown in Fig. 16-1&16-2**

This pressure washer is equipped with 5 pieces of power cord/hose/gun holder. Each of them consists of three parts ( support and lever, central pin),each lever also could rotate 360 degree around its central pin clockwise or counter-clockwise, can stop in any required position.

**To rotate holder to specific position**

Simply put your hand on the holder/bracket and move to the required position.

Two holders/brackets on the same side of the washer can be used together to store the power cord/hose.

To tidy the power cord/hose quickly .

Rotate two holders so that raised lever can point outward at the same time. At this moment, it will prevent power cord/hose from slipping off.

To remove the power cord/hose quickly.

Rotate two holders so that the raised lever can point inward at the same time.

At this moment, it allows the user to remove the power cord/hose easily off the holder freely, which could save a lot of efforts.

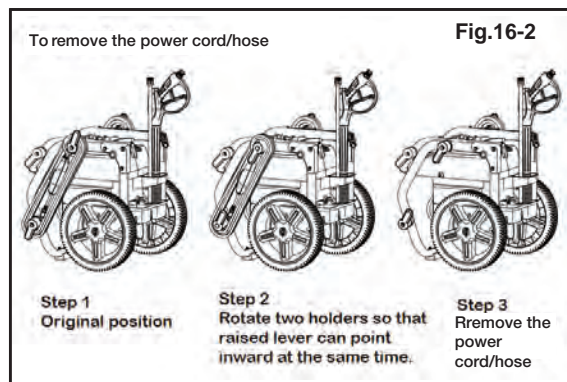
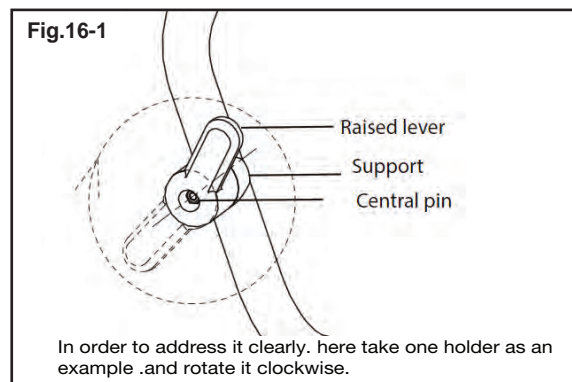



## OPERATING INSTRUCTIONS

**Connect to electrical main supply**  
As shown in Fig. 17

**⚠ DANGER!** Before you connect the pressure washer to the power source make sure that the data on the rating plate are identical to the mains data.

If possible, do not use extension cords with this pressure washer; however, if you must use one, it must comply with requirement mentioned in section of **“IMPORTANT SAFETY INSTRUCTIONS:**

Insert the power cord into the socket.

### Switch on/off

**CAUTION!** Put the high-pressure washer on a smooth ground. Stand in a secure and stable position.

**⚠ WARNING!** Before switching on, ensure you have completely assembled the high-pressure washer and connected all connections.

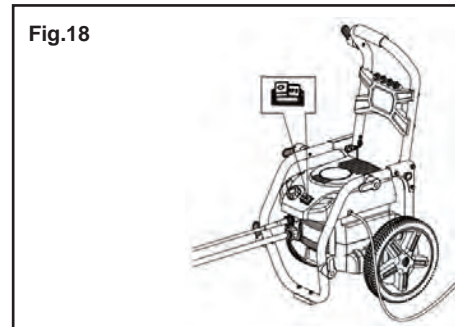
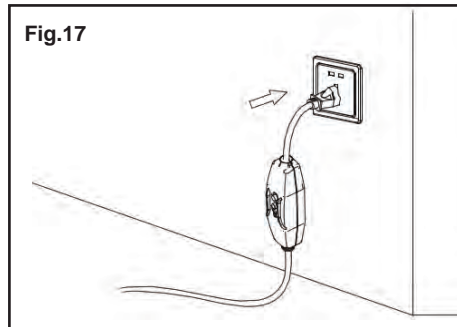

**To switch on**  
As shown in Fig. 18 & 19

You should maintain the correct operating position every time you start the pressure washer by placing one hand on the trigger handle handle and the other on the wand.

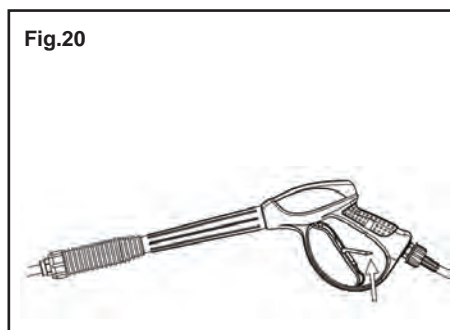
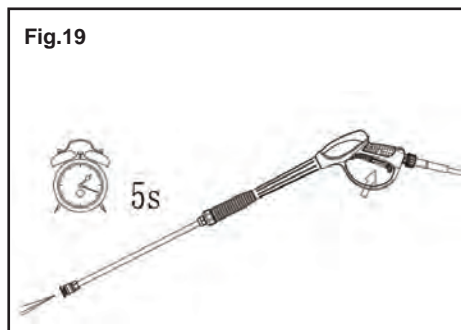

**⚠ CAUTION!** Before switching on, first purge pump by squeezing trigger handle for around 5 seconds.

To switch the pressure washer on, set the On/Off switch to ON.

1. Unlock the safety trigger lever on the spray gun, and press the trigger lever until there is a steady stream of water.

**⚠ CAUTION!** This pressure washer is equipped with **SOFT START FUNCTION**, which controlled by software. After switching on for 10 seconds, the motor will reach to the rated operating speed.

### To temporarily switch off

Release the trigger lever, at this point the equipment goes to standby. As soon as you press the trigger lever again, the equipment restarts.

### To completely switch off As shown in Fig. 20

1. Release the trigger lever, and replace the safety lock.
2. To switch the pressure washer off, set the On/Off switch to OFF.
3. Close the water inlet valve.

**⚠ CAUTION !** After releasing the trigger for 10 seconds, the motor can be completely stopped, due to this pressure washer is soft stop function which controlled by software.

**⚠ CAUTION ! Risk of pressure washer damage!**

Never operate the pressure washer without water inlet as dry running may damage the pump.

Use a water filter if the inlet water is contaminated.

**To temporarily store the spray gun**

**As shown in Fig. 21**

When fixing the handle to operating position, this pressure washer provides gun holder on right side. Which consist of three pieces power cord/hose/gun holder. It allows to temporarily rest the spray gun on it.

**Working with the electric high-pressure washer risk of fatal injury!**

Use special care when cleaning tires. Vehicle tires/tire valves may become damaged or burst when handled improperly. First signs of damage included discolorations on the tire.

Damaged vehicle tires/tire valves pose a life-threatening risk. Keep the jet at a distance of at least 12 inches!



**Risk of fatal injury!**

The high-pressure jet may be dangerous when handled improperly. The jet may not be directed towards living beings (persons, animals), live-equipment or the pressure washer itself.

**To operate trigger handle and wand**

Hold the handheld spray gun and the jet tube firmly with both hands. Be aware of the recoil when switching on the high-pressure jet.

Unlock the safety button and press the trigger on the handheld spray gun.

The high-pressure pump starts running as soon as you operate the hand-held spray gun. Due to the soft start function, after switching on for 10 seconds, the motor will reach to the rated operating speed.

After releasing the trigger for 10 seconds, the motor can be completely stopped, due to this pressure washer is soft stop function which controlled by software.

### **Use the detergent bottle (not supplied)**

**As shown in Fig. 22**

1. Stop the pressure washer.
2. Add detergent to the bottle (not supplied). Gently pull the detergent intake hose out, and put the end of detergent intake hose into the bottle. Make sure the end of the hose can reach the bottom of the detergent bottle.

**NOTE:** Put the detergent bottle nearby the pressure washer, there is no specific detergent bottle storage location on the pressure washer.

3. Insert soap nozzle, and turn the pressure regulator for the best results.
4. When you have finished using the detergent injection system, fill detergent bottle with clean water. Siphon water by using soap tip for one minute, so that all detergent is flushed through system. Remove detergent bottle, and rinse it thoroughly.

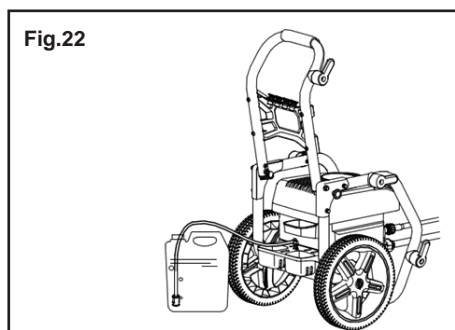

## CLEANING AND MAINTENANCE

### Clean the outside of high-pressure washer

Clean the pressure washer. Wipe the washer with a slightly damp cloth. Do not clean the pressure washer using a high-pressure water jet.

### Clean the water filter

#### As shown in Fig. 23

The pressure washer is equipped with a water filter to protect the pump. If the filter is not kept clean, the water flow to the pressure washer will be restricted and the pump may be damaged.

To clean water inlet filter,

1. remove the water inlet filter inside the inlet adaptor.
2. Rinse water inlet filter until it is free of debris and blockage.
3. Place water inlet filter back in position to prevent any foreign matter from entering the pump.

### Clean the spray nozzles

Clean the high-pressure spray nozzles.

#### As shown in Fig. 24

### Maintenance

The pressure washer has no user serviceable parts.

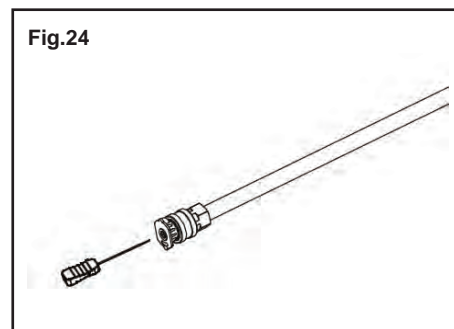
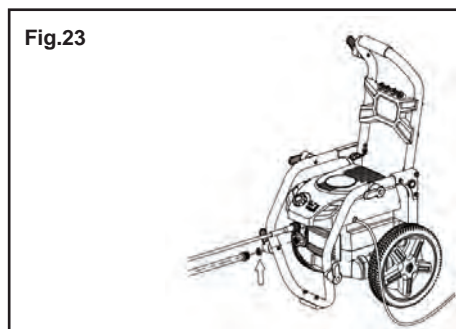

## MOVING AND STORAGE INSTRUCTIONS

### CAUTION!

Before servicing, cleaning, or removal of any part, switch off power and relieve pressure.

### STORAGE

As shown in Fig. 25 & 26

1. Remove the cleaning agent and drain all the water left in the hoses.
2. Clean the high-pressure washer.
3. Fold the handle.
4. Tidy the hose and power cord by winding them around the power cord/hose/gun holder, located on the metal support.

5. Store the pressure washer where it is dry and well ventilated, when placing the pressure washer out of service for short period of time.

6. To store the pressure washer for long period of time.

The storage method is the same as above mentioned. In addition, store the pressure washer by using the original package as much as you can.

### Moving

If shipping, use the original packaging whenever possible.

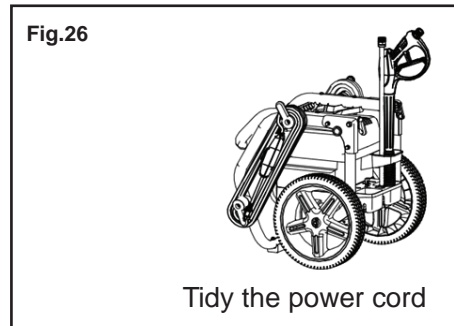
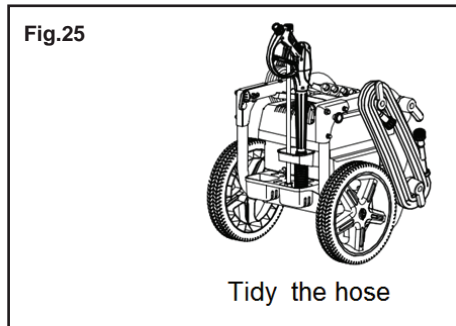

## DISPOSAL

### Disposing of the pressure washer

Pressure washers which are labeled with the adjacent symbol must not be disposed of in household garbage. You must dispose of such old electrical and electronic appliances separately. Please check with your local authority about the possibilities for correct disposal. Through separate disposal you send old equipment for recycling or for other forms of re-use. You will thus help to avoid in some cases that damaging material gets into the environment.

### Disposing of the packaging

The packaging consists of cardboard and correspondingly marked sheets that can be recycled. Make these materials available for recycling.

## TROUBLESHOOTING

### CAUTION!

Before servicing, cleaning, or removal of any part, switch off power and relieve pressure.

### CAUTION!

Improper repairs can result in the pressure washer functioning unsafely. This endangers yourself and your environment.

Faults which cannot be rectified with the aid of following table may be rectified by a specialist company only (customer service center).

Please be aware that any improper repairs will also invalidate the warranty and additional costs may be incurred.

Use only genuine spare parts. Only these spare parts are designed and suitable for the pressure washer. The use of other spare parts not only voids the warranty, but can also endanger yourself and your environment.

<b>Fault/malfunction</b>	<b>Cause</b>	<b>Remedy</b>
Pressure washers does not work	No electrical voltage at the device	Check the fuse, power cord, power plug and power source and have them replaced by qualified personnel if necessary
	On/off switch set to "0"	On/off switch set to "I"
	Cross section of the extension cord no large enough and/or the extension cord is too long	Use extension cord with lager cross sections and/or use shorter extension cords
	Extension cord damaged	try without extension cord
	The protector on the PCB has activated	Switch off the Pressure washer and pull the plug out from the power source, then restart the Pressure washer
	The mains voltage is lower than that specified	Contact the power supply company if necessary
	The pump is frozen	Check and thaw if necessary
Pressure too low, but steady	Wrong spray tips was selected	Change to right spray nozzles
	Hight-pressure hose are damaged or leaks in the connection	Change the high-pressure hose or hand-tighten the screw connection
Leaks in the Pressure washer	Leaks from the pump or internal connections	Consult customer service
	Hose connections loose	Hand-tighten the water intake adapter and the high-pressure hose screw connection
Irregular operating pressure	Air intake in the water inlet	Check the supply hose and hose connection and replace if necessary
	The water filter is clogged	Clean the water filter
	Water supply hoses squeezed	Straighten out kinked water supply hoses
	Inadequate water supply	Check the water supply
The high-pressure washer operates intermittently	Power cord is damaged	Consult customer service
	Internal loose electrical connection	Consult customer service
	On/Off switch defective	Consult customer service



The motor starts but there is no buildup of pressure	The water filter is clogged	Clean the water filter
	Air intake in the water inlet	Check the supply hose and hose connection and replace if necessary
	Air in the system	Ventilate the pressure washer! Run the pressure washer without the pressure washer hose connected until water starts leaking without bubbles. Re-attach the high-pressure hose.
	Spray tips partly blocked	Clean spray nozzles
No detergent taken in	Detergent too dense	Dilute with water
	Deposits or restriction in detergent circuit	Flush with clean water and eliminate any restrictions

# WARRANTY

## **Product Warranty**

Please keep your original purchase receipt in a safe place as proof of purchase. Warranty coverage for this product must be verified by the original purchase receipt. The warranty period begins on the day that the product was purchased from an authorized retailer of Yard Force products. Warranty coverage only applies to the original purchaser and is not transferrable. Warranty coverage is only provided on products purchased from authorized Yard Force retailers.

## **(2) Two-Year Warranty – Pump and Motor**

The YF2200BL has a 2-Year Limited Warranty from the date of purchase against manufacturer defects for residential use only. Commercial use voids the warranty. This warranty does not cover accidental damage, unreasonable use, normal wear and tear, neglect or non-compliance with the Operating, Safety and Maintenance Instructions. All service, outside of normal maintenance as described in this manual, must be done by an authorized service technician. Any unauthorized service or changes to the original configuration of this product will void the warranty. All parts and accessories used on and with this product must be manufacturer/or and authorized by SUMEC North America.

## **(90) Ninety-Day Warranty – Accessories**

The accessories included with the YF2200BL; including hose, trigger handle and wand, and other similar parts are warranted against manufacturer defects for residential use only for a period of 90 days from date of purchase.

Warranty does not cover loss of use or other consequential damages arising from any of the above, nor does it cover repairs made or attempted by unauthorized persons. This warranty is void if the product is used for commercial, rental or industrial purposes. Certain parts, attachments and accessories are subject to normal wear and tear and are excluded from the warranty.

## **Service and Warranty Claims Process**

Contact the Yard Force Support Center toll-free at (866) 902-9690 Monday-Friday between 8:30 AM and 5:00 PM Eastern Time for service and warranty support.

Yard Force USA Service Support agents can help you troubleshoot problems over the phone to get you back up and running as quickly as possible. In the situation where service or warranty inspection is needed, please follow these steps:

1. Contact Yard Force USA at (866) 902-9690 Monday-Friday between 8:30 AM and 5:00 PM Eastern Time.
2. Send in proof-of-purchase and serial number (if applicable) to confirm warranty coverage.
3. If service or a warranty evaluation is requested, Yard Force USA will provide an RGA number that should be used in all communications with Yard Force USA and is required to be indicated on the product itself and on the outside of the box.
4. All shipments to Yard Force USA must have an RGA number. Any shipment received that does not have an RGA number clearly marked on the outside of the box will be refused.
5. All shipments must be sent pre-paid, Yard Force USA does not pay for any shipping costs for service or warranty evaluation. Yard Force USA is not responsible for any packages that are lost by carrier. We recommend that shipments are made by a carrier that provides tracking and delivery confirmation.

For more information or to ask questions, please call toll-free (866) 902-9690 Monday-Friday between 8:30 AM and 5:00 PM Eastern Time.

**SAVE THESE INSTRUCTIONS**